

UltraSIL polymer-housed Evolution (10 kA) IEEE surge arresters for MV systems to 36 kV



General

Eaton set the standard for design, manufacturing, and delivery of polymeric distribution arresters with its Cooper Power™ series UltraSIL™ polymer-housed arrester family. The UltraSIL polymer-housed Evolution™ surge arrester from Eaton's Cooper Power series product-line incorporates the industry recognized superior polymer-housing material—silicone rubber.

The Evolution surge arrester uses specially formulated and highly durable metal oxide varistors (MOVs) in combination with a proprietary insulating ceramic ring assembly. The mating of these two proven technologies allows Eaton to offer a distribution class arrester with riser-pole protective characteristics and infinite TOV capability. The Evolution surge arrester offers significant improvements in protective characteristics and 60 Hz temporary overvoltage (TOV) capability for all common over-head and riser-pole applications.

Construction

The patented construction of the Evolution surge arrester comprises the arrester module assembly encapsulated in a high-strength composite matrix insulating material. The components of the arrester module assembly consist of MOVs in series with a proprietary insulating ceramic ring assembly. The insulating ceramic ring assembly withstands system voltage during steady-state conditions and reduces electrical stress across the MOV disks.

The components of the arrester module assembly are encapsulated on Eaton's fully automated assembly line using strict quality control processes. The composite matrix is cured to the arrester module assembly to form a solid insulation system, which is then inserted and bonded to the industry-leading track-resistant UltraSIL polymer-housing material.

The composite-bonded module assembly provides a secondary moisture seal underneath the primary seal of the UltraSIL polymer-housing material. The combinations of these technologies allow the Evolution surge arrester to be impervious to moisture and capable of withstanding extreme electrical, environmental and cantilever load conditions. The composite-wrapped module assembly used in the Evolution surge arrester represents a quantum leap in polymer arrester technology.

Following assembly, each arrester is subjected to a battery of electrical tests to ensure the highest quality and in-service field performance.

EATON

Powering Business Worldwide

Features

The Evolution surge arrester exceeds protective levels offered by standard MOV arresters and helps compensate for two variables related to installation practices and equipment protection:

- Excessive lead length
- Aged equipment insulation

UltraSIL polymer-housing material has undergone a wide range of design tests to determine the optimum shed configuration. In addition, long-term environmental testing has verified the lifetime superiority of silicone rubber when compared to other polymeric insulating materials.

Independent laboratory tests have verified the superiority of polymer-housing material in terms of non-wetting surfaces, resistance to UV degradation and surface tracking, performance in contaminated environments, chemical inertness, temperature stability, and other important insulating properties. UltraSIL polymer-housing material will not support biological growth (algae and mildew), is non-flammable, and will not support combustion.

An optional insulated mounting hanger is available to allow connecting to a wide variety of brackets. The insulated hanger, made of glass-filled polyester, has been designed to provide needed mechanical strength for installation and severe loading conditions.

A ground lead isolator is also available. The isolator removes the ground terminal from the arrester in the unlikely event of arrester failure, thus preventing a permanent system fault. An isolator that has operated gives visual indication of internal damage to the arrester and the need for arrester replacement. See **Figure 2** for the isolator operating characteristics.

An optional universal wildlife protector has two self-adjusting "valve" style openings that vary from 0 to 0.75 inches in diameter, thus allowing for a large variety of conductor/insulation sizes while providing optimum wildlife protection. (See **page 12**, **Figure 9** for a dimensional diagram.)

Customers looking to improve system reliability by minimizing wildlife-related outages now have multiple options. In addition to the universal wildlife protector, Eaton also offers the more robust line terminal wildlife guard. The line terminal wildlife guard is easily retrofitted to existing arrester installations and provides increased electrical insulation for the high-voltage terminal of the arrester. The flexible design of the line terminal wildlife guard allows insertion of the lead wire through the bottom of the integral molded flanges. The access holes molded above the flanges will allow conductor sizes ranging from 0 to 0.50 inches in diameter (OD). The line terminal wildlife guard's geometry allows water to shed away from the surface area of the wildlife guard while minimizing ice buildup and maintaining flexibility through extreme operating temperatures. See **Figure 9** for a dimensional diagram.

For complete wildlife resistance, the ground terminal wildlife guard can easily be installed alongside the line terminal wildlife guard or universal wildlife protector. The ground terminal wildlife guard is a compact and economical guard that ensures wildlife is unable to come in contact with energized objects while on a grounded surface. See **Figure 10** for a dimensional diagram.

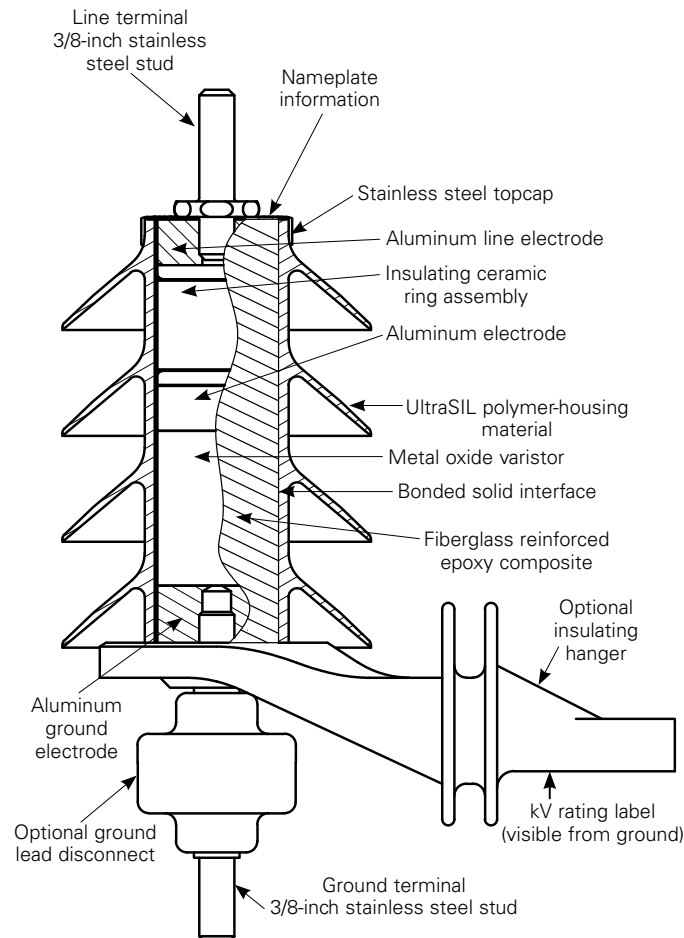

Figure 1. Cutaway illustration of the Evolution distribution surge arrester

Operation

The operation of Evolution surge arresters differs from conventional metal oxide arresters. During steady-state conditions, the insulating ceramic ring assembly withstands system voltage while reducing electrical stress on the MOV disks. When surges occur, the insulating ceramic ring assembly sparks over, leaving only the MOV disks in the circuit. The result is much lower discharge voltages as compared to standard heavy duty and riser pole metal oxide arresters. The added insulating ceramic ring assembly extends TOV capability for levels up to 1.78 P/U forever. Improving the Evolution surge arrester's resistance to overvoltage conditions reduces system maintenance related to arresters and helps improve system reliability.

Design testing

The housing material, internals, and hardware work together as a system and must stand up to years of exposure to environmental extremes. To ensure a superior level of performance, both the components and assembled arrester units have been subjected to a program of testing that accurately simulates years of exposure to actual field conditions. Testing includes:

IEEE® Std C62.11™ testing—Full certification to performance requirements by an independent laboratory. Reference *CP0804, UltraSIL Polymer-Housed Evolution Surge Arrester Certified Test Report* for details. Additional reference documents are listed on **page 14**.

To demonstrate the resistance of a composite-wrapped module to moisture ingress, Eaton performed the Water Immersion Test on the Evolution surge arrester without the polymer-housing material. This test was completed in accordance with IEEE Std C62.11-2005, Section 8.22, and IEC 60099-4, Ed 2 2004. The arrester sample passed the test by demonstrating less than 5% change in residual voltage, less than 20% change in power loss, less than 10pC of internal partial discharge with no signs of physical damage. A test report is available upon request.

Production tests

A complete production test program ensures a quality product. Each MOV receives a series of electrical tests. Quality is demonstrated by a series of destructive tests performed on every batch of varistors. Listed are the production tests performed on the varistors:

- 100% physical inspection
- 100% discharge voltage test
- 100% V1mA/cm²
- 100% leakage current at 80% of V1mA/cm² voltage
- Batch high-current, short-duration test
- Batch thermal stability test
- Batch aging test

Each fully assembled arrester must pass the following production tests:

- 100% physical inspection
- 100% partial discharge inception voltage test
- 100% 60 Hz sparkover level test

Table 1. Commonly applied voltage ratings of Evolution surge arresters

System voltage (kV rms)		Recommended arrester rating per IEEE Std C62.22 (kV rms)					
		Four-wire wye multi-grounded neutral		Three-wire wye solidly grounded neutral		Delta and ungrounded wye	
Nominal	Maximum	Standard MOV arrester	URT	Standard MOV arrester	URT ①	Standard MOV arrester	URT ①
2.4	2.54	—	—	—	—	3	3
4.16Y/2.4	4.4Y/2.54	3	3	6	—	6	6
4.16	4.4	—	—	—	—	6	6
4.8	5.08	—	—	—	—	6	6
6.9	7.26	—	—	—	—	9	6
8.32Y/4.8	8.8Y/5.08	6	6	9	9	—	—
12.0Y/6.9	12.7Y/7.33	9	9	12	12	—	—
12.47Y/7.2	13.2Y/7.62	9	9	15	15	—	—
13.2Y/7.62	13.97Y/8.07	10	10	15	15	—	—
13.8Y/7.97	14.52Y/8.38	—	—	15	15	—	—
13.8	14.52	—	—	—	—	18	15
20.78Y/12.0	22.0Y/12.7	15	15	21	21	—	—
22.86Y/13.2	24.2Y/13.97	18	18	24	24	—	—
23	24.34	—	—	—	—	30	27
24.94Y/14.4	26.4Y/15.24	18	18	27	27	—	—
27.6Y/15.935	29.255Y/16.89	21	21	30	30	—	—
34.5Y/19.92	36.5Y/21.08	27	27	36	36	—	36
46Y/26.6	48.3Y/28.0	36	36	—	—	—	—

① Recommended arrester ratings for the Evolution arrester for three-wire solidly grounded neutral, delta, and ungrounded wye circuits are based upon 5% regulation error.

General application recommendations

The rating of an arrester is the maximum power frequency line-to-ground voltage at which the arrester is designed to pass an operating duty-cycle test. **Table 1** provides a general application guide for the selection of the proper arrester rating for a given system voltage and system grounding configuration as outlined in the IEEE Std C62.22™ application guide.

Under fault conditions and other system anomalies, higher voltages can be experienced by the arrester. To ensure that the arrester ratings will not be exceeded, Eaton application engineers are available to make recommendations. The following information is normally required:

1. System maximum operating voltage.
2. System grounding conditions.
 - A. For four-wire circuits, grounding conditions depend upon whether the system is multi-grounded, whether it has a neutral impedance and whether common primary and secondary neutrals are used.
 - B. For three-wire circuits, grounding conditions depend upon whether the system is solidly grounded at the source, grounded through neutral impedance at the source transformers, or ungrounded.

Consult your Eaton representative to have your individual system application needs studied.

Performance test characteristics

Evolution distribution class surge arresters withstand the following design tests as described by IEEE Std C62.11.

- **Duty cycle:**
22 current surges of 10 kA crest, 8/20 μs waveshape
- **High-current, short-duration discharge:**
2 current surges of 100 kA crest, 4/10 μs waveshape
- **Low-current, long-duration discharge:**
20 current surges of 250 A crest 2000 μs duration rectangular wave

Following each of these tests, the arresters remain thermally stable as verified by:

- Continually decreasing power values during a 30-minute power monitoring period
- No evidence of physical or electrical deterioration
- The 10 kA discharge voltages measured after each test changed less than 10% from the initial values

In addition, **full IEEE Std C62.11 certification has been completed and verified.**

Fault current withstand tests

Fault current withstand tests demonstrate the ability to withstand fault currents for specific durations without expelling any internal components. All Evolution distribution class surge arrester designs have been tested in accordance with the requirements listed in IEEE Std C62.11, and are non-fragmenting to the levels shown in **Table 2**.

Table 2. Fault current withstand tests

Fault current amplitude (kA rms)	Fault current duration (cycles)
0.6	60
20.0	12

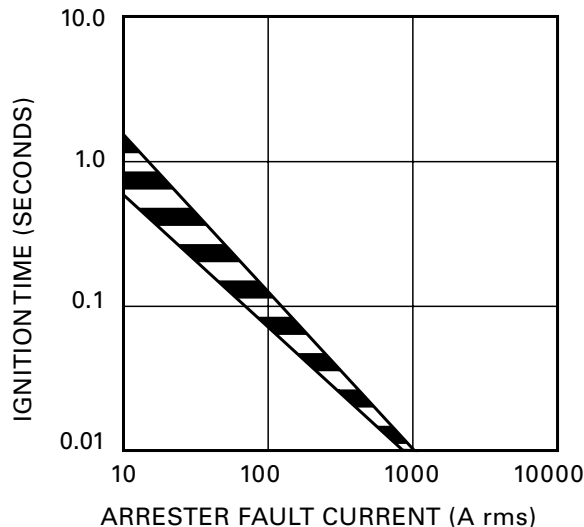

Figure 2. Isolator operating characteristic

Table 3. Insulation withstand characteristics of optional insulated mounting bracket

Insulated mounting bracket	Bracket mounting length center-to-center (inches)	Leakage distance (inches)	Strike (inches)	Power frequency voltage withstand (60 sec, wet, kV)	1.2/50 μ s impulse (kV crest)
Standard for rating 3–10 kV	4.10	5.90	2.80	36	70
Standard for rating 12–36 kV	5.00	8.90	3.90	48	80

Dimensions and clearances

Outline drawings for several common design options are shown in **Figure 3–Figure 6**. Dimensions for these designs are listed in **Table 4**.

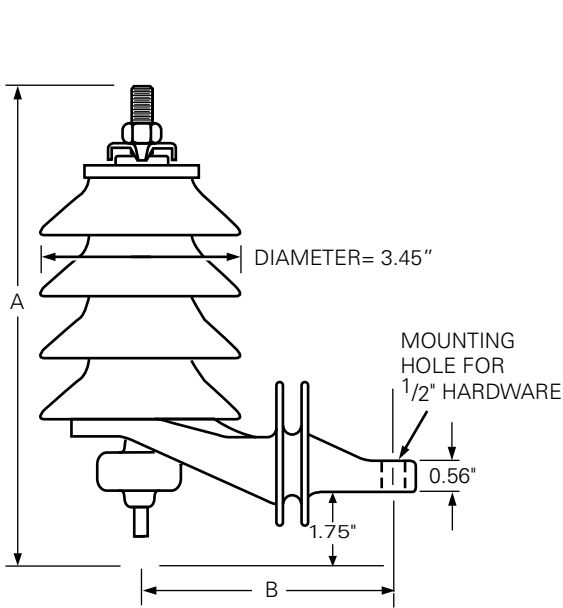

Figure 3. Evolution surge arrester with isolator and insulated hanger

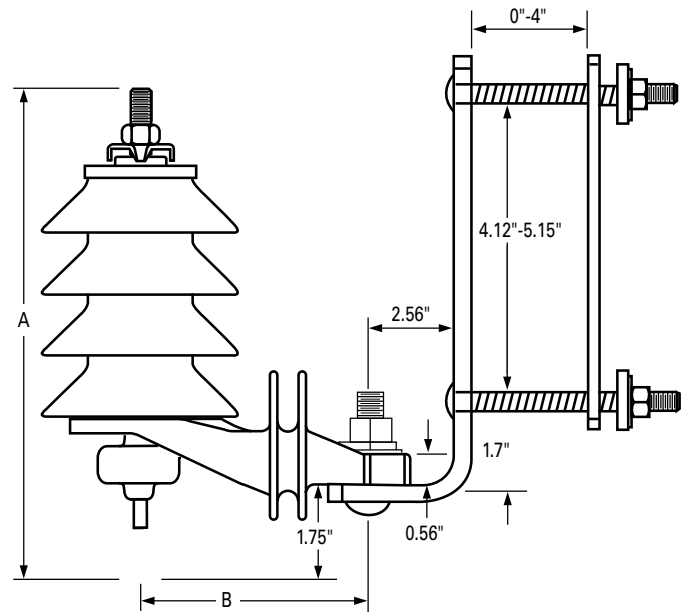

Figure 4. Evolution surge arrester with isolator, insulated hanger and NEMA® cross-arm bracket

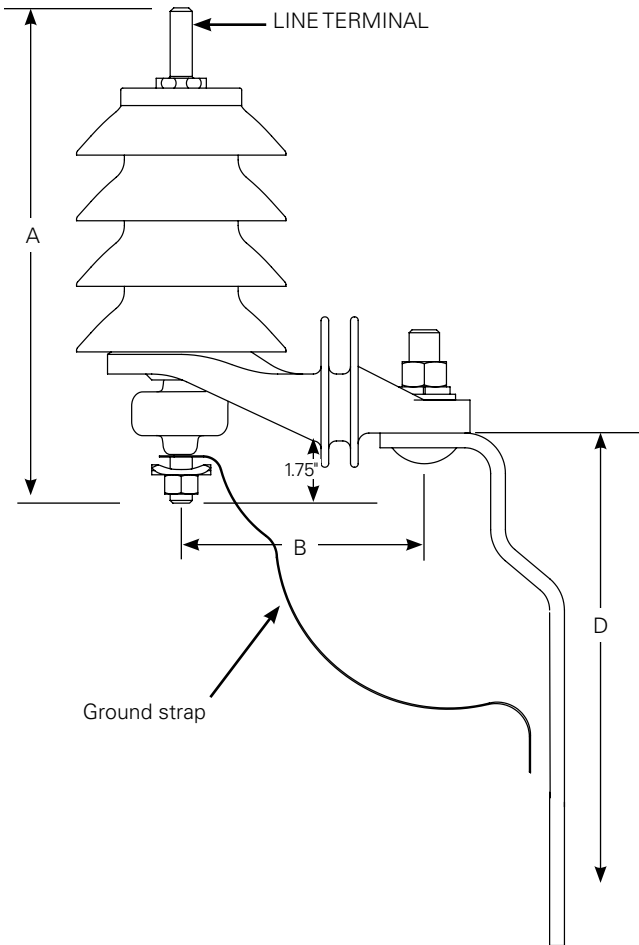

Figure 5. Evolution surge arrester with isolator, insulated hanger, and transformer mounting bracket

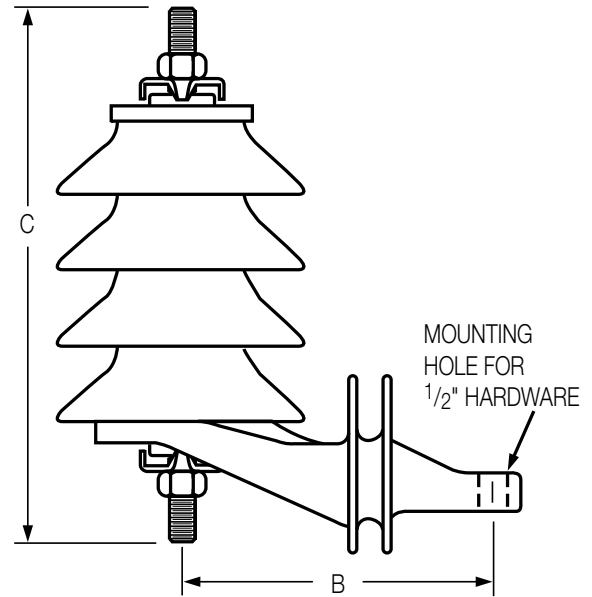

Figure 6. Evolution surge arrester without isolator including insulated hanger and NEMA cross-arm bracket

Table 4. Dimensional data—Evolution surge arresters

Arrester rating (kV rms)	Standard housing code (Digits 6 and 7, Table 8)	Dimensions Figures 3–6 (inches)				Minimum recommended clearances (inches) ①	
		A ②	B	C ②	D	Heavy duty	
						Phase-to-ground	Phase-to-phase
3	04	7.9	4.1	6.5	8.7	3.00	4.25
6	05	9.0	4.1	7.6	8.7	4.00	5.50
9	05	9.0	4.1	7.6	8.7	5.25	7.00
10	05	9.0	4.1	7.6	8.7	5.25	7.00
12	07	11.1	5.0	9.7	8.7	6.00	7.75
15	07	11.1	5.0	9.7	8.7	6.75	8.75
18	08	12.2	5.0	10.8	8.7	9.25	11.25
21	09	13.2	5.0	11.8	8.7	9.25	11.25
24	10	14.3	5.0	12.9	8.7	10.75	13.25
27	11	15.3	5.0	13.9	14.3	10.75	13.25
30	12	16.4	5.0	15.0	14.3	10.75	13.25
33	13	17.5	5.0	16.1	14.3	12.75	16.25
36	14	18.5	5.0	17.1	14.3	12.75	16.25

① All clearances are measured from center line of arrester per IEEE Std C62.22.

② With optional wildlife protector, add 0.2 inches.

Insulation characteristics

The insulation characteristics of the Evolution surge arrester family are shown in **Table 5**.

Table 5. Housing insulation withstand voltages of evolution surge arresters

Arrester housing code (Digits 6 & 7)	Creep distance (in.)	Strike (in.)	4.1" mounting			5.0" mounting			4.1" mounting			5.0" mounting			5.0" mounting		
			1.2/50 μ s impulse (kV crest)	1 min. dry (kV rms)	10 sec. wet (kV rms)	1.2/50 μ s impulse (kV crest)	1 min. dry (kV rms)	10 sec. wet (kV rms)	1.2/50 μ s impulse (kV crest)	1 min. dry (kV rms)	10 sec. wet (kV rms)	1.2/50 μ s impulse (kV crest)	1 min. dry (kV rms)	10 sec. wet (kV rms)	1.2/50 μ s impulse (kV crest)	1 min. dry (kV rms)	10 sec. wet (kV rms)
04	10.1	4.2	91	56	36	105	55	39	79	52	34	99	56	39	82	51	33
05	13.0	5.2	104	64	45	117	63	52	89	55	44	109	60	52	90	62	46
06	15.9	6.3	117	78	57	126	86	59	93	61	58	119	80	59	97	72	56
07	18.8	7.3	129	87	68	137	96	71	98	62	59	122	81	63	107	81	69
08	21.7	8.4	140	96	79	148	106	83	104	65	61	126	82	67	118	89	81
09	24.6	9.4	152	105	89	159	116	94	110	68	63	130	83	72	129	98	93
10	27.5	10.5	164	114	100	171	126	105	117	72	67	136	86	78	140	106	105
11	30.4	11.5	176	123	110	183	135	116	125	77	71	142	90	83	152	114	116
12	33.3	12.6	189	131	120	195	144	127	133	82	75	149	94	89	164	122	126
13	36.2	13.6	201	139	130	207	153	137	142	88	81	158	99	96	177	130	136
14	39.1	14.7	215	148	140	220	161	147	152	94	87	167	105	102	190	138	145
15	42.0	15.8	228	155	150	233	170	157	162	101	93	177	112	109	204	146	153
16	44.9	16.8	242	183	158	246	178	167	173	109	101	187	120	117	218	154	162
17	47.8	17.8	255	171	169	259	185	176	185	117	109	199	128	125	233	161	169

Protective characteristics

Evolution distribution class surge arresters provide excellent overvoltage protection for electrical equipment throughout distribution systems. The protective characteristics of the Evolution surge arrester are shown in **Table 6**.

Table 6. Protective characteristics—Evolution surge arrester heavy duty (URT)

Arrester rating (kV rms)	MCOV (kV rms)	Minimum 60 Hz sparkover (kV crest/ $\sqrt{2}$)	Front-of-wave protective level ① (kV crest)	Third-party front-of-wave protective level ② (kV crest)	Maximum discharge voltage (kV crest) 8/20 μ s current wave						Switching surge (kV crest)
					1.5 kA	3 kA	5 kA	10 kA	20 kA	40 kA	
3	2.55	4.54	20.0	—	8.1	8.7	9.3	10.2	11.6	13.5	7.6
6	5.10	9.08	23.0	—	16.1	17.4	18.6	20.3	23.3	27.0	15.2
9	7.65	13.6	32.4	—	18.9	20.3	21.8	23.8	27.3	31.6	17.8
10	8.40	15.0	32.4	24.3	20.1	21.6	23.2	25.4	29.0	33.7	19.0
12	10.2	18.2	52.4	—	25.2	27.2	29.1	31.8	36.4	42.2	23.8
15	12.7	22.6	55.4	—	30.5	32.8	35.2	38.5	44.0	51.1	28.8
18	15.3	27.2	64.8	51.1	37.8	40.8	43.7	47.8	54.6	63.4	35.7
21	17.0	30.3	64.8	—	40.1	43.2	46.3	50.6	57.9	67.2	37.8
24	19.5	34.7	87.8	—	46.4	50.0	53.6	58.6	67.0	78	43.8
27	22.0	39.2	97.2	66.9	53.9	58.0	62.2	68.0	78	90	50.8
30	24.4	43.4	117.2	—	58.6	63.2	67.7	74	85	98	55.3
33	27.0	48.1	120.2	—	66.6	71.7	77	84	96	112	62.8
36	29.0	51.6	129.6	—	70.4	76	81	89	102	118	66.4

① The Front-of-Wave Protective Level is the larger of the Front-of-Wave Sparkover Voltage (FOW) or Equivalent Front-of-Wave Discharge Voltage (EFOW) per IEEE Std. C62.11-2005. The Front-of-Wave Sparkover Level is based on a voltage waveform having a rate of rise of 100 kV/ μ s for each 12 kV of arrester duty cycle rating. The EFOW is a discharge voltage resulting from a 10 kA current impulse cresting in 0.5 μ s. The Front-of-Wave Protective Level for the Evolution arrester is the FOW Sparkover Level.

② The third-party test report CP1012 is available on www.eaton.com/cooperpowerseries website and includes test data for standard production 10 kV, 18 kV, and 27 kV arresters.

Ordering information

Evolution surge arresters can be ordered in a variety of customer defined options. **Table 7** below lists standard part numbers for our most common design options (see illustrations on **page 5–page 6, Figure 3–Figure 6**). For other design options, use Table 8 to customize the arrester to specific needs. For further options, contact your Eaton sales engineer.

Temporary overvoltage (TOV) capability

The ability to withstand 60 Hz overvoltage conditions [temporary overvoltage (TOV)] is shown in **Figure 7** for all Evolution distribution-class surge arresters. The graph shows for a given voltage magnitude (on a per unit of MCOV basis) the time an arrester can survive a TOV condition without going into thermal runaway.

UltraSIL Housed EVOLUTION Arrester
TOV Curve Per ANSI C62.11

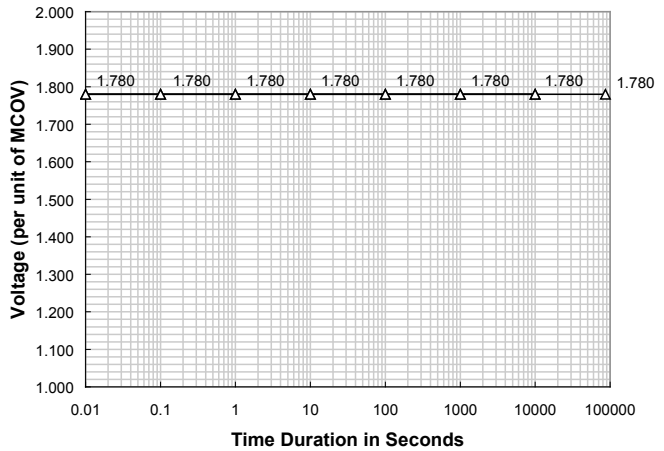

Figure 7. Temporary overvoltage curve, no prior duty—
60 °C ambient

Table 7. Catalog numbers—Evolution distribution class surge arresters

Arrester rating (kV rms)	With isolator and insulated hanger (Figure 3)	With isolator, insulated hanger and NEMA cross-arm bracket (Figure 4)	With isolator, insulated hanger and transformer mounting bracket (Figure 5)	With insulating hanger without isolator (Figure 6)
3	URT03040A1A1A1A	URT03040A1A1B1A	URT03040A1C1C1A	URT03040A0A1A1A
6	URT06050A1A1A1A	URT06050A1A1B1A	URT06050A1C1C1A	URT06050A0A1A1A
9	URT09050A1A1A1A	URT09050A1A1B1A	URT09050A1C1C1A	URT09050A0A1A1A
10	URT10050A1A1A1A	URT10050A1A1B1A	URT10050A1C1C1A	URT10050A0A1A1A
12	URT12070A1A1A1A	URT12070A1A1B1A	URT12070A1C1C1A	URT12070A0A1A1A
15	URT15070A1A1A1A	URT15070A1A1B1A	URT15070A1C1C1A	URT15070A0A1A1A
18	URT18080A1A1A1A	URT18080A1A1B1A	URT18080A1C1C1A	URT18080A0A1A1A
21	URT21090A1A1A1A	URT21090A1A1B1A	URT21090A1C1C1A	URT21090A0A1A1A
24	URT24100A1A1A1A	URT24100A1A1B1A	URT24100A1C1C1A	URT24100A0A1A1A
27	URT27110A1A1A1A	URT27110A1A1B1A	URT27110A1C1C1A	URT27110A0A1A1A
30	URT30120A1A1A1A	URT30120A1A1B1A	URT30120A1C1C1A	URT30120A0A1A1A
33	URT33130A1A1A1A	URT33130A1A1B1A	URT33130A1C1C1A	URT33130A0A1A1A
36	URT36140A1A1A1A	URT36140A1A1B1A	URT36140A1C1C1A	URT36140A0A1A1A

Note: Digits 2 and 3 Options “RT” replaces Normal-Duty, Heavy-Duty, and Riser-Pole.

Note: All catalog numbers listed above include a universal wildlife protector; catalog number **AV346X1**.

Table 8. UltraSIL polymer-housed Evolution distribution-class surge arrester UltraQUIK™ catalog numbering system

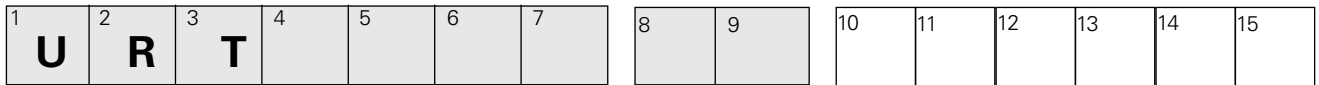

Catalog number digits:

1 = UltraSIL polymer-housed arrester: **U**

2 and 3 = Arrester class: **RT** = Evolution

4 and 5 = Arrester rating (MCOV):

03 = 3 kV (2.55 kV)	12 = 12 kV (10.2 kV)	21 = 21 kV (17.0 kV)	30 = 30 kV (24.4 kV)
06 = 6 kV (5.1 kV)	15 = 15 kV (12.7 kV)	24 = 24 kV (19.5 kV)	33 = 33 kV (27.0 kV)
09 = 9 kV (7.65 kV)	18 = 18 kV (15.3 kV)	27 = 27 kV (22.0 kV)	36 = 36 kV (29.0 kV)
10 = 10 kV (8.4 kV)			

6 and 7 = Housing code per arrester rating: select from table below.

★ = Standard creepage housing O = Optional creepage housings

Digits 6 and 7	04	05	06	07	08	09	10	11	12	13	14	15
Leakage distance (inches)	10.1	13.0	15.9	18.8	21.7	24.6	27.5	30.4	33.3	36.2	39.1	42.0
Arrester rating (kV rms)												
3	★											
6		★	O									
9		★	O	O	O							
10		★	O	O	O							
12				★	O	O	O					
15				★	O	O	O	O				
18					★	O	O	O				
21						★	O	O	O			
24							★	O	O	O	O	
27								★	O	O	O	O
30									★	O	O	O
33										★	O	O
36											★	O

8 = Line terminal wire: **0** = No line terminal wire

2 = 12", #6 AWG insulated wire, 1 ring terminal/1 end stripped 1.25"

5 = 18", #6 AWG insulated wire, 1 ring terminal/1 end stripped 1.25"

8 = 30", #6 AWG insulated wire, 1 ring terminal/1 end stripped 1.25"

3 = 12", #6 AWG insulated wire, 2 ring terminals

6 = 18", #6 AWG insulated wire, 2 ring terminals

9 = 30", #6 AWG insulated wire, 2 ring terminals

9 = Line terminal options

				
<p>A = Silicone bronze nut, stainless steel wire clamp and universal wildlife protector. Reference Figure 8 for dimensional information.</p>	<p>B = Silicone bronze nut and stainless steel wire clamp</p>	<p>C = No hardware</p>	<p>D = Silicone bronze nut, lock washer, flat washer and universal wildlife protector (for leads with ring terminals). Reference Figure 8 for dimensional information.</p>	<p>X = Silicone bronze nut, stainless steel wire clamp and line terminal wildlife guard. Reference Figure 9 for dimensional information.</p>

Table 8. UltraSIL polymer-housed Evolution distribution-class surge arrester UltraQUIK catalog numbering system (continued)

1	2	3	4	5	6	7	8	9	10	11	12	13	14	15
U	R	T												

10 = Isolator, with 3/8" stainless steel grounding stud

0 = No isolator

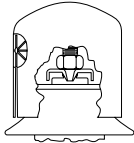
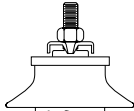
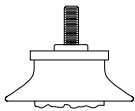
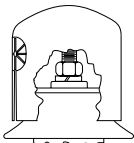
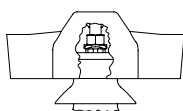
2 = Red isolator

4 = Blue isolator

6 = Orange isolator

1 = Black isolator (**standard**)

3 = Yellow isolator

5 = White isolator

11 = Ground terminal options

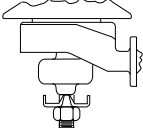
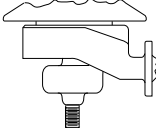
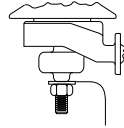
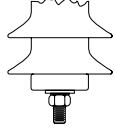
			
A = Stainless steel wire clamp with silicone bronze nut (shown with optional isolator and insulated hanger)	B = No hardware (shown with optional isolator and insulated hanger)	C = Copper transformer grounding strap with stainless steel lock washer and silicone bronze nut (shown with optional isolator and insulated hanger)	D = Stainless steel washer, lock washer, silicone bronze nut

12 = Base configuration options

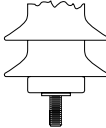
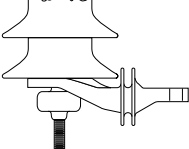
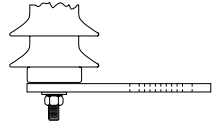
		
0 = Insulated base (base mounted arrester)	1 = Insulated hanger (required with optional isolator) (Available only if Digits 6 and 7 are housing options 15 or less ①) ① For more information, contact your Eaton representative.	2 = Insulated base with conductive mounting bracket (Requires "0" in Digit 10 and "D" in Digit 11)

13 = Mounting bracket options

			
A = Without an additional mounting bracket	B = NEMA cross-arm bracket (arrester mounting hardware included) (Requires "1" or "2" in Digit 12) (Refer to Figure 11 for dimensional information.)	C = Transformer bracket (arrester mounting hardware included) (Requires "1" or "2" in Digit 12) (Refer to Figure 12 and Figure 13 for dimensions by rating.)	D = Option C plus transformer mounting hardware (2 each – 1/2", 13-UNC x 3/4" bolts, flat washers, and lock washers) (Requires "1" or "2" in Digit 12) (Refer to Figure 12 and Figure 13 for dimensions by rating.)

Table 8. UltraSIL polymer-housed Evolution distribution-class surge arrester UltraQUIK catalog numbering system (continued)

1	2	3	4	5	6	7	8	9	10	11	12	13	14	15
U	R	T												

12 and 13 = Double Digit Mounting Options With Ground Terminal Wildlife Guard

 <p>E8 = Ground terminal wildlife guard, insulated hanger (shown with optional isolator), NEMA cross-arm bracket (arrester mounting hardware included) Refer to Figure 10 and Figure 11 for dimensional information.</p>	 <p>E9 = Ground terminal wildlife guard, insulated hanger (shown with optional isolator), transformer bracket. Reference Figure 10, Figure 12, and Figure 13 for dimensional information.</p>
---	---

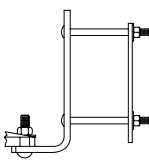
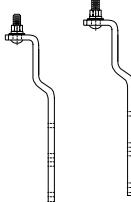
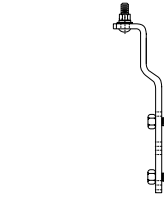
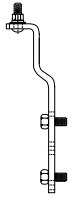
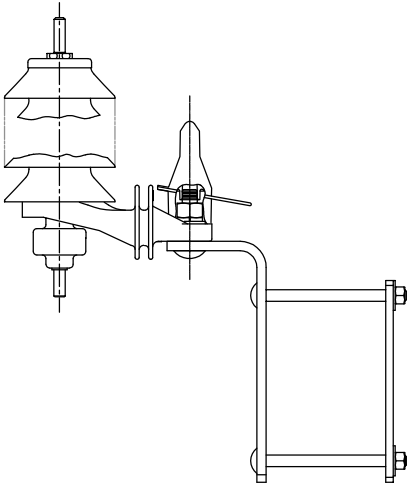
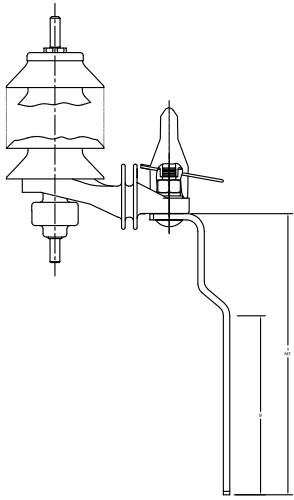
14 = Nameplate information: **1** = IEEE Std C62.11 required data

15 = Packaging:

- A** = Individual carton (assembled terminal hardware). Each arrester is shipped in an individual high-strength cardboard carton. The top and bottom terminal hardware is assembled to the arrester. Any optional brackets or hardware are provided unassembled.
- C** = Bulk packed (assembled terminal hardware). Pallet sized bulk cardboard packaging for transformer mounting bracket options (Digits 13 = C or D only). Each arrester is shipped fully assembled including transformer mounting bracket. Available for 3–24 kV arresters only. Full pallet quantities only: 3–10 kV = 90, 12–24 kV = 72.
- 3** = **International**, individual carton (assembled terminal hardware). Each arrester with accessories is shipped in an individual cardboard carton. The top and bottom terminal hardware is assembled to the arrester. Individual cartons are packed within a heavy-duty quadwall carton having a skid bottom and suitable for double stacking within an ocean shipping container.

Available accessories for the Evolution surge arrester

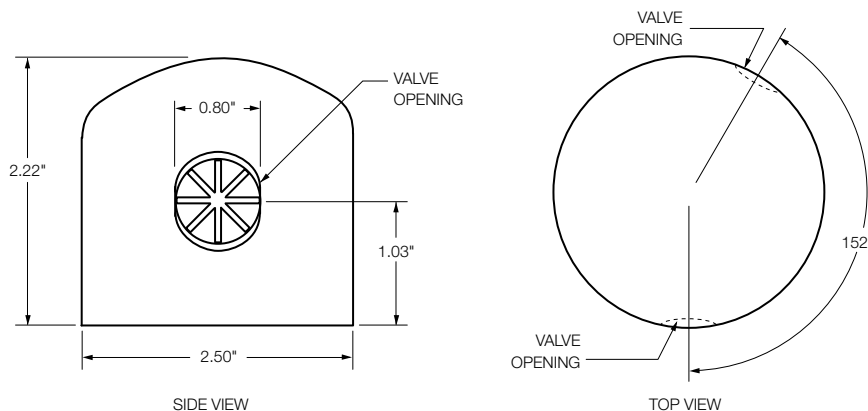

Figure 8. Universal wildlife protector (catalog number AV346X1C)

The optional universal wildlife protector has two self-adjusting “valve” style openings that vary from 0 to 0.75 inches in diameter, thus allowing for a large variety of conductor/insulation sizes while providing optimum wildlife protection.

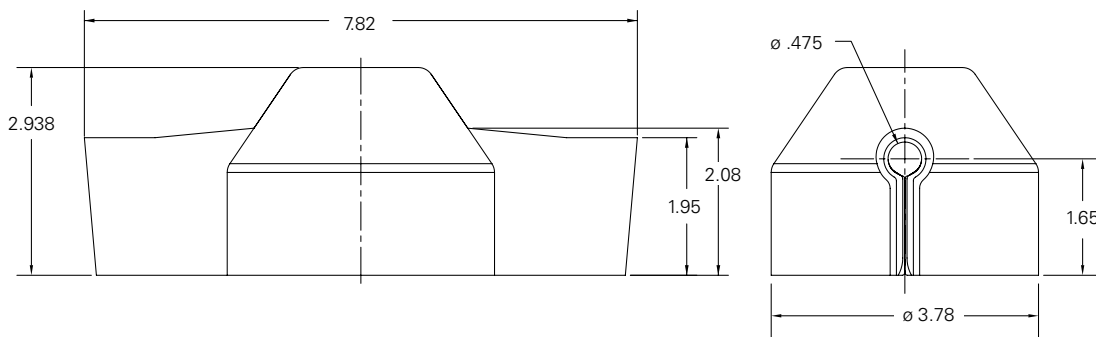

Figure 9. Line terminal wildlife guard (catalog number AV698X1C) (all dimensions in inches)

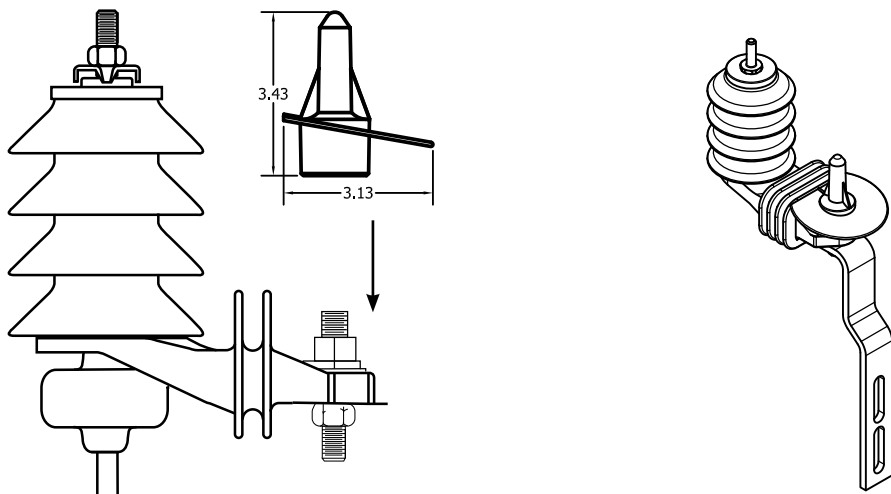

Figure 10. Ground terminal wildlife guard (catalog number AV731X1C) (all dimensions in inches); left shows attachment of ground terminal wildlife guard, right images shows ground terminal wildlife guard completely installed

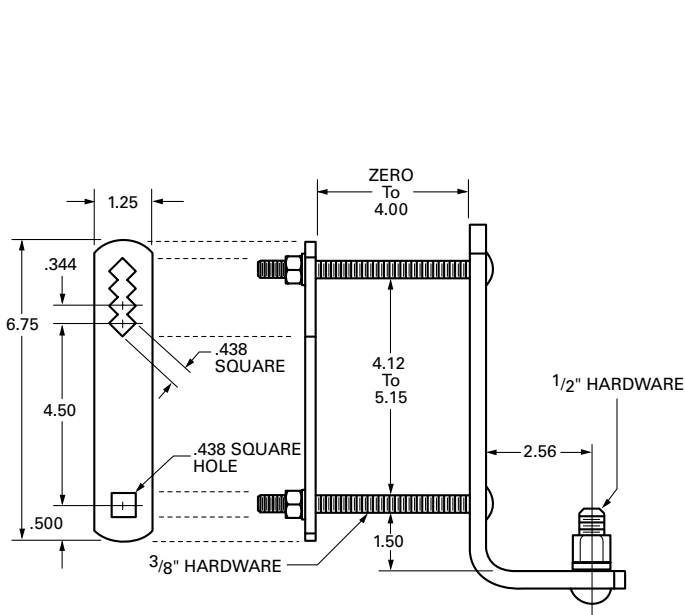

Figure 11. NEMA cross-arm bracket (catalog number AM35A1) can be specified with a "B" in Digit 13 (all dimensions in inches)

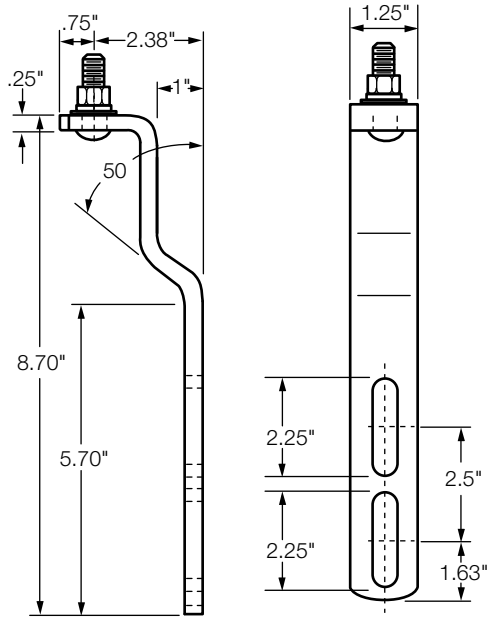

Figure 12. Standard transformer mounting bracket for 3-24 kV arrester (catalog number AM36A2) can be specified with a "C" in Digit 13 (all dimensions in inches)

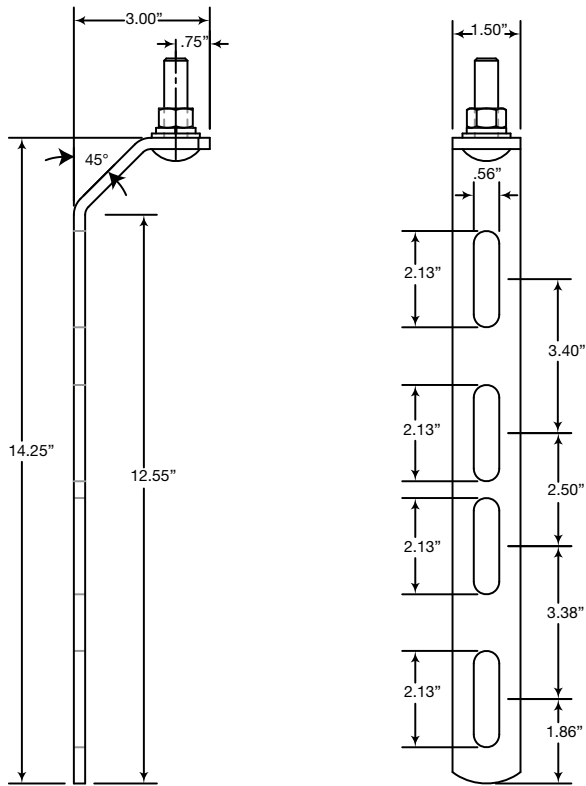

Figure 13. Standard transformer mounting bracket for 27-36 kV arrester (catalog number AH46A2) can be specified with a "C" in Digit 13 (all dimensions in inches)

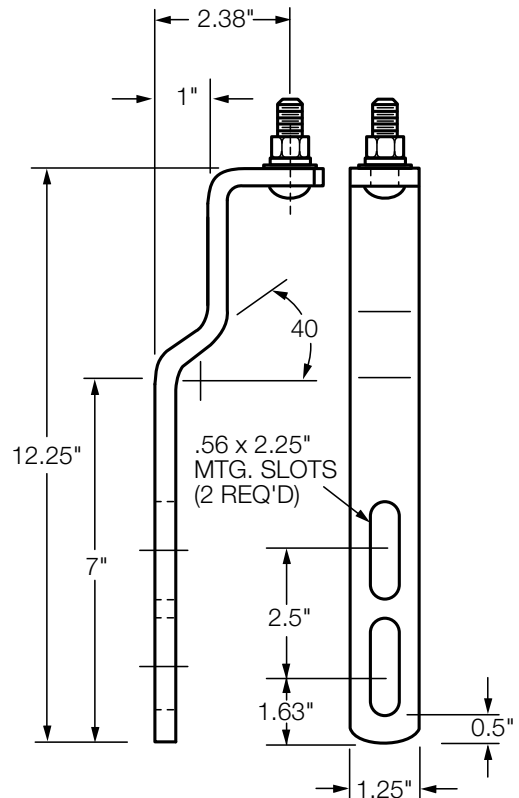

Figure 14. Optional transformer mounting bracket (catalog number AM36A3) can be specified with an "N" in Digit 13 (all dimensions in inches)

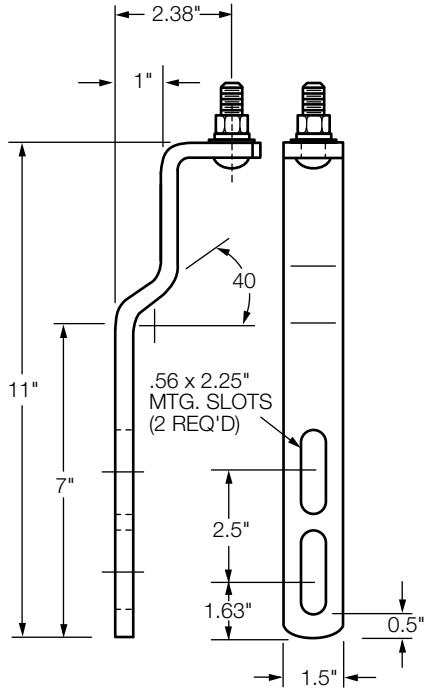

Figure 15. Optional transformer mounting bracket (catalog number AM36A1) can be specified with an "S" in Digit 13 (all dimensions in inches)

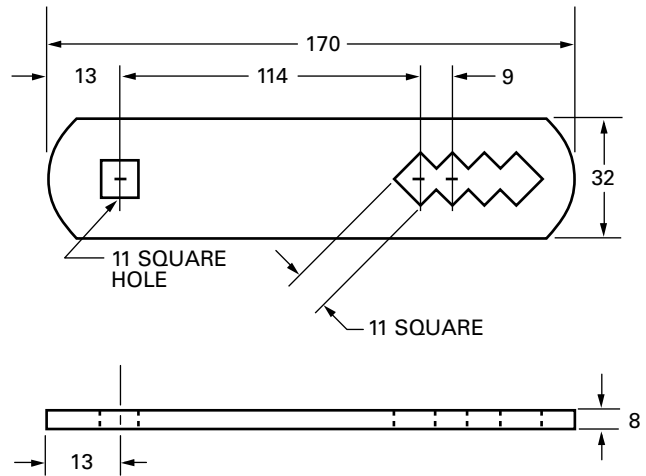

Figure 16. Conductive base mounting for use with 3/8 inch hardware, can be specified with a "2" in Digit 12 (requires "0" in Digit 10, "D" in digit 11) (all dimensions in inches)

Additional information

- MN235006EN, UltraSIL Housed Distribution-Class MOV Arrester Installation Instructions
- B235-08033, Taking Protection to the Extremes, the Evolution Surge Arrester
- B235-08022, Superior Protection for Arresters and Wildlife
- CP0804, UltraSIL Polymer-Housed Evolution Surge Arrester Certified Test Report
- CP1012, UltraSIL Polymer-Housed Evolution Surge Arrester Design Test

This page intentionally left blank.

Eaton
1000 Eaton Boulevard
Cleveland, OH 44122
United States
Eaton.com

Eaton's Power Systems Division
2300 Badger Drive
Waukesha, WI 53188
United States
Eaton.com/cooperpowerseries

© 2023 Eaton
All Rights Reserved
Printed in USA
Publication No. CA235018EN / ZD27776
July 2023

Eaton is a registered trademark.

All trademarks are property
of their respective owners.

For Eaton's Cooper Power series
Evolution surge arrester product
information, call 1-877-277-4636 or
visit: www.eaton.com/cooperpowerseries.