

# 600 A 15 kV class bushing adapter for T-OP™ II connector system (including LRTP and bushing extender)



## General

Eaton converts its standard Cooper Power™ series 600 A deadbreak interface to a standard 200 A loadbreak interface with our 600 A, 15 kV Class bushing adapter for our T-OP II connector systems allowing for safe testing and grounding. It meets all the requirements of IEEE Std 386™-2006 standard – “Separable Insulated Connector Systems” and is 200 A three-phase switching and three-phase fault close rated.

The 600 A, 15 kV class bushing adapter is a factory assembled loadbreak reducing tap plug (LRTP) and bushing extender. Included separately with the bushing adapter kit is an extended length copper alloy stud. Used with Eaton's Cooper Power series 200 A insulated protective cap, M.O.V.E. arrester, grounding elbow or loadbreak elbow connector; a bushing adapter provides a fully shielded, submersible, separable connection that meets the requirements of IEEE Std 386™-2006 standard.

## LRTP/bushing extender

An LRTP and a bushing extender can be purchased separately and assembled into a bushing adapter. The LRTP provides a means for live testing and visibly grounding and separating 600 A “T” type terminators.

The LRTP has a continuous copper/copper alloy current path from the female contact to the stationary threads. No aluminum current carrying components are used. The LRTP also has an ablative arc interrupter with excellent de-ionizing properties. The body is molded of high quality peroxide cured EPDM insulation and has a molded semiconductive EPDM shield. Three molded drain wire tabs are provided to allow attachment of a drain lead to ensure deadfront construction.

**EATON**

*Powering Business Worldwide*

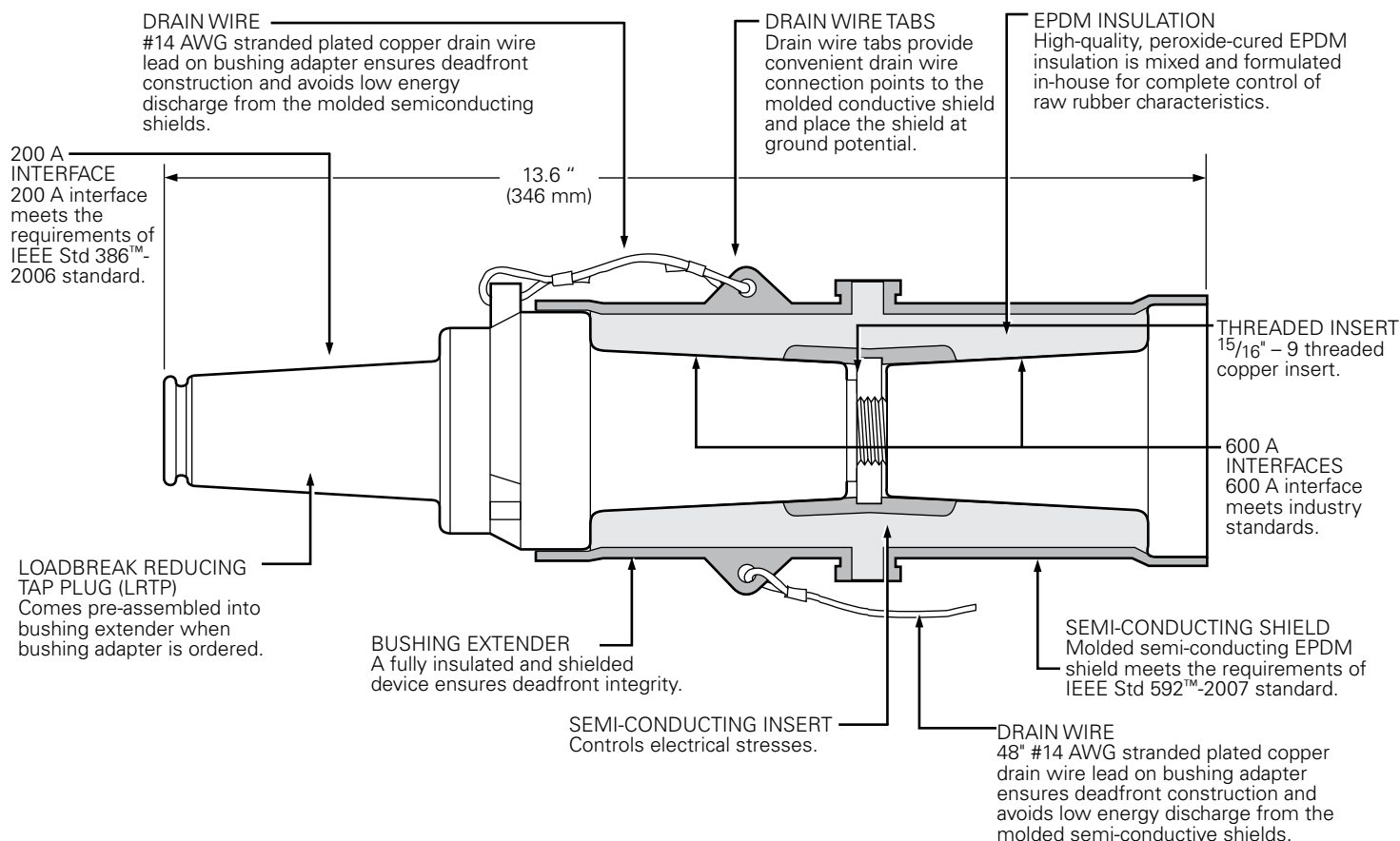

Figure 1. Catalog number DBA615 bushing adapter with 200 A and 600 A interfaces.

Note: Dimensions given are for reference only.

### Installation

The bushing adapter is installed on a de-energized 600 A interface with an extended length copper alloy stud (see Figure 4), provided with the bushing adapter kit, using a combined operating and test/torque tool (see Figure 8). Refer to Service Information Section S600-59-1 for additional installation instructions.

Note: The installation of the adapter can also be accomplished using a separate operating and testing tool (see Figure 6) and torque tool (see Figure 7) or 5/16" hex rod (see Figure 9).

#### L RTP/bushing extender

When an L RTP is purchased separately from the bushing extender, it has a factory installed alignment segment. The alignment segment of the L RTP is threaded into the copper threaded insert of the bushing extender. When proper torquing and seating of the L RTP is achieved, the alignment segment shear pin disengages the alignment segment for removal. The assembled L RTP and bushing extender is equivalent to the bushing adapter. (Refer to Service Information Section S600-59-1 for additional installation instructions.)

### Production tests

Tests are conducted in accordance with IEEE Std 386™-2006 standard.

- ac 60 Hz 1 Minute Withstand
  - 34 kV
- Minimum Corona Voltage Level
  - 11 kV

Tests are conducted in accordance with Eaton requirements.

- Physical Inspection
- Periodic Dissection
- Periodic Fluoroscopic Analysis

Table 1. Voltage Ratings and Characteristics

Description	kV
Standard Voltage Class	15
Maximum Rating Phase-to-Phase (L RTP 200 A interface only)	14.4
Maximum Rating Phase-to-Ground	8.3
ac 60 Hz 1 Minute Withstand	34
dc 15 Minute Withstand	53
BIL and Full Wave Crest	95
Minimum Corona Voltage Level	11

Voltage ratings and characteristics are in accordance with IEEE Std 386™-2006 standard.

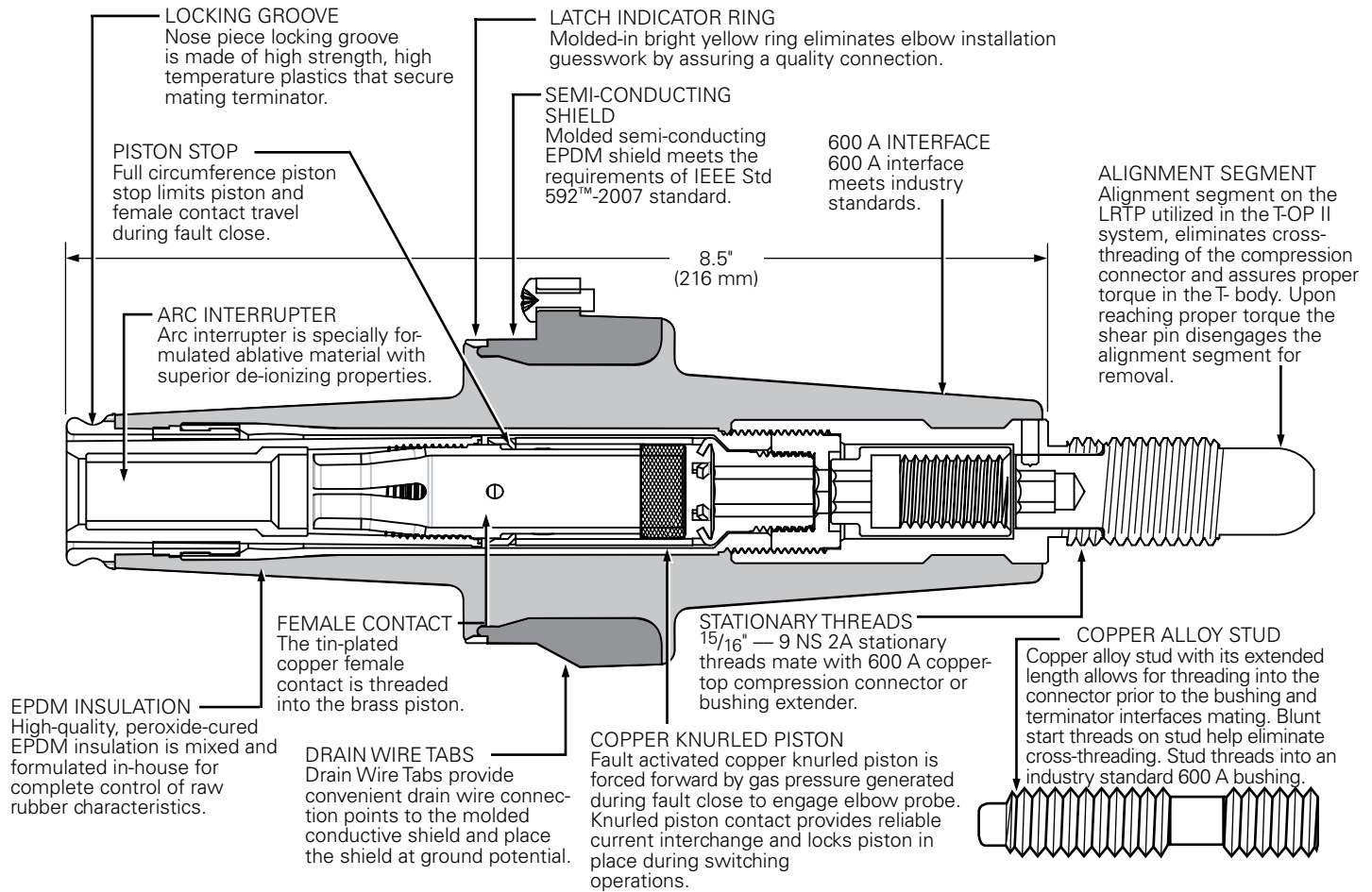

Figure 2. Catalog Number L RTP615.

**Loadbreak Reducing Tap Plug with 200 A and 600 A interfaces. Field proven, all copper/copper alloy current path ensures the coolest operating temperatures and reliability.**

**Note:** Dimensions given are for reference only.

Table 2. Current Ratings and Characteristics

Description	Amperes
<b>600 A Interface</b>	
Continuous	600 A rms
Short Time	25,000 A rms symmetrical for 0.17 s
	10,000 A rms symmetrical for 3.0 s
<b>200 A Interface*</b>	
Continuous	200 A rms
Switching	10 operations at 26.3 A rms at 14.4 kV
Fault Closure	10,000 A rms symmetrical at 26.3 kV after 10 switching operations for 0.17 S
Short Time	10,000 A rms symmetrical for 0.17 s
	3,500 A rms symmetrical for 3.0 s

Current ratings and characteristics are in accordance with IEEE Std 386™-2006 standard.

\* System design and protection must recognize the ratings of 200 A interface.

### Ordering information

To order 15 kV Class bushing adapter kits and loadbreak reducing tap plugs for T-OP II connector system, see Table 3.

Table 3. L RTP and Bushing Adapter Kits

Description	Catalog Number
Bushing Adapter (Fig. 1)	DBA615
Loadbreak Reducing Tap Plug (Fig. 2)	L RTP615
Bushing Extender (Fig. 3)	DBE625

Each Bushing Adapter Kit contains:

- Bushing Adapter
- Copper Alloy Stud
- Shipping Cap (not for energized operation)
- Silicone Lubricant
- Installation Instruction Sheet

Each L RTP Kit contains:

- Loadbreak Reducing Tap Plug
- Copper Alloy Stud
- Shipping Cap (not for energized operation)
- Silicone Lubricant
- Installation Instruction Sheet

**Table 4. Replacement Parts**

Description	Catalog Number
Copper Alloy Stud (Fig. 4)	Stud-T

**Table 5. Tools and Accessories**

Description	Catalog Number
Operating and Testing Tool with Cap (Fig. 6)	OT615
Torque Tool (Fig. 7)	TQHD625
T-Wrench (Fig. 5)	TWRENCH
Combined Operating and Test/Torque Tool (Fig. 8)	OTTQ615
5/16" Hex Shaft with 3/8" Socket Drive Tool (Fig. 9)	HD625



**Figure 3. Catalog Number DBE625.**

The twin 600 A interfaces of the Bushing Extender allow installation on standard de-energized 600 A deadbreak interfaces for coupling loadbreak reducing tap plugs, connecting plugs and apparatus bushings. When assembled to mating apparatus, the bushing extender provides a completely submersible, fully shielded unit that meets the requirements of IEEE Std 386™-2006 standard. Refer to Service Information Section S600-59-3 for additional installation instructions.

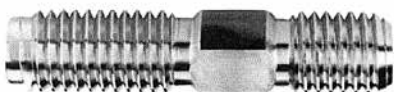

**Figure 4. Catalog Number STUD-T.**

The Copper Alloy Stud with its extended length allows for threading into the connector prior to mating the bushing and terminator interfaces. Blunt start threads on the stud help eliminate cross-threading. Stud threads into an industry standard 600 A bushing.



**Figure 5. Catalog Number TWRENCH.**

The T-Wrench is used to install the Loadbreak Reducing Tap Plug into the Bushing Extender.



**Figure 6. Catalog Number OT615.**

The Operating and Testing Tool is used with a hotstick to test for circuit de-energization and to install and remove a 15 kV Class LRTP equipped connector from an apparatus tap. The standard tool is equipped with a molded EPDM rubber cap to ensure tool seating and gripping of the T-OP II connector.



**Figure 7. Catalog Number TQHD625.**

The Torque Tool is required to check the torque of a 15 kV Class T-OP II deadbreak connector or bushing adapter when it is installed on a 600 A bushing interface. It is precision calibrated and shotgun stick operable.



**Figure 8. Catalog Number OTTQ615.**

The combination Operating and Test/Torque Tool is used with a hotstick to test for circuit de-energization and to install and remove a 15 kV Class LRTP equipped connector from an apparatus tap. The standard tool is equipped with a molded EPDM rubber cap and torque limiter to allow proper tool seating and gripping of the T-OP II connector. It also ensures that the connector has been properly torqued into the mating bushing.



**Figure 9. Catalog Number HD625.**

5/16" Hex Shaft with 3/8" socket drive tool.

Eaton  
1000 Eaton Boulevard  
Cleveland, OH 44122  
United States  
Eaton.com

Eaton's Cooper Power Systems Division  
2300 Badger Drive  
Waukesha, WI 53188  
United States  
Eaton.com/cooperpowerseries

© 2015 Eaton  
All Rights Reserved  
Printed in USA  
Publication No. CA650041EN

Eaton, Cooper Power, and T-OP are trademarks of Eaton in the U.S. and other countries. You are not permitted to use these trademarks without the prior written consent of Eaton.  
IEEE Std 386™-2006 and IEEE Std 592™-2007 standards are trademarks of the Institute of Electrical and Electronics Engineers, Inc., (IEEE). This publication/product is not endorsed or approved by the IEEE.

For Eaton's Cooper Power series T-OP II connector product information call 1-877-277-4636 or visit: [www.eaton.com/cooperpowerseries](http://www.eaton.com/cooperpowerseries).