

600 A 15 kV class BT-TAP™ deadbreak connector



General

Eaton terminates high-voltage underground cable to transformers, switches, switchgear and other apparatus with its Cooper Power™ series 600 A 15 kV Class BT-TAP™ deadbreak connector. It is designed for use with unthreaded connectors, to easily retrofit existing 600 A BOLT™ installations or in new installations where a 200 A interface is required and where the system will not need to be frequently operated. If the system will be frequently operated to sectionalize or to achieve a visible break or ground, Eaton recommends its Cooper Power series T-OP™ II Connector System. (See catalog section CA650017EN.) The BT-TAP deadbreak connector is fully shielded, submersible and meets the requirements of IEEE Std 386™-2016 standard – “Separable Insulated Connector Systems”.

The 200 A, three-phase rated loadbreak interface provides a means for obtaining a direct conductor test, visible ground and provides a convenient location for an Eaton's Cooper Power series M.O.V.E. arrester or grounding elbow.

Eaton offers an optional capacitive test point similar to test points on its Cooper Power series 200 A elbow connectors. This allows use of Eaton's Cooper Power series Type “TPR” faulted circuit indicators, and provides a hotstick operable means of determining circuit condition when used with high impedance voltage sensing devices designed for test points.

BT-TAP connectors are designed for use on solid dielectric cable (XLPE or EPR) with extruded semi-conductive shields and concentric neutral, with or without a jacket.

Installation on jacketed concentric neutral cable may require additional sealing material. Cold shrinkable adapters are available for tape shield, linear corrugated, unshield, and drain wire cables for use with deadbreak connectors.

EAT•N

Powering Business Worldwide

900 AMP rating

The BT-TAP connector is rated for 900 A continuous when used with a coppertop compression connector or shear bolt, copper stud, and copper bushing or junction. If a 900 A rating is desired, specify a "C" as the 11th digit when determining your part number. See Step 3, page 4.

Interchangeability

Eaton conforms to the electrical, mechanical and dimensional requirements of IEEE Std 386™-2016 standard with its Cooper Power series 600 A deadbreak connectors. The connectors can be used on any comparably rated bushing interface that also meets the requirements of this standard. In addition, all T-bodies, cable adapters, insulating plugs and compression connectors are designed to be interchangeable with those currently available from other major manufacturers that also certify their components to IEEE Std 386™-2016 standard.

Installation

The T-body is assembled onto prepared cable with an unthreaded compression or shear bolt connector. The stud provided with the kit, is torqued onto a de-energized 600 A bushing. Using a T-WRENCH, the loadbreak reducing tap plug is threaded onto the stud drawing the entire assembly tight to the apparatus bushing. The assembly is then torqued to the apparatus bushing using a torque wrench. Refer to *Service Information MN650004EN, 600 A 15 and 25 kV Class BT-TAP Connector System Installation Instructions* for details.

Production tests

Tests conducted in accordance with IEEE Std 386™-2016 standard:

- ac 60 Hz 1 Minute Withstand
 - 34 kV
- Minimum Partial Discharge Extinction Voltage
 - 11 kV

Tests conducted in accordance with Eaton requirements:

- Physical Inspection
- Periodic Dissection
- Periodic X-ray Analysis

Table 1. Voltage Ratings and Characteristics

Description	kV
Standard Voltage Class	15
Maximum Rating Phase-to-Phase (loadbreak reducing tap plug only)	14.4
Maximum Rating Phase-to-Ground	8.3
ac 60 Hz 1 Minute Withstand	34
dc 15 Minute Withstand	53
BIL and Full Wave Crest	95
Minimum Partial Discharge Extinction Voltage	11

Voltage ratings and characteristics are in accordance with IEEE Std 386™-2016 standard.

Table 2. Current Ratings and Characteristics

Description	Amperes
600 A Interface	
Continuous	600 A rms (Aluminum) 900 A rms (Copper or Shear Bolt)
4 Hour Overload	900 A rms (Aluminum) 1,200 A rms (Copper or Shear Bolt)
Short Time (Aluminum)	25,000 A rms symmetrical for 0.17 s 10,000 A rms symmetrical for 4.0 s
Short Time (Copper or Shear Bolt)	40,000 A rms symmetrical for 0.17 s 27,000 A rms symmetrical for 4.0 s
200 A Interface*	
Continuous	200 A rms
Switching	10 operations at 200 rms at 14.4 kV phase-to-phase
Fault Closure	10,000 A rms symmetrical at 14.4 kV phase-to-phase for 0.17 s after 10 switching operations
Short Time	10,000 A rms symmetrical for 0.17 s 3,500 A rms symmetrical for 3.0 s

Current ratings and characteristics are in accordance with IEEE Std 386™-2016 standard.

* System design and protection must recognize the ratings of 200 A interface.

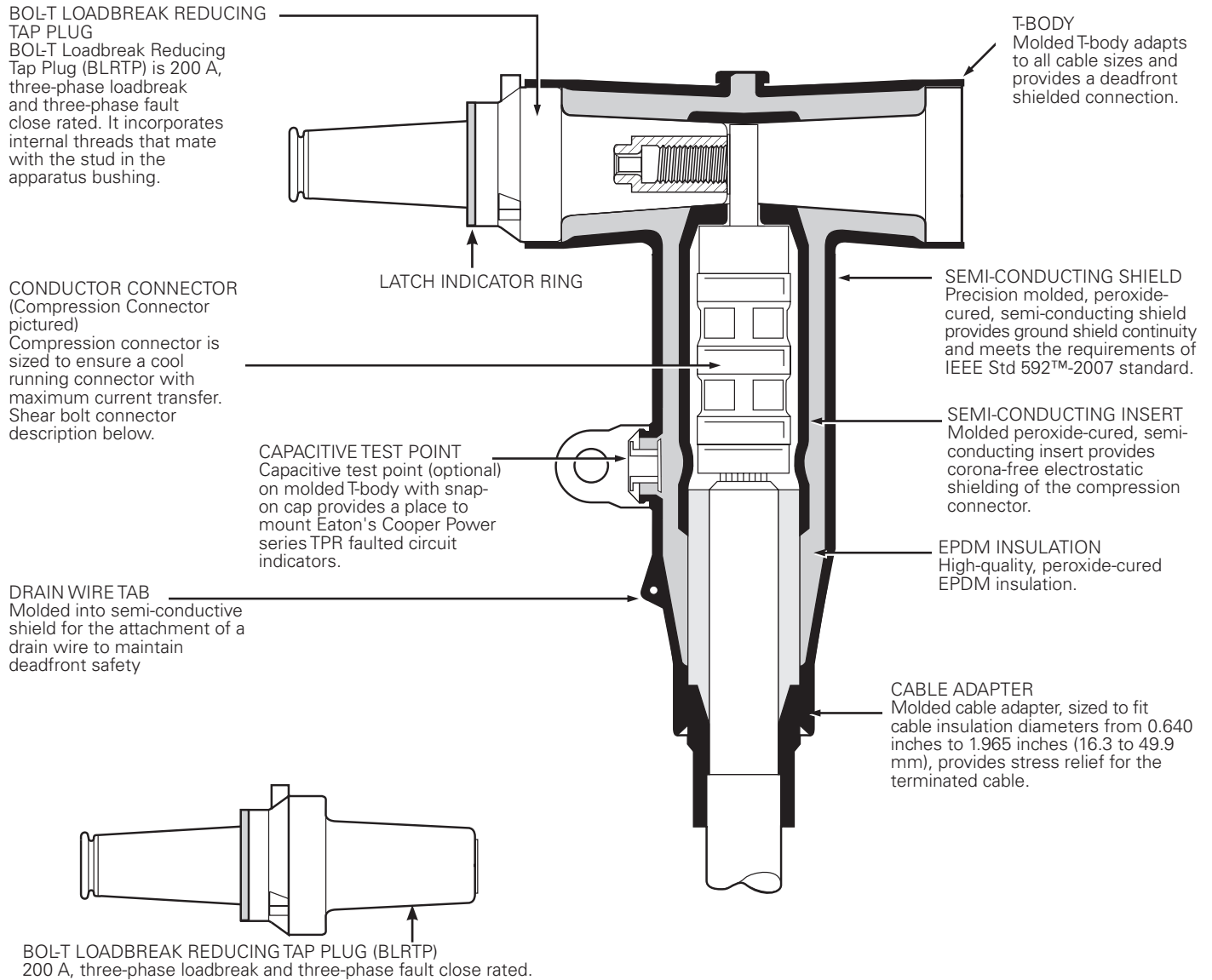

Figure 1. Cutaway drawing illustrates design features.

Optional features

Protective cap

200 A insulated protective cap fits over loadbreak reducing tap plug for deadfront shielding.

Capacitive test point

Capacitive test point on molded T-body, with snap-on cap, provides a place to mount Eaton's Cooper Power series TPR faulted circuit indicators.

Shear bolt connector (optional)

Bolted cable lug is fitted with stepless bolts, which shear off when optimum contact force has been reached. Provides electrical continuity for copper and aluminum conductors while eliminating need for dies and compression tools.



Figure 2. Shear bolt connector

BT-TAP connector kit – catalog numbering system

Build the 12 digit catalog number for a 15 kV BT-TAP Kit by following the steps given below. The first 6 digits are always "BTP615"; only digits 7 through 12 need to be selected.

1	2	3	4	5	6	7	8	9	10	11	12	13	14
B	T	P	6	1	5								

Catalog Number Digits:

1, 2 & 3 = "BTP," BT-TAP Connector System

4 = "6," 600 A System

5 & 6 = "15," 15 kV Class Bushing Interface

Step 1 – Select Digits 7 and 8 Cable Adapter Range Code

Determine the cable's diameter over the electrical insulation as shown in Figure 3 (including tolerances).

Then identify a cable range from Table 3 that covers the minimum and maximum insulation diameters.

Select the correct CABLE RANGE CODE from Table 3.

Table 3. Cable Insulation Diameter Range

Inches	mm	Code
0.610-0.970	15.5-24.6	AB
0.750-1.080	19.1-27.4	CC
0.970-1.310	24.6-33.3	DD
1.090-1.470	27.7-37.3	EE
1.260-1.640	32.0-41.7	FF
1.360-1.710	34.5-43.4	GG
1.510-1.850	38.4-47.0	HH
1.700-1.970	43.2-50.0	JJ

Step 2 – Select Digits 9 and 10 Conductor Code

Identify the conductor size and type in Table 4 and select the CONDUCTOR CODE from the appropriate (compression or shear bolt) column.

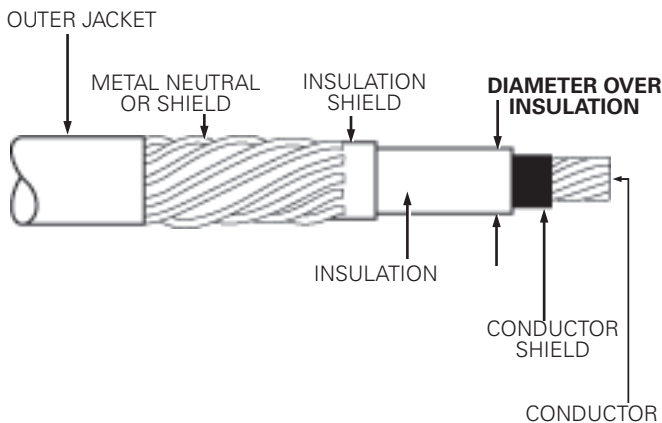

Figure 3. Illustration showing typical construction of medium voltage underground cable.

Step 3 – Select Digit 11

Determine whether 600 A or 900 A Rating is required.

"A" = 600 A Rating (Aluminum Compression or Shear Bolt Connector, Aluminum Stud and Aluminum Reducing Tap Plug)

"C" = 900 A Rating (Coppertop Compression Connector or Shear Bolt Connector, Copper Stud and Copper Reducing Tap Plug)

Step 4 – Select Digit 12

Determine if a standard length or extended length stud is required.

S = Standard Length

L = Extended Length

Step 5 – Select Digit 13 (optional)

Determine if the T-body should have a test point.

T = Test Point on T-body

If no test point is required, do not include a 13th digit.

Step 6 – Select Digit 14 (optional)

Determine whether a 15 kV, 200 A protective cap is required in the kit.

C = Protective Cap

If no cap is required, do not include a 14th digit.

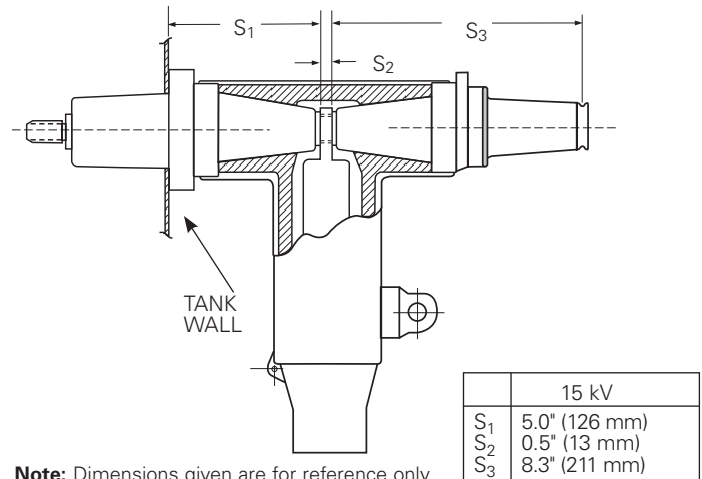

Note: Dimensions given are for reference only.

Figure 4. BT-TAP profile and stacking dimensions from Figure 11A of IEEE Std 386™-2016 standard.

Table 4. Conductor Size and Type

Compression Connector					Shear Bolt Connector					
Concentric or Compressed		Compact or Solid		Compression Conductor Code	Cable Conductor Size			Shear Bolt Connector		
AWG or kcmil	mm ²	AWG or kcmil	mm ²		AWG or kcmil		mm ² Standard Sizes	Conductor Code	Catalog Number	
AWG or kcmil	mm ²	AWG or kcmil	mm ²	Compression Conductor Code	Compact	Compressed	Concentric	mm ² Standard Sizes	Conductor Code	Catalog Number
No Connector				0	1/0	1/0	1/0	50		
#2	35	1	-	11	2/0	2/0	2/0	70		
#1	-	1/0	50	12	3/0	3/0	3/0	-	S1	CDT630SB150
1/0	50	2/0	70	13	4/0	4/0	4/0	95		
2/0	70	3/0	-	14	250	250	250	120		
3/0	-	4/0	95	15	350	-	-	150		
4/0	95	250	120	16	-	350	350	185		
250	120	300	-	17	500	500	500	240	S3	CDT630SB300
300	-	350	-	18	600	600	600	300		
350	-	400	185	19	700	-	-	-		
400	185	450	-	20	-	700	700	-		
450	-	500	240	21	750	750	750	-	S4	CDT630SB400
500	240	600	300	22	800	800	-	400		
600	300	700	-	23	900	-	-	-		
650	-	750	-	24	-	-	800	-		
750	-	900	-	25	-	900	900	-	S5	CDT900SB500
900	-	1000	500	26	1000	1000	1000	500		
1000	500	-	-	27						
1250	630	1250	-	28						

Effective November 2020

To order replacement parts and tools, refer to Table 5.

To order replacement compression connectors and cable adapters for a BT-TAP Connector System, see section CA650007EN "Deadbreak Accessories, Tools and Replacement Parts."

Table 5. Replacement Parts and Tools

Description	Catalog Number
T-body without Test Point	DT625
T-body with Test Point	DT625T
Hex Wrench	HD625
Aluminum Stud, Standard Length	STUD-A
15 kV, 200 A Insulated Protective Cap	LPC215
BOL-T Loadbreak Reducing Tap Plug "BLRTP", aluminum	BLRTP615A
BOL-T Loadbreak Reducing Tap Plug "BLRTP", copper	BLRTP615C
BOL-T Loadbreak Reducing Tap Plug "BLRTP", aluminum with stud	BLRTP615AS
BOL-T Loadbreak Reducing Tap Plug "BLRTP", aluminum with stud, Factory installed	BLRTP615ASP
BOL-T Loadbreak Reducing Tap Plug "BLRTP", copper with stud	BLRTP615CS
BOL-T Loadbreak Reducing Tap Plug "BLRTP", copper, Factory installed	BLRTP615CSP
Aluminum Stud, Extended Length	STUDAL
Copper Stud, Standard Length	STUD-C
Copper Stud, Extended Length	STUDCL

Note: The standard packaging for the BLRTP is a sealed plastic bag. Add "X" to the end of the catalog number for an individual box.

This page intentionally left blank.

Eaton
1000 Eaton Boulevard
Cleveland, OH 44122
United States
Eaton.com

Eaton's Power Systems Division
2300 Badger Drive
Waukesha, WI 53188
United States
Eaton.com/cooperpowerseries

© 2020 Eaton
All Rights Reserved
Printed in USA
Publication No. CA650002EN
November 2020

Eaton is a registered trademark.
All other trademarks are property
of their respective owners.

For Eaton's Cooper Power series BT-TAP
deadbreak connector product information call
1-877-277-4636 or visit:
www.eaton.com/cooperpowerseries.