

ELSG full-range current-limiting fuse



General

Eaton designs its Cooper Power™ series ELSG full-range current-limiting fuse for use in pad-mounted switchgear filled with Envirotemp™ FR3™ fluid, mineral oil or approved equivalent. It may also be used to protect power transformers, feeders and other equipment that can benefit from its energy-limiting properties. The fuse provides consistent clearing of low currents as well as reliable high speed interruption of high magnitude short circuit currents. Its current-limiting capability limits both peak current magnitude and fault duration, thus limiting the let-through energy.

ELSG fuses have both the low current and high current clearing sections in one housing. This eliminates expulsion by-products discharging into the oil when the fuse operates. Concerns associated with mis-coordination of separate expulsion and current-limiting fuse sections in the field are eliminated. Also, field testing the current-limiting section when the expulsion section operates is also eliminated.

The E-rated ELSG fuses have time-current characteristics that coordinate easily with other upstream and downstream protective devices. The MSLE version of the ELSG fuses are interchangeable with the K-MATE® SL fuse assembly manufactured by Hubbell Incorporated.

ELSG fuses have been tested and meet all requirements set forth in IEEE Std C37.40™-1993, IEEE Std C37.41™-1988, and IEEE Std C37.46™-1981 standards.

Fuses shown on left, top to bottom, are single 2" diameter fuse, single 3" diameter fuse, double-barrel fuse assembly, and triple-barrel assembly fuse.

EAT•N

Powering Business Worldwide

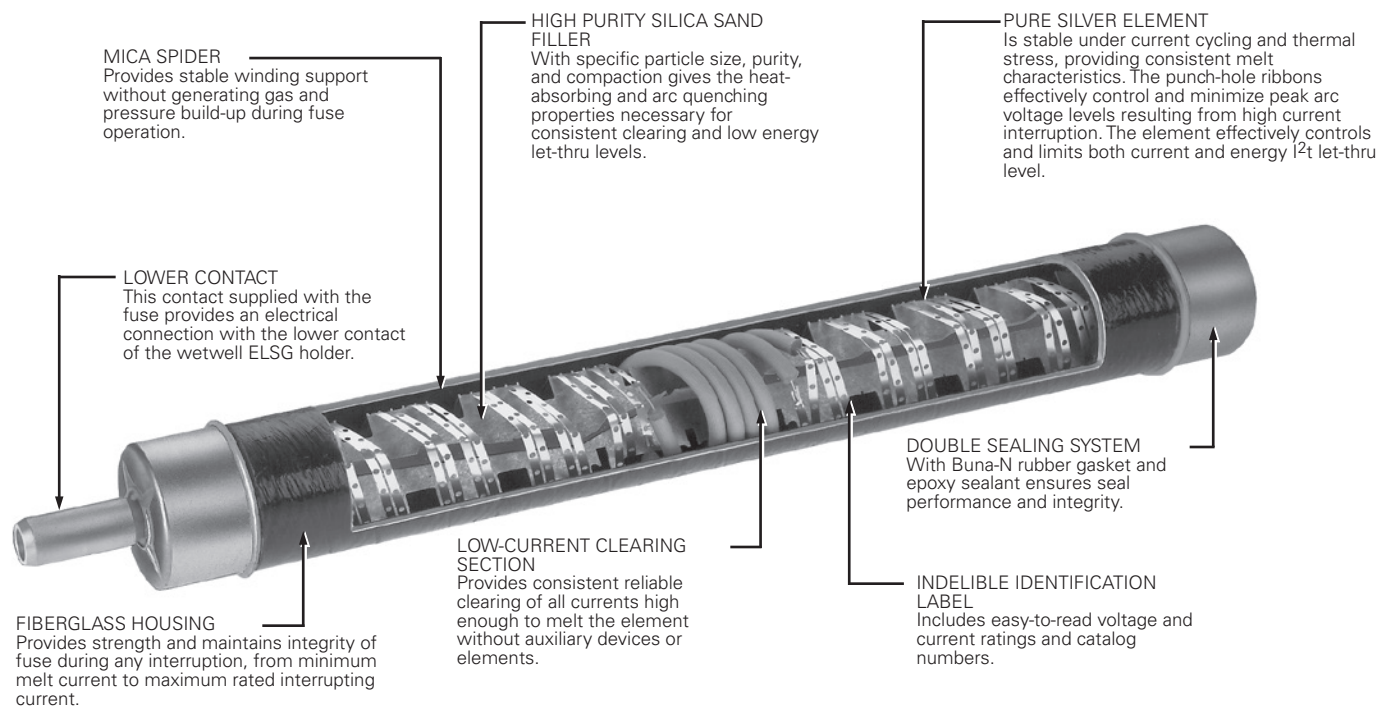

Figure 1. Cutaway illustration of the ELSG fuse

Table 1. Maximum interrupting current (rms symmetrical)

	8.3 kV	15.5 kV	23 kV
ELSG E-Rated	50,000 A	50,000 A 20,000 A (65E-150E for M83M series; 120E & 150E for M01M series)	50,000 A 12,200 A (50E-100E)
ELSG MSLE Version	31,000 A	20,000 A	12,200 A

Table 2. ELSG fuse electrical characteristics for 15 kV Wetwell Holders

Fuse rating		8.3 kV	15.5 kV ^a
IEEE E-Rating	Continuous Current Rating	Minimum Melt I^2t (A ² • s)	Maximum Let-through I^2t (A ² • s)
4	9	820	5,000
8	14	820	5,000
12	18	1,460	9,800
15	24	2,280	13,800
20	34	2,280	13,800
25	35	3,280	27,300
30	46	9,110	53,400
40	53	9,110	53,400
50	65	13,120	69,200
50	96	—	—
60	76	17,860	96,700
65	92	—	36,440
65	95	18,000	72,000
80	106	—	36,440
80	125	40,000	130,000
100	130	—	52,480
100	155	72,000	220,000
120	150	—	72,000
125	180	111,000	420,000
150	200	—	118,000
MSLE version			
N/A	50	9,000	53,000
N/A	90	36,000	212,000

^a These ratings are the 15.5 kV, M83M fuse series for the 15 kV wetwell holder.

Installation

No special tools are required. The ELSG fuse assembly is lowered into the wetwell holder (see Catalog Section CA132019EN) of de-energized apparatus using a clampstick.

The ELSG fuses are shipped as complete assemblies ready to install. No adapters are needed with Eaton's Cooper Power series fuses. Refer to Installation Instruction Sheet MN132017EN for details.

Production tests

Tests are conducted in accordance with Eaton requirements.

- Physical Inspection
- I²t Testing
- Resistance Testing
- Helium Mass Spectrometer Leak Testing

Electrical characteristics

The ELSG fuses are given an "E" rated characteristic, which is described in IEEE Std C37.46™-1981 standard. The "E" rating defines a Time-Current Characteristic (TCC) curve reference "gate" for power fuse rating standardization.

E rating "gates": per IEEE Std C37.46™-1981 standard:

- 0-100E @ 300 sec, 200-240% of melting current or percent rating
- 125E-200E @ 600 sec, 220-264% of melting current or percent rating

Figure 2 shows an example of two different "100E" fuse TCC curves. Both meet IEEE® requirements for the 100E rating. The "E" rating does not define the continuous current rating allowable by the fuse and should not be used as the only characteristic to establish interchangeability with other "E" rated fuses.

To further provide operating performance characteristics, the ELSG fuses are tested to determine a continuous current rating. The continuous current rating is specified as being the maximum current the fuse can carry continuously without exceeding the temperature rises detailed in the IEEE® standards.

The electrical characteristics for the ELSG fuses that mount in the 15 kV wetwell holder are described in Table 2. Table 5 details the electrical characteristics for the ELSG fuses for the 25 and 35 kV wetwell holder.

The ELSG fuses are also available in the MSLE version. These fuses are designed as a continuous current rated fuse to meet the electrical and/or mechanical characteristics of the K-MATE® fuses manufactured by Hubbell Incorporated. Table 4 shows the cross reference between the ELSG MSLE version fuses and the K-MATE® SL fuses.

The TCC curves for ELSG E-rated and MSLE version fuses are shown in Table 3.

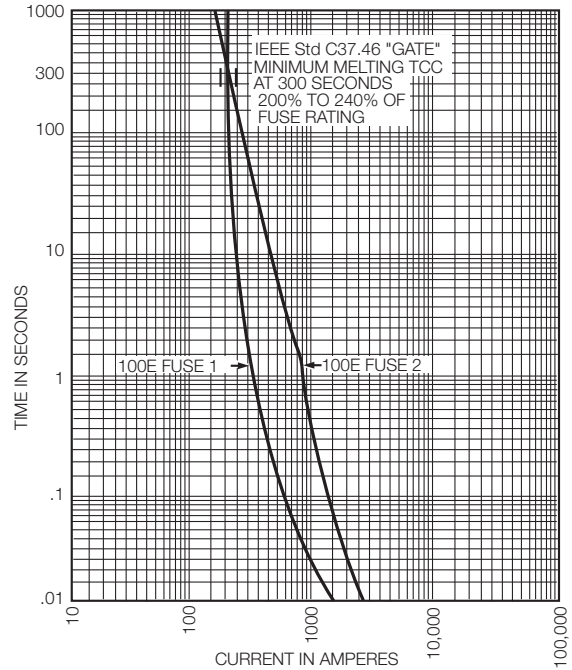

Figure 2. 100E rated current-limiting fuse "gate" per IEEE®

Table 3. ELSG Time Current Characteristic (TCC) curves

Voltage (kV)	TCC Curve number	Fuse design
8.3	R240-91-85	2" Dia. E-Rated (4E through 60E)
	R240-91-86	3" Dia. E-Rated (65E through 125E)
	R240-91-88	MSLE Version (50 & 90 A)
15.5	R240-91-85	2" Dia. E-Rated (4E through 150E for the 15.5 kV, M83M Series) and (4E through 60E, 120E & 150E for the 15.5 kV, M02M Series)
	R240-91-86	3" Dia. E-Rated (65E through 100E)
	R240-91-88	MSLE Version (50 & 90 A)
23	R240-91-89	2" Dia. E-Rated (4E through 100E)
	R240-91-88	MSLE Version (50, 90 & 135 A)
23 (long)*	R240-91-87	E-Rated (40E through 125E) Single barrel – 3" Diameter

* This special 23 kV ELSG fuse is extra long to fit into the long 35 kV class wetwell holder (P/N 3437322C06M). Consult factory for fuse catalog numbers.

Table 4. MLSE version ELSG fuse cross reference*

Single-phase Maximum voltage rating (kV)	MSLE Version ELSG Fuse Catalog number	Hubbell Inc. K-MATE® SL Assembly catalog number
8.3*	3593050MSLE	C705-0254 (SL-54)
	3593090MSLE	C705-0255 (SL-90)
15.5**	3594050MSLE	C705-0443 (SL-54)
	3594090MSLE	C705-0445 (SL-90)
23**	3595050MSLE	C705-0450 (SL-54)
	3595090MSLE	C705-0452 (SL-90)
	3595135MSLE	—

* Fuses are mechanically interchangeable and can typically be used for the same application.

** Fuses are both electrically and mechanically interchangeable.

Effective February 2021

Table 5. ELSG fuse electrical characteristics for 25 & 35 kV Wetwell Holder

Fuse Rating		15.5 kV		23.0 kV	
IEEE E-Rating	Continuous current rating	Minimum Melt I ² t (A ² • s)	Maximum Let-through I ² t (A ² • s)	Minimum Melt I ² t (A ² • s)	Maximum Let-through I ² t (A ² • s)
4	9	820	5,000	820	5,000
8	14	820	5,000	820	5,000
12	18	1,460	9,800	1,460	9,800
15	24	2,280	13,800	2,280	13,800
20	34	2,280	13,800	2,280	13,800
25	35	3,280	27,300	3,280	27,300
30	46	9,110	56,600	9,110	59,000
40	53	9,110	56,600	9,110	59,000
50	65	13,120	75,000	—	—
50	96	—	—	36,000	212,000
60	76	17,860	80,000	—	—
65	95	18,000	125,000	—	—
65	120	—	—	36,000	212,000
80	125	40,000	185,000	—	—
80	145	—	—	82,000	394,000
100	140	72,000	305,000	—	—
100	180	—	—	82,000	394,000
120	150	72,000	320,000	—	—
150	200	118,000	440,000	—	—
MSLE Version					
N/A	50	9,000	53,000	9,000	53,000
N/A	90	36,000	212,000	36,000	212,000
N/A	135	—	—	82,000	394,000

Dimensions and weights

15 kV switchgear

Table 6. ELSG E-rated fuse dimensional information* for 15 kV Wetwell Holders

Fuse rating				Figure number Reference
Voltage (kV)	IEEE E-Rating	Dimensions inches (mm) A	Weight lbs. (kg)	
8.3	4-60E	8.4 (213)	2.9 (1.3)	3
8.3	65-125E	16.0 (406)	9.0 (4.0)	4
15.5	4-60E	12.8 (325)	2.9 (1.3)	3
15.5	65-120E	12.8 (325)	12.2 (5.5)	5
15.5	150E	12.8 (325)	12.2 (5.5)	6

* Refer to Figures 3, 4, 5, and 6 for dimensional drawings.

Table 7. MSLE version ELSG fuse dimensional information* for 15 kV Wetwell Holders

Fuse rating				Figure number Reference
Voltage (kV)	Continuous current (A)	Dimensions inches (mm) A	Weight lbs. (kg)	
8.3	50	8.4 (213)	2.9 (1.3)	3
8.3	90	8.4 (213)	6.0 (2.7)	5

* Refer to Figures 3 and 5 for dimensional drawings.

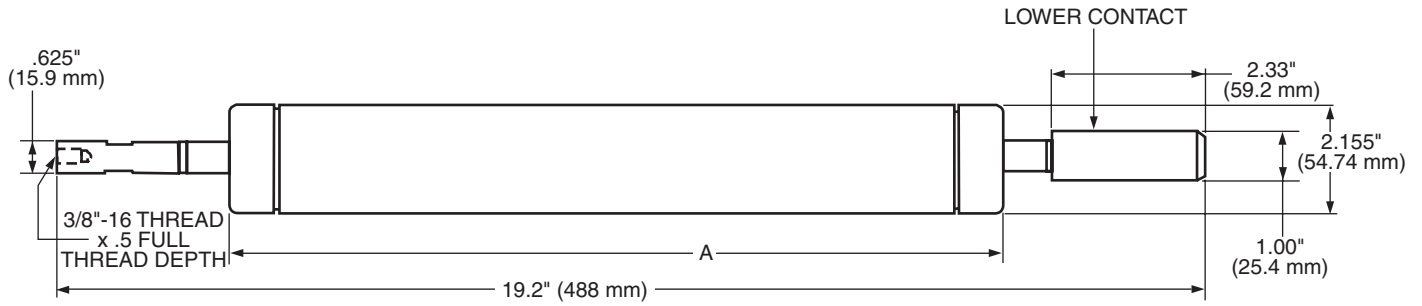

Figure 3. Dimensional information for single 2" diameter 8.3 kV and 15 kV E-rated and MSLE version ELSG fuses

Note: Dimensions are given in Tables 6 and 7.

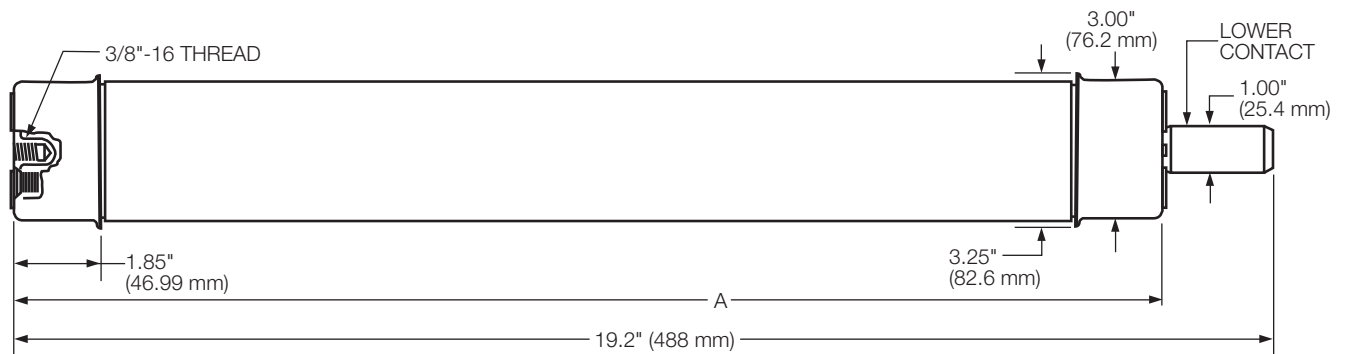

Figure 4. Dimensional information for E-rated 8.3 kV (65E-125E) version ELSG fuses

Note: Dimensions are given in Table 6.

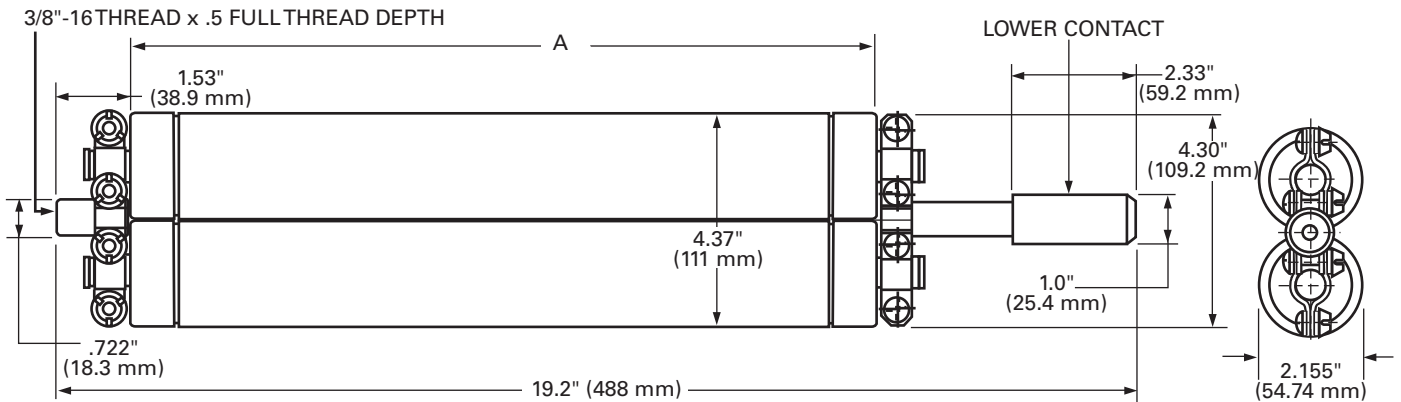

Figure 5. Dimensional information for E-rated 15.5 kV (65E-120E) and 8.3 kV (90 A) MSLE version ELSG fuses

Note: Dimensions are given in Table 6 and Table 7.

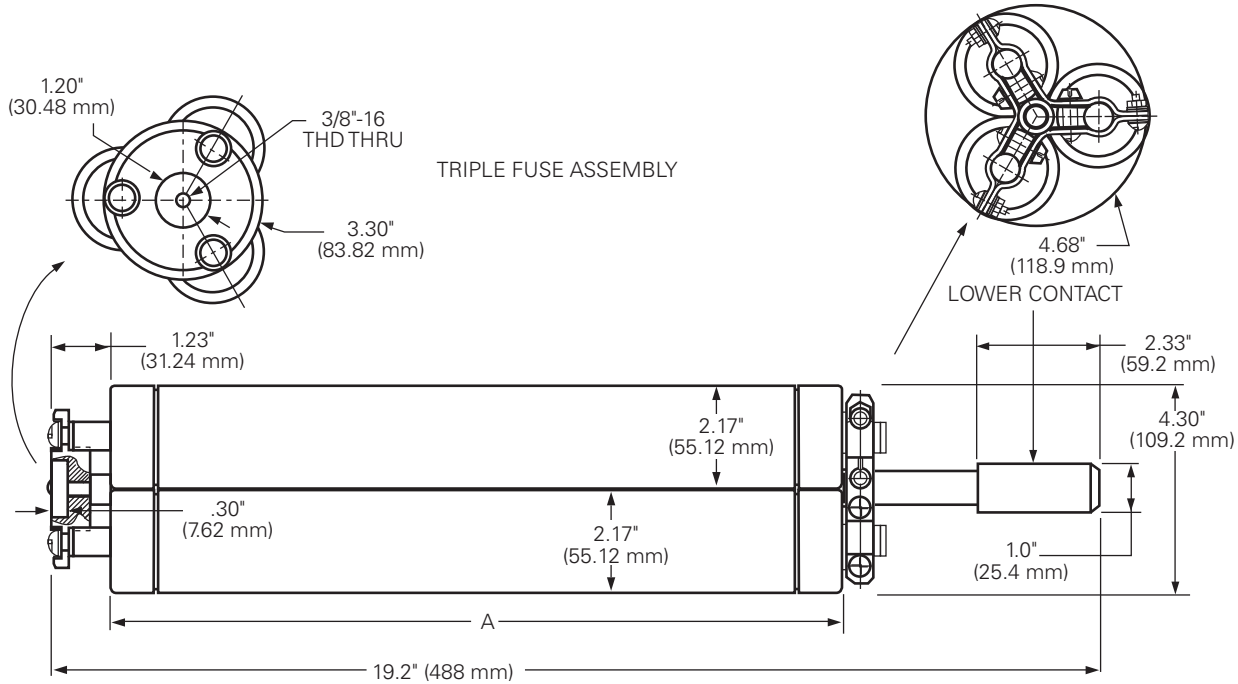

Figure 6. Dimensional information for E-rated 15.5 kV (150E) version ELSG fuses - 15 kV Wetwell Holder

Note: Dimensions are given in Table 6.

Dimensions and weights

25 and 35 kV switchgear

Table 8. ELSG E-rated fuse dimensional information* for 25 & 35 kV Wetwell Holder

Fuse rating				
Voltage (kV)	IEEE E-Rating	Dimensions inches (mm) A	Weight lbs. (kg)	Figure number reference
15.5	4-60E	12.8 (325)	3.8 (1.7)	7
15.5	65-100E	19.0 (483)	10.2 (4.7)	8
15.5	120E	12.8 (325)	12.2 (5.5)	9
15.5	150E	12.8 (325)	12.2 (5.5)	10
23.0	4-40E	15.6 (539)	4.4 (2.0)	7
23.0	50-65E	15.6 (539)	9.1 (4.1)	9
23.0	80-100E	15.6 (539)	14.0 (6.3)	11

* Refer to Figures 7, 8, 9, 10 and 11 for dimensional drawings.

Table 9. MSLE version ELSG fuse dimensional information* for 25 & 35 kV Wetwell Holder

Fuse rating				
Voltage (kV)	Continuous current (A)	Dimensions inches (mm) A	Weight lbs. (kg)	Figure number reference
15.5	50	12.7 (323)	3.8 (1.7)	7
15.5	90	12.7 (323)	7.8 (3.5)	9
23.0	50	15.6 (396)	4.4 (2.0)	7
23.0	90	15.6 (396)	9.1 (4.1)	9
23.0	135	15.6 (396)	14.0 (6.3)	11

* Refer to Figures 7, 9 and 11 for dimensional drawings.

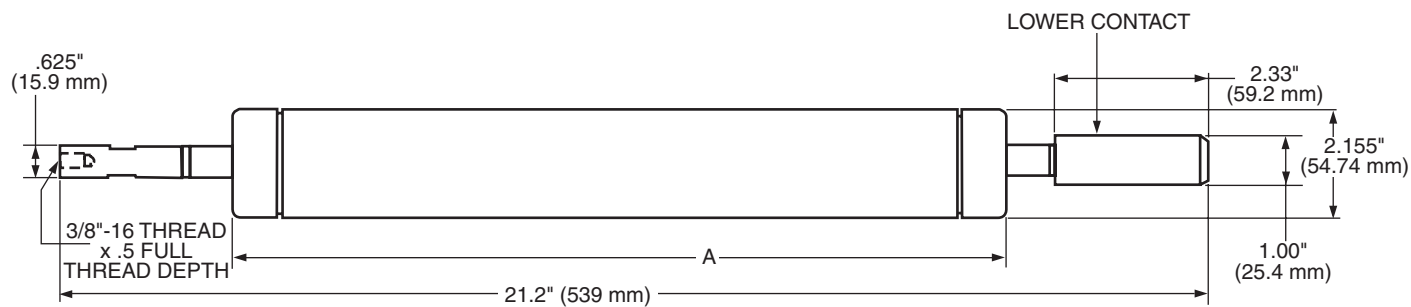

Figure 7. Dimensional information for single 2" diameter 15 kV and 23 kV E-rated and MSLE version ELSG fuses

Note: Dimensions are given in Tables 8 and 9.

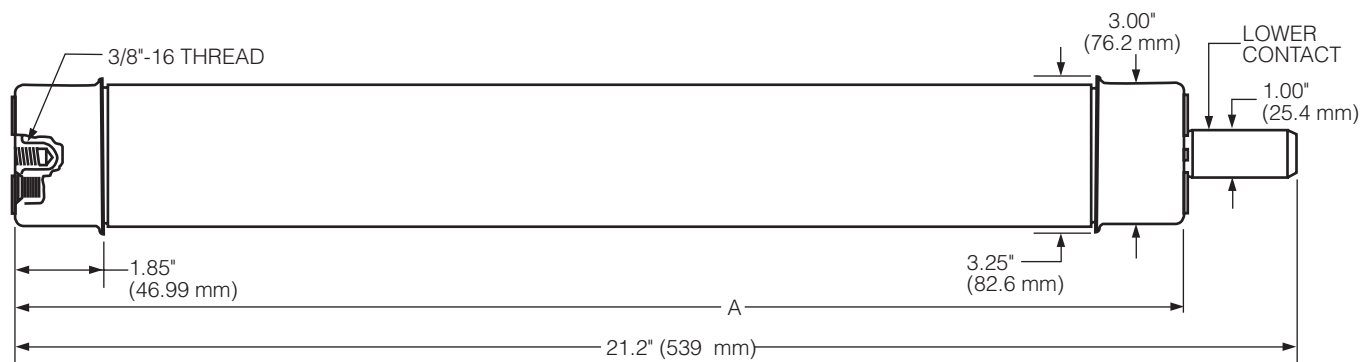

Figure 8. Dimensional information for E-rated 15.5 kV (65E-100E) version ELSG fuses

Note: Dimensions are given in Table 8.

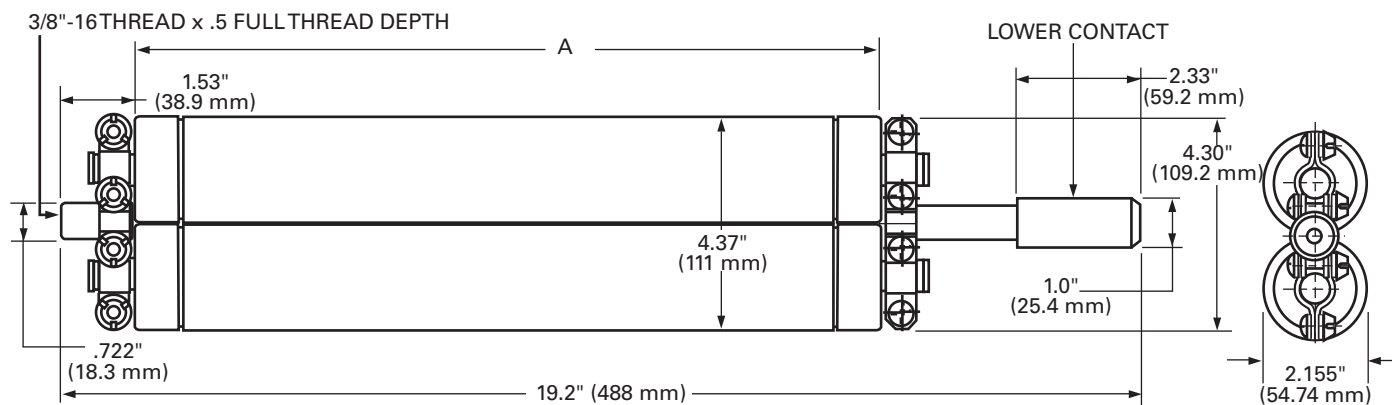

Figure 9. Dimensional information for E-rated 23 kV (50E, 65E) and 15.5 kV and 23 kV (90A) MSLE version ELSG fuses

Note: Dimensions are given in Table 8 and Table 9.

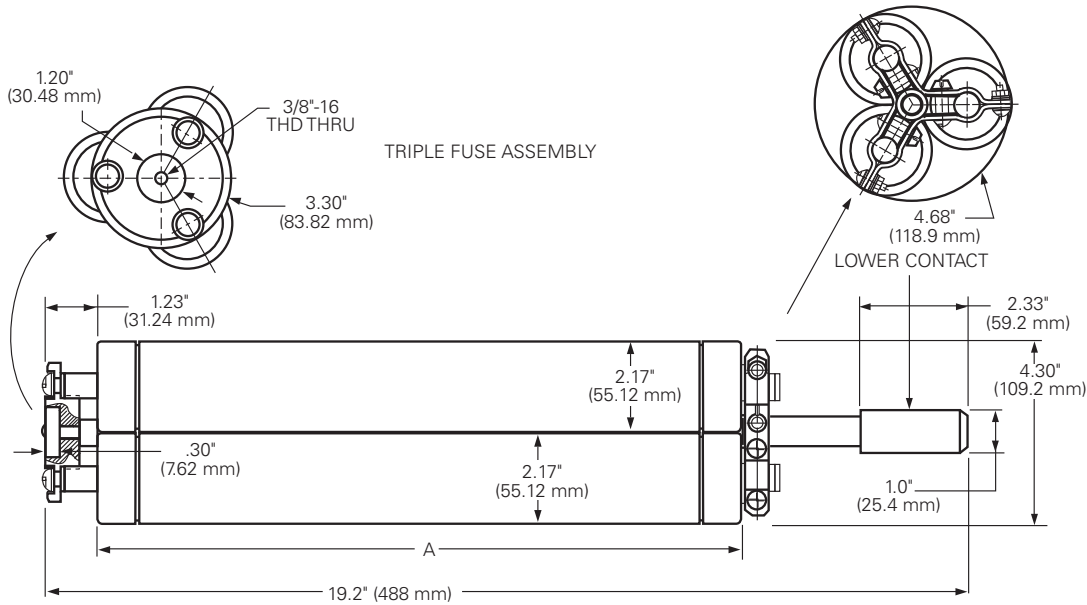

Figure 10. Dimensional information for E-rated 15.5 kV (150E) version ELSG fuses - 25 kV & 35 kV Wetwell Holder

Note: Dimensions are given in Table 8.

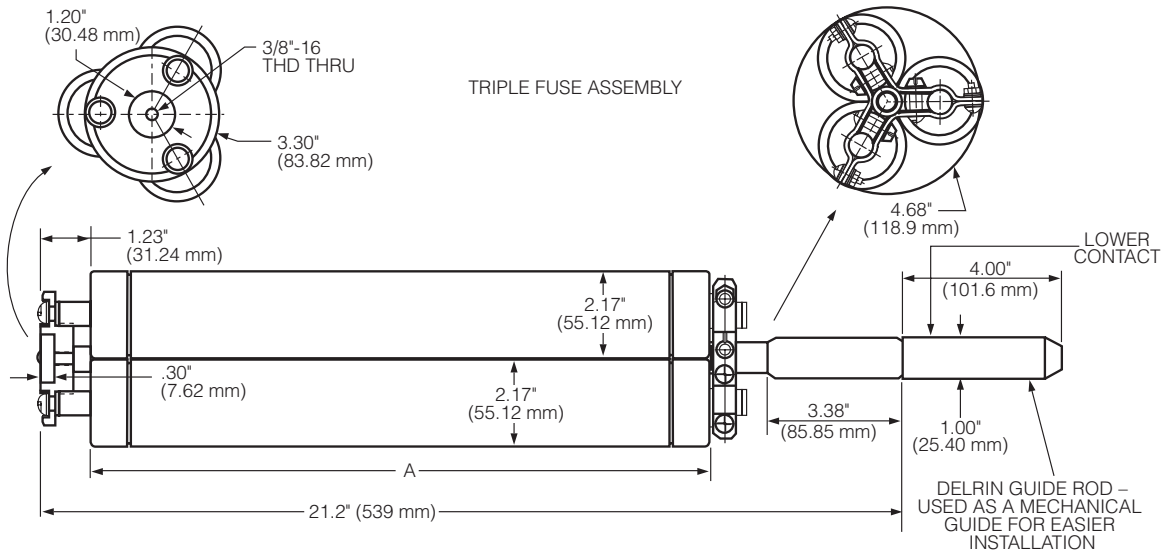

Figure 11. Dimensional information E-rated 23 kV (80E, 100E) and MSLE 23 kV (135A) version ELSG fuses

Note: Dimensions are given in Tables 8 and 9.

Application

Method A

Using the correlation tables

Use Table 10 to determine the amperage and voltage ratings of the E-rated ELSG fuse required for the application. Use Table 11 to determine the amperage and voltage ratings of the MSLE version ELSG fuses required for the application.

In the ordering information section, the fuse selection guides (Figures 12-14) can be used to determine applicable fuse catalog number.

Method B

Using time-current curves

To determine or confirm the ELSG fuse that will coordinate with upstream and downstream system requirements, use the time-current characteristic curves and specify the fuse indicated from Tables 12-15. For full size TCC curves, or other applications, contact your Eaton representative.

Table 10. Recommended E-rated fuses for switchgear (protection of three-phase transformer applications)

Three-phase Transformer kVA	8.3 kV				15.5 kV				23 kV											
	Nominal Three-phase voltage (kV) Phase-to-phase																			
	2.4		4.16		4.8		7.2-7.96		8.32		12.47		13.2-14.4		20.8		22.9-24.9 ^d		34.5 ^d	
	A	B	A	B	A	B	A	B	A	B	A	B	A	B	A	B	A	B	A	B
45	12	15	4	8	4	8	—	4	—	4	—	4	—	4	—	4 ^c	—	4 ^c	—	4 ^c
75	20	30	12	15	8	15	—	8	—	8	—	4	—	4	—	4 ^c	—	4 ^c	—	4 ^c
100	25	40	15	20	12	20	8	12	8	12	4	8	4	8 ^c	—	4 ^c	—	4 ^c	—	4 ^c
112.5	30	50	15	20	15	20	8	15	8	12	4	8	4	8	—	4	—	4 ^c	—	4 ^c
150	40	60	20	30	20	30	12	20	12	15	8	12	4 ^a	8	—	4	—	4	—	4 ^c
225	60 ^a	80	30	50	30	50	25	30	15	20	12	15	12	15	4	8	4	8	—	4
300	80	100	50	65	40	60	30	40	25	30	15	20	15	20	8	12	8	12	—	8
500	125	—	80	100	65	100	50	65	40	60	25	40	25	30	15	20	15	20	8	12
750	—	—	100	—	100	—	80	100	60	80	40	60	40	60	25	30	25	30	15	20
1000	—	—	125 ^a	—	125	—	100	125	80	100	50 ^a	65	50	65	30	50 ^c	30	40	20	25
1500	—	—	—	—	—	—	125	—	100	—	80	100	80	100	—	50	40 ^a	50	30	40
2000	—	—	—	—	—	—	—	—	125 ^a	—	100	150	100	150	50	65	50	65	40	50
2500	—	—	—	—	—	—	—	—	—	—	150	—	120	—	65	80	50 ^a	80	50 ^b	65
3000	—	—	—	—	—	—	—	—	—	—	150	—	150	—	65	100	65	100	50	65
3750	—	—	—	—	—	—	—	—	—	—	—	—	—	—	100	—	80	—	65	80
5000	—	—	—	—	—	—	—	—	—	—	—	—	—	—	—	—	100 ^a	—	80	100

Note: Recommendations are based on fuse melting characteristics at maximum oil temperature of 40 °C (typical switchgear application). Fuses have been derated 0.2% per degree C above 25 °C. Recommended fuses meet inrush criteria of 12 times transformer full load current for 0.1 second, and 25 times transformer full load current for 0.01 second.

Column A – Recommended fuse allows 140-200% loading.
 Column B – Recommended fuse allows 200-300% loading.

- a) Provides less than 140% loading.
- b) Provides more than 200% loading.
- c) Provides more than 300% loading.

d) Above 23 kV, Limited to gnd Y/gnd Y transformer with no more than 50% delta connected secondary load. (Phase-to-ground rated fuses are frequently recommended for Y-Y connections.)

Table 11. Recommended MSLE version ELSG fuses for switchgear (protection of three-phase transformer applications)

Three-phase Transformer kVA	8.3 kV				15.5 kV				23 kV											
	Nominal three-phase voltage (kV) Phase-to-phase																			
	2.4		4.16		4.8		7.2-7.96		8.32		12.47		13.2-14.4		20.8		22.9-24.9 ^d		34.5 ^d	
	A	B	A	B	A	B	A	B	A	B	A	B	A	B	A	B	A	B	A	B
112.5	50	90 ^c	—	—	—	—	—	—	—	—	—	—	—	—	—	—	—	—	—	—
150	50 ^a	90	—	50	—	50	—	—	—	—	—	—	—	—	—	—	—	—	—	—
225	90	—	50	90	50	90 ^c	—	50	—	50 ^c	—	—	—	—	—	—	—	—	—	—
300	—	—	—	90	50 ^a	90	—	50	—	50	—	50 ^c	—	—	—	—	—	—	—	—
500	—	—	—	—	90	—	—	90	50	90	—	50	—	50	—	—	—	—	—	—
750	—	—	—	—	—	—	90	—	90	—	50	90	50	90	—	50	—	50	—	—
1000	—	—	—	—	—	—	—	—	—	—	90	—	90	—	50	90 ^c	50	50	—	50
1500	—	—	—	—	—	—	—	—	—	—	—	—	—	90 ^a	—	—	90	50 ^a	90	50
2000	—	—	—	—	—	—	—	—	—	—	—	—	—	—	—	90	90	135	50	90
2500	—	—	—	—	—	—	—	—	—	—	—	—	—	—	135	—	90 ^a	135	90 ^b	90
3000	—	—	—	—	—	—	—	—	—	—	—	—	—	—	135	—	135	—	90	135
3750	—	—	—	—	—	—	—	—	—	—	—	—	—	—	135 ^a	—	135 ^a	—	90 ^a	135
5000	—	—	—	—	—	—	—	—	—	—	—	—	—	—	—	—	—	—	135	—

Note: Recommendations are based on fuse melting characteristics at maximum oil temperature of 40 °C (typical switchgear application). Fuses have been derated 0.2% per degree C above 25 °C. Recommended fuses meet inrush criteria of 12 times transformer full load current for 0.1 second, and 25 times transformer full load current for 0.01 second.

Column A – Recommended fuse allows 140-200% loading.
 Column B – Recommended fuse allows 200-300% loading.

- a) Provides less than 140% loading.
- b) Provides more than 200% loading.
- c) Provides more than 300% loading.

d) Above 23 kV, Limited to gnd Y/gnd Y transformer with no more than 50% delta connected secondary load. (Phase-to-ground rated fuses are frequently recommended for Y-Y connections.)

Ordering information

15 kV switchgear

Step 1.

To order an E-rated ELSG current-limiting fuse, determine the appropriate voltage and current ratings from the Application Section (refer to Table 10).

To order the MSLE version ELSG fuse, determine the appropriate voltage and continuous current ratings from the Application Section (refer to Table 11) or specify the appropriate catalog number in Table 4 by cross referencing an equivalent K-MATE[®] SL fuse.

Step 2.

Use the appropriate Fuse Selection Guide (refer to Figure 12) to find the applicable ELSG catalog numbers.

Step 3.

Select the appropriate ELSG catalog number from Tables 12 or 13.

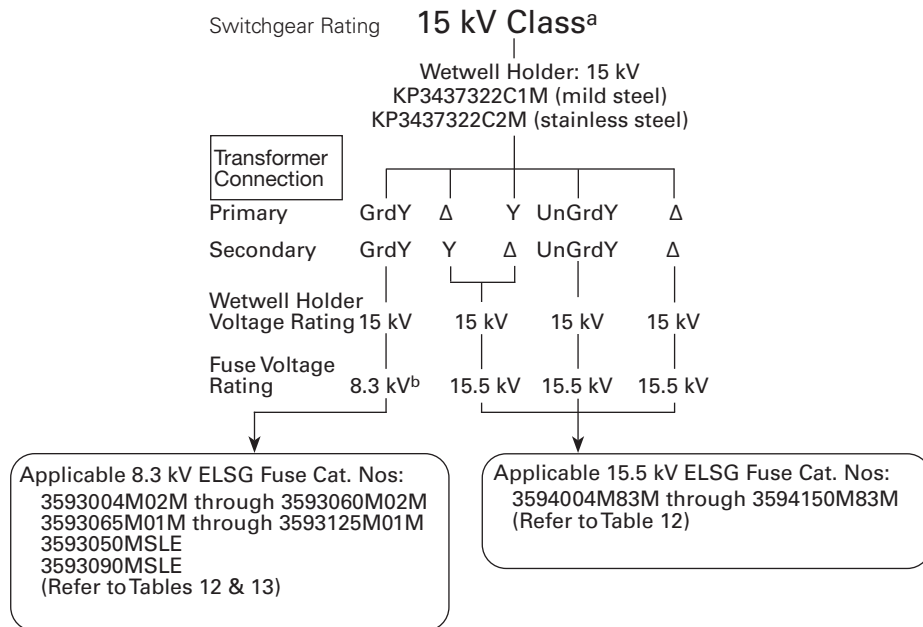

Notes:

^a The wetwell holder selections represent standard designs, special switchgear configurations may be possible. Consult your Eaton representative.

^b Limited to GrdY/GrdY transformer with no more than 50% Delta and/or UnGrdY connected secondary load.

Figure 12 Fuse selection guide for 15 kV class switchgear

Table 12. E-rated ELSG fuse ordering information for 15 kV Wetwell Holder*

E-Rating	Continuous Current rating (A)	Fuse kV and Catalog number	
		8.3 kV	15.5 kV
4	9	3593004M02M	3594004M83M
8	14	3593008M02M	3594008M83M
12	18	3593012M02M	3594012M83M
15	24	3593015M02M	3594015M83M
20	34	3593020M02M	3594020M83M
25	35	3593025M02M	3594025M83M
30	46	3593030M02M	3594030M83M
40	53	3593040M02M	3594040M83M
50	65	3593050M02M	3594050M83M
60	76	3593060M02M	3594060M83M
65	92	–	3594065M83M
65	95	3593065M01M	–
80	106	–	3594080M83M
80	125	3593080M01M	–
100	130	–	3594100M83M
100	155	3593100M01M	–
120	150	–	3594120M83M
125	180	3593125M01M	–
150	200	–	3594150M83M

* 15 kV Wetwell Holder part numbers KP3437322C1M (mild steel) and KP3437322C2M (stainless steel)

Table 13. MSLE version ELSG fuse ordering information for 15 kV Wetwell Holder*

Voltage rating (kV)	Continuous current rating (A)	Catalog number
8.3	50	3593050MSLE
	90	3593090MSLE

* 15 kV Wetwell Holder part numbers KP3437322C1M (mild steel) and KP3437322C2M (stainless steel)

Ordering information (continued)

25 and 35 kV switchgear

Step 1.

To order an E-rated ELSG current-limiting fuse, determine the appropriate voltage and current ratings from the Application Section (refer to Table 10).

To order the MSLE version ELSG fuse, determine the appropriate voltage and continuous current ratings from the Application Section (refer to Table 11) or specify the appropriate catalog number in Table 4 by cross referencing an equivalent K-MATE® SL fuse.

Step 2.

Use the appropriate Fuse Selection Guide (refer to Figure 13 or 14) to find the applicable ELSG catalog numbers.

Step 3.

Select the appropriate ELSG catalog number from Tables 14 or 15.

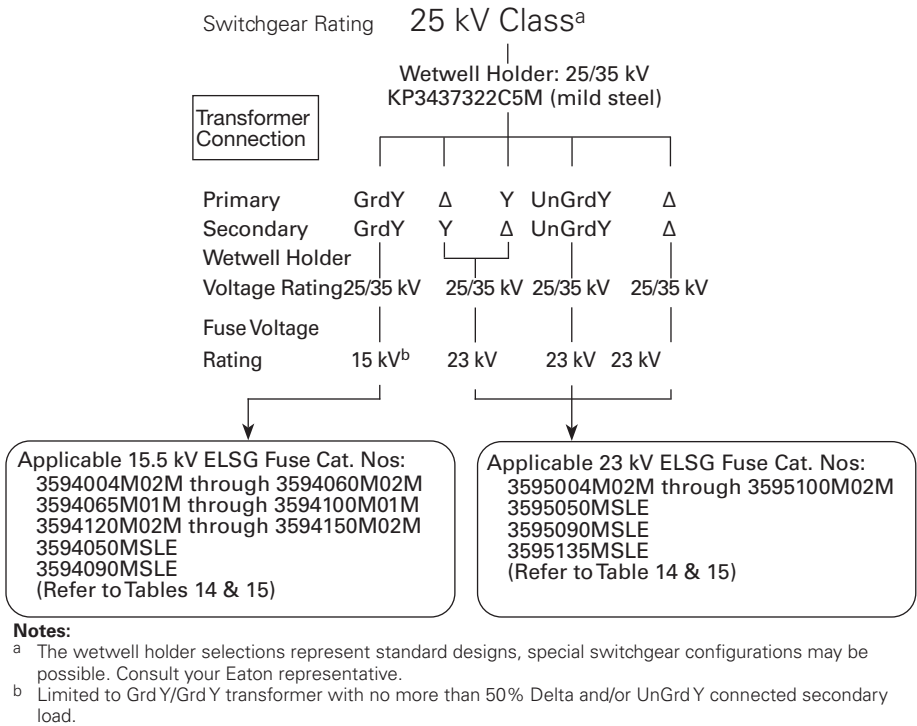

Figure 13. Fuse selection guide for 25 kv class switchgear

Additional information

Refer to the following reference literature for more information.

CA132019EN, ELSG Fuse Holder

MN132017EN, ELSG Full-range current-limiting fuse re-fusing instructions

CP-9132, ELSG Fuse certified test report

CP-9213, MSLE Version ELSG Fuse certified test report

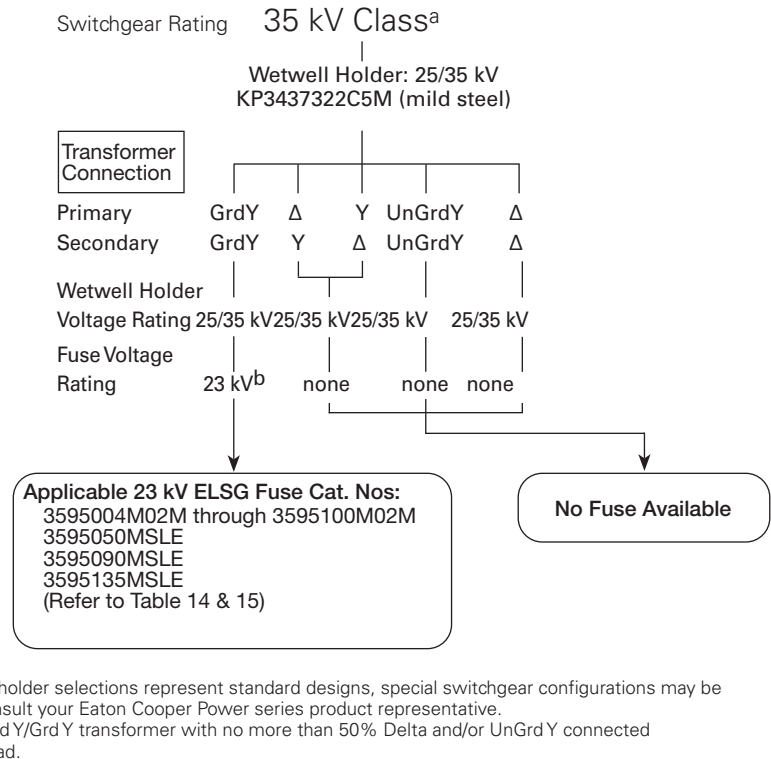

Figure 14. Fuse selection guide for 35 kV class switchgear

Table 14. E-rated ELSG fuse ordering information for 25 & 35 kV Wetwell Holder*

E-Rating	Continuous current rating (A)	Fuse kV and Catalog number	
		15.5 kV	23.0 kV
4	9	3594004M02M	3595004M02M
8	14	3594008M02M	3595008M02M
12	18	3594012M02M	3595012M02M
15	24	3594015M02M	3595015M02M
20	34	3594020M02M	3595020M02M
25	35	3594025M02M	3595025M02M
30	46	3594030M02M	3595030M02M
40	53	3594040M02M	3595040M02M
50	65	3594050M02M	–
50	96	–	3595050M02M
60	76	3594060M02M	–
65	95	3594065M01M	–
65	120	–	3595065M02M
80	125	3594080M01M	–
80	145	–	3595080M02M
100	140	3594100M01M	–
100	180	–	3595100M02M
120	150	3594120M02M	–
150	200	3594150M02M	–

* 25 & 35 kV Wetwell Holder part numbers KP3437322C5M (mild steel).

Table 15. MLSE version ELSG fuse ordering information for 25 & 35 kV Wetwell Holder*

Voltage rating (kV)	Continuous current rating (A)	Catalog number
15.5	50	3594050MSLE
	90	3594090MSLE
23	50	3595050MSLE
	90	3595090MSLE
	135	3595135MSLE

* 25 & 35 kV Wetwell Holder part numbers KP3437322C5M (mild steel).

Table 16. Shorting bar ordering information

Voltage rating (kV)	Continuous current rating (A)	Dimension A	Catalog number
15.5	200	19.0 (483 mm)	3437838B01
23	200	21.0 (533 mm)	3437838B02

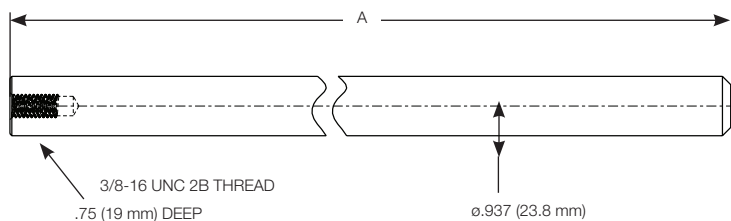

Figure 15. Dimensional Information for shorting bar

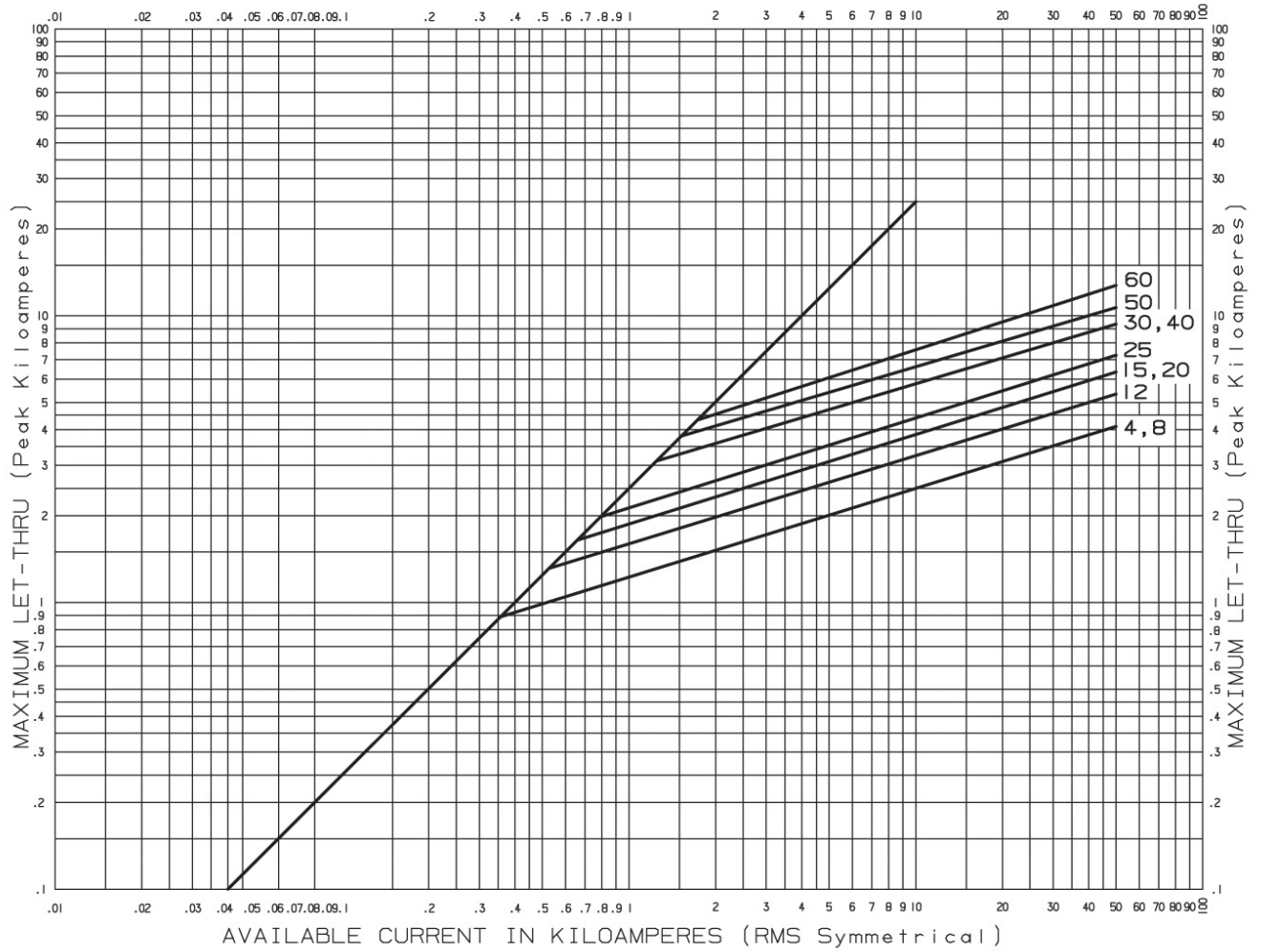

Figure 16. ELSG full-range under-oil 2.0 diameter current-limiting fuse peak let-thru curves

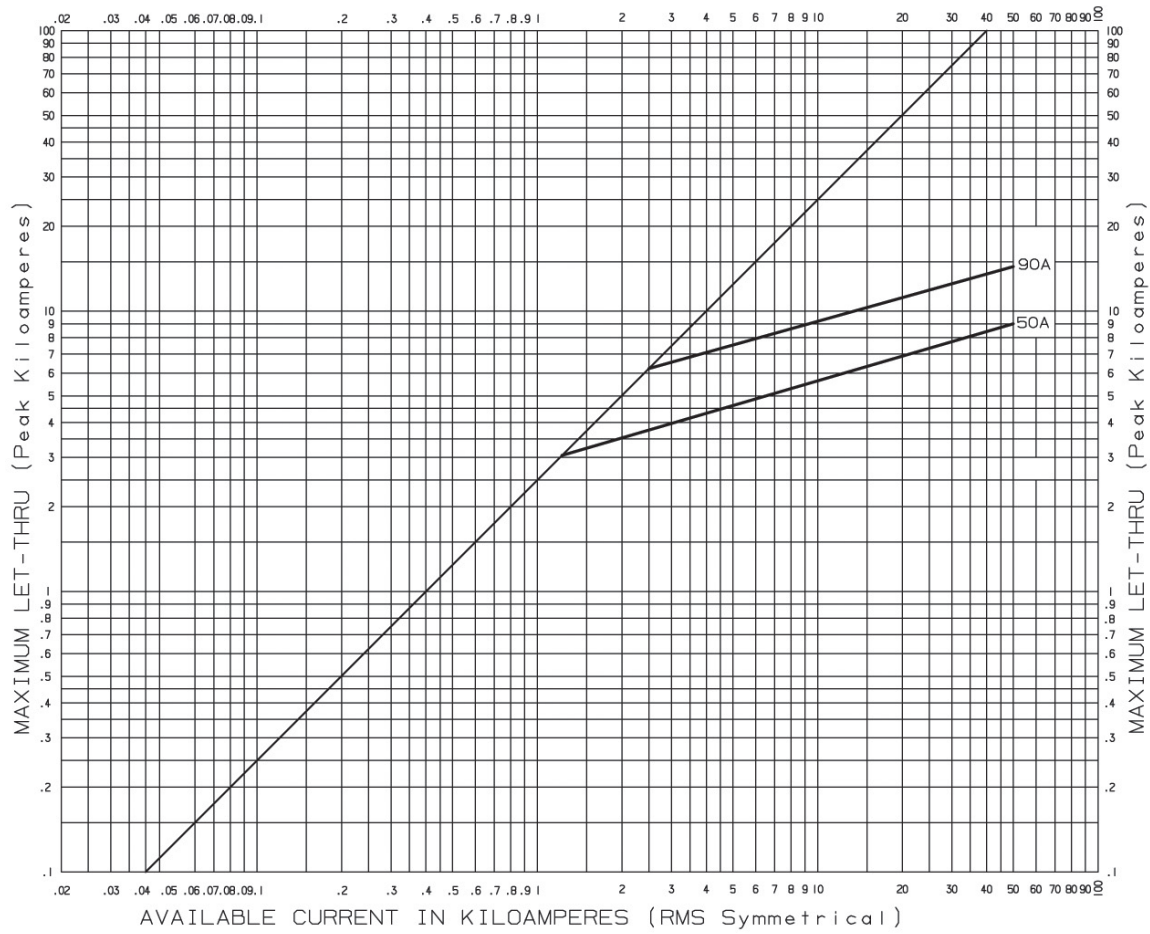

Figure 17. 8.3 kV and 15.5 kV ELSG full-range under-oil current-limiting fuse peak let-thru curves

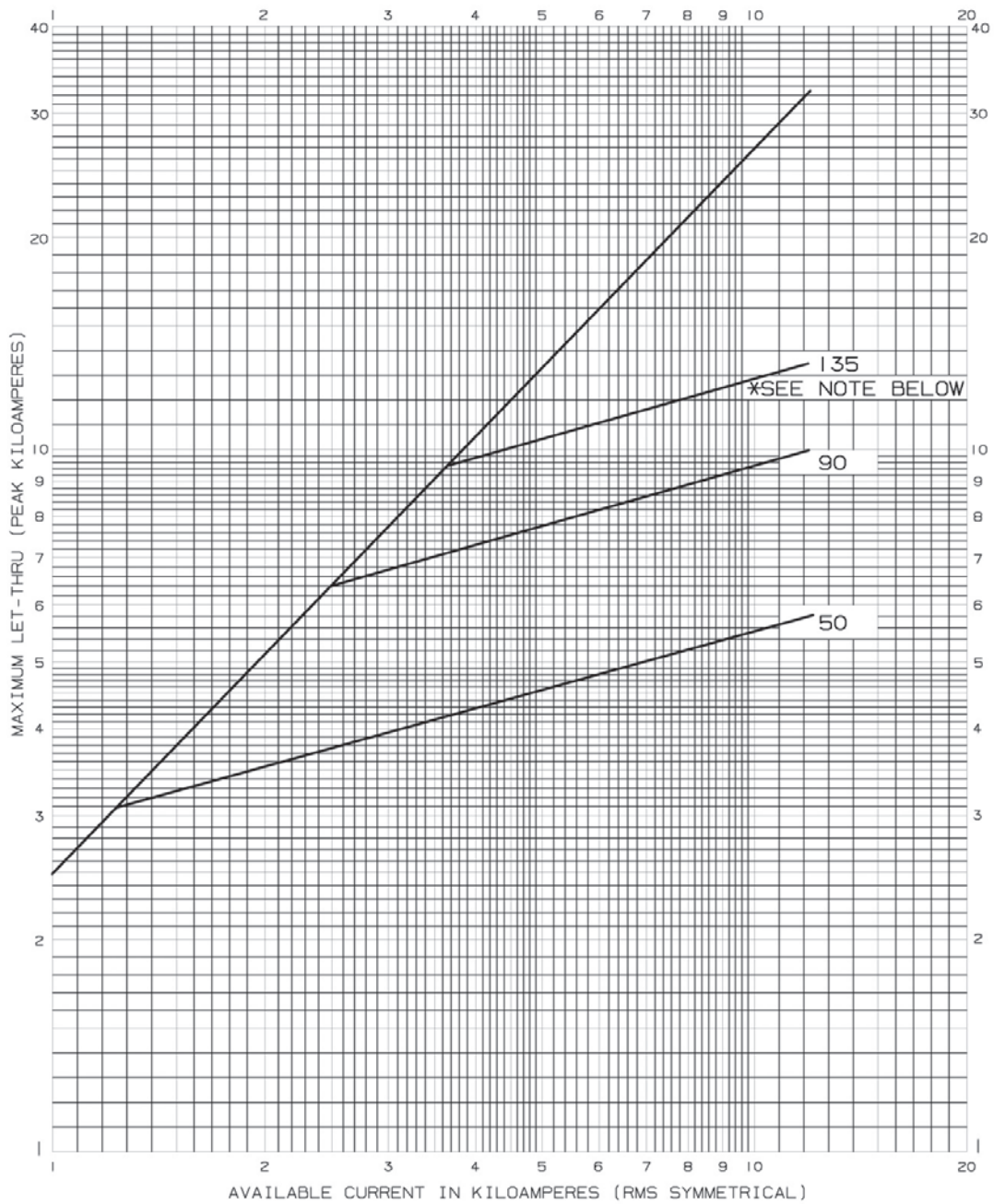

Figure 18. 8.3, 15.5 and 23 kV ELSG MLSE version full-range under-oil current-limiting fuse peak let-thru curves

* 135 A rating is only available at 23 kV.

Eaton
1000 Eaton Boulevard
Cleveland, OH 44122
United States
Eaton.com

Eaton's Power Systems Division
2300 Badger Drive
Waukesha, WI 53188
United States
Eaton.com/cooperpowerseries

© 2021 Eaton
All Rights Reserved
Publication No. CA132020EN
February 2021

Eaton is a registered trademark.
All other trademarks are property
of their respective owners.

For Eaton's Cooper Power series ELSG fuse
product information call
1-877-277-4636 or visit:
Eaton.com/cooperpowerseries