

UltraSIL Polymer-Insulated and Porcelain Type L Open Distribution Cutout



Contents

DESCRIPTION	2
INTERCHANGEABILITY	2
DESIGN FEATURES	2
APPLICATION	2
FUSEHOLDERS AND BLADES	3
100 A fuseholder	3
200 A fuseholder	3
300 A disconnect blade	3
CONNECTORS/BRACKETS	3
ELECTRICAL RATINGS	4
ORDERING INFORMATION	6
WILDLIFE GUARD	7
TYPE L FUSE CUTOUT/ARRESTER COMBINATION	8
CONSTRUCTION	8
DIMENSIONS	9
ORDERING INFORMATION	11
ADDITIONAL INFORMATION	12



Powering Business Worldwide

Description

Eaton has set a standard of excellence for polymer distribution cutouts with its Cooper Power™ series UltraSIL® polymer-insulated interchangeable cutouts. Our premium UltraSIL polymer-insulated cutout incorporates an industry recognized silicone rubber insulating material with superior hydrophobic qualities. Eaton offers Type L cutouts in both polymer and porcelain designs, which provide reliable overcurrent protection for primary distribution circuits. Overcurrent protection safeguards an electric system from excessive currents produced by abnormal conditions such as faults, line or equipment overloads, or equipment failures. Polymer and porcelain Type L cutouts are ruggedly constructed and will provide full-range overcurrent protection from minimum melt of a given fuse link to the maximum nameplate interrupting current rating of the cutout.

Polymer and porcelain Type L cutouts are available in 15.5 kV and 27 kV voltage ratings. Both polymer and porcelain Type L cutouts are available with a 100 A or 200 A fuseholder or with a 300 A disconnect blade.

UltraSIL polymer-insulated and porcelain Type L cutouts have been tested to, and meet or exceed all requirements set forth by IEEE Std C37.41-2008 and IEEE Std C37.42™-2009.

Interchangeability

The key for both polymer and porcelain Type L cutout designs is fuseholder interchangeability. Polymer and porcelain Type L cutouts eliminate the need to stock fuseholders from each manufacturer and are designed to be fuseholder interchangeable with polymer and porcelain cutouts manufactured by S & C Electric Co. (Type XS™), Hubbell Power Company (Type C™) and ABB (Type ICX™).

Fuseholder interchangeability reduces the time required to re-fuse a cutout during an outage by eliminating the need to determine which manufacturer's cutout is on the pole. Re-fusing of the spare fuseholder can be done even before the lineman leaves the truck. Interchangeability also significantly reduces inventory.

Design features

The backbone of the UltraSIL polymer-insulated Type L cutout is comprised of an E-glass fiberglass rod with crimped-on galvanized steel hanger and end fittings. The crimping process results in a robust design capable of withstanding numerous opening and closing operations and the severe forces present during fault current interruptions. The frame is over molded with the industry leading, track resistant, UltraSIL silicone rubber polymer-housing. Independent laboratory tests have verified the superiority of silicone rubber in terms of resistance to UV degradation, surface tracking/performance in contaminated environments, and other important insulating properties. The complete cutout assembly works together as a system and will stand up to years of exposure to environmental extremes.

The porcelain Type L cutout is designed with a solid core, birdproof, one-piece porcelain frame with uniform shed configuration. Sulfur cemented studs provide high strength connections.

The fuseholder is constructed of an epoxy impregnated glass filament wound tube over a moisture-proof inner polymer liner material. A large bronze cast pull ring is utilized for ease

of installation and re-fusing. The bronze trunnion, with lifting ring having both front and side accessibility, is silver plated for minimum contact resistance. The grooved flipper assembly controls link tension, assures low-fault current interruption and prevents link breakage on "close-in."

The cast bronze lower hinge assembly has deep pockets for the trunnion to pivot to minimize accidental fuse removal. The rugged design with wide opening means easy fuseholder installation and removal. The lower contact assembly utilizes stainless steel backup springs and silver-to-silver contacts to minimize contact resistance and assure excellent continuous contact throughout the life of the cutout. The contacts are designed to carry 300 A continuous. Silver-to-silver top contacts are again used to minimize contact resistance. The Type L cutout design develops high contact pressure to assure excellent contact for operating currents and until fault interruption is completed.

Loadbreak hooks, for use with a loadbreak tool, are standard and serve as a "close-in" guide to assure positive make.

Lubricant is applied to all separable connector interchanges. All hardware is designed to interlock during assembly to assure correct alignment. The rugged design assures smooth operation and long life.

Application

Proper cutout application requires several major system considerations: system operating voltage, insulation level, type of system grounding, maximum available fault current the cutout may be subjected to, and anticipated maximum continuous load current.

The polymer and porcelain Type L cutout voltage rating is the maximum design voltage of the cutout. It can be applied, without restrictions, on any three-phase system that has system line-to-line voltage less than or equal to the cutout rating. Type L cutouts can also be applied on single-phase or three-phase solidly grounded wye connected circuits. The circuit can have line-to-neutral voltages up to the voltage rating of the cutout as long as the maximum recovery voltage does not exceed the cutout's rating.

The Basic Impulse Insulation Level (BIL) of a cutout should be coordinated with the insulation of other connected apparatus. The interrupting rating of a cutout should be greater than or equal to the maximum available system fault current unless used in conjunction with current-limiting fuses such as the Companion® II backup fuse or the ELF™ full-range fuse. The cutout selected should have a continuous current rating sufficient to handle the expected load. The 100 A rated fuseholder accepts fuse links from a fraction of 1 A to 100 A. The 200 A fuseholder will accept fuse links with ratings above 100 A to 200 A.

When selecting a cutout or fuse, it is important to consider future load growth and other planned system expansion.

Eaton offers full-range current-limiting fuses for applications where system fault current exceeds the maximum interrupting rating of an expulsion fuse. ELF full-range current-limiting fuses and Tandem ELF fuses are designed to be mounted directly to a polymer or porcelain Type L cutout, replacing the cutout expulsion fuseholder. The ELF fuse's versatile designs allow for safe capacitor protection and reduces the installation costs associated with bolted connections. See catalog sections CA132027EN and CA132028EN or consult your local Eaton representative for further information.

Fuseholders and blades

100 A fuseholder

The UltraSIL polymer-insulated and porcelain Type L cutouts accommodate standard IEEE® and NEMA® universal type fuse links. This fuseholder can handle universal links up to 100 A.

An arc shortening rod can be used to obtain the higher interrupting current ratings. The arc shortening rod is made of silver-plated, high-conductivity copper and is mechanically attached to the fuse cap. Removable buttonhead fuse links must be used with arc shortening rods.

The 100 A fuseholder features a spring assist which helps clear the fuseholder under low current operations. It also comes standard with a 9/16-inch bolt for easy leader installation.



Figure 1. 100 A fuseholder

200 A fuseholder

This fuseholder can handle universal links above 100 A up to 200 A and is fully rated for 15.5 kV or 27 kV voltage ratings.



Figure 2. 200 A fuseholder

The 200 A door comes standard with an arc shortening rod. The arc shortening rod is made of silver-plated, high-conductivity copper and is mechanically attached to the fuse cap.

Removable buttonhead fuse links must be used with arc shortening rods. The 200 A fuseholder features a spring assist which helps clear the fuseholder under lower current operations. It also comes standard with a 9/16-inch bolt and captive washer for easy leader installation and capturing.

300 A disconnect blade

UltraSIL polymer-insulated and porcelain Type L 300 A disconnect blades (refer to **Figure 3**) are constructed of a high-conductivity copper tube. 300 A fuse caps are threaded directly onto the copper tube, reducing the number of current interchanges on the blade to only two.



Figure 3. 300 A disconnect blade

Connectors/brackets

UltraSIL polymer-insulated and porcelain Type L cutouts include a tin-plated bronze parallel-groove connector as standard. The parallel-groove connector fits a conductor range of #8 solid (0.128-inch diameter) to 250 MCM (0.575-inch diameter). Tin-plated bronze eyebolt and large eyebolt connector options are also available. The eyebolt connector fits a conductor range of #8 solid (0.128-inch diameter) to 2/0 stranded (0.419-inch diameter) and the large eyebolt connector fits a conductor range of #6 solid (0.162-inch diameter) to 250 MCM (0.575-inch diameter).

UltraSIL polymer-insulated and porcelain Type L cutout crossarm mounting includes a heavy-duty NEMA Type B crossarm mounting bracket to withstand the mechanical forces generated during fault current interruptions when using an expulsion fuse link. An extended crossarm mounting bracket option is also available. Type L cutouts are also available without crossarm mounting brackets. See **Table 3** for all connector and bracket options.

Electrical ratings

Electrical insulation ratings for the polymer and porcelain Type L cutouts are shown in **Table 1**.

All cutouts have been tested in accordance with IEEE Std C37.40™-2003, IEEE Std C37.41-2008 and IEEE Std C37.42™-2009.

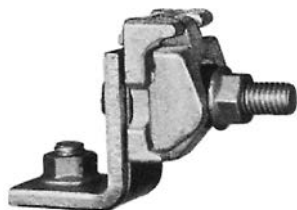

Figure 4. Parallel-groove connector



Figure 5. Eyebolt connector



Figure 6. Additional arrester mounting hardware (bagged) included for options 5 and 6

Table 1. 15 and 27 kV polymer and porcelain Type L interchangeable cutout specifications

Base catalog number ①		Maximum voltage rating (kV)	BIL (kV)	Continuous current (A)	Interrupting rating (A rms)		Creep distance inches (mm)		Approximate weight lb (kg)	
Polymer	Porcelain				Symmetrical	Asymmetrical	Polymer	Porcelain	Polymer	Porcelain
S4B1	L4B1	15.5	110	100	7,100	10,000	14.2 (362)	8.5 (216)	8.2 (3.7)	14.5 (6.5)
S4BA ②	L4BA ②	15.5	110	100	10,600	16,000	14.2 (362)	8.5 (216)	8.3 (3.8)	14.6 (6.6)
S4B2 ②	L4B2 ②	15.5	110	200	8,000	12,000	13.8 (350.52)	8.5 (216)	8.7 (3.9)	15.0 (6.8)
S4B3	L4B3	15.5	110	300	Disconnect ③	Disconnect ③	14.2 (362)	8.5 (216)	7.7 (3.5)	14.0 (6.4)
	L9C1	27	125	100	5,300	8,000		11.0 (279)		16.7 (7.5)
	L9CA ②	27	125	100	8,000	12,000		11.0 (279)		16.8 (7.6)
	L9C2 ②	27	125	200	7,100	10,000		11.0 (279)		17.2 (7.8)
	L9C3	27	125	300	Disconnect ③	Disconnect ③		11.0 (279)		16.2 (7.3)
S9D1	L9D1	27	150	100	5,300	8,000	24.4 (619.76)	17.0 (432)	10.2 (4.6)	22.5 (10.2)
S9DA ②	L9DA ②	27	150	100	8,000	12,000	24.4 (619.76)	17.0 (432)	10.3 (4.7)	22.6 (10.3)
S9D2 ②	L9D2 ②	27	150	200	7,100	10,000	24.4 (619.76)	17.0 (432)	10.7 (4.9)	23.0 (10.4)
S9D3	L9D3	27	150	300	Disconnect ③	Disconnect ③	24.4 (619.76)	17.0 (432)	9.7 (4.4)	22.0 (10.0)

① Base catalog number for standard polymer-insulated and porcelain Type L unit. See **Table 3** for optional connectors and brackets.

② These units include an arc shortening rod and must be used with removable buttonhead fuse links.

③ 300 A disconnect short-time current ratings: 12 kA (asym) momentary, 8.6 kA (sym) 15-cycle and 1.6 kA 3 sec.

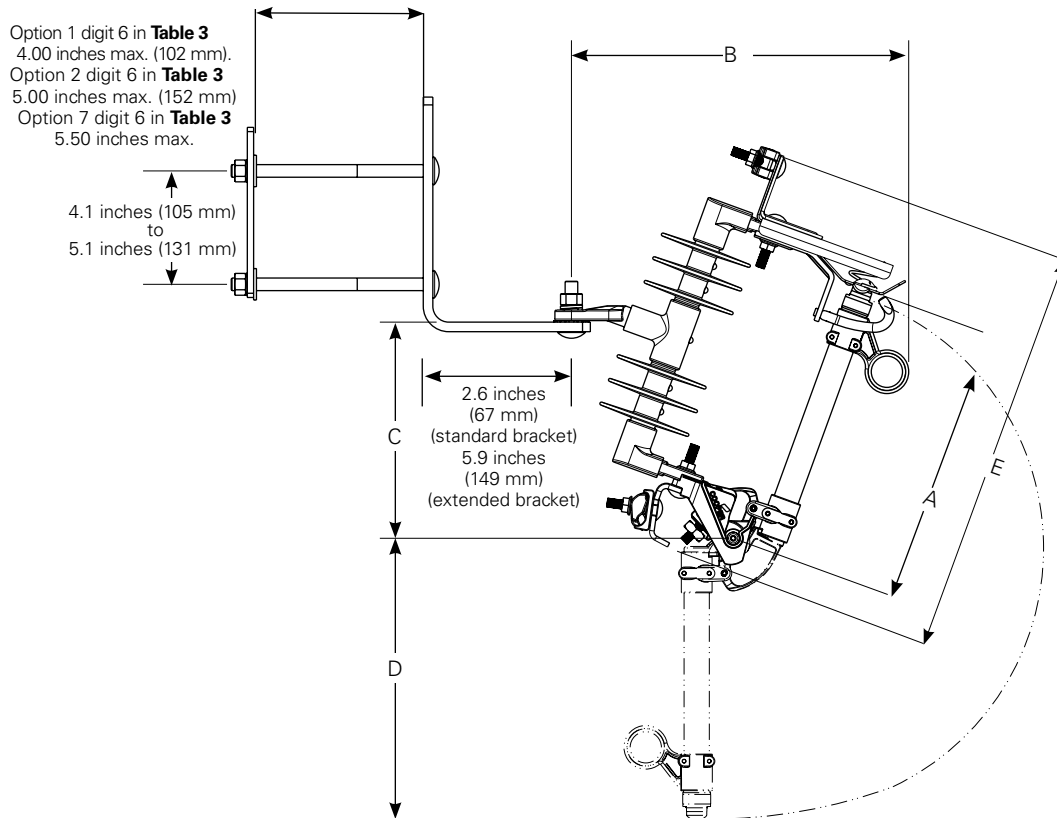

Figure 7. Polymer-insulated Type L cutout assembly shown. Dimensions apply to both polymer-insulated and porcelain Type L cutouts

Table 2. Polymer-insulated and porcelain Type L cutouts dimensional data (refer to Figure 7)

Voltage rating kV	BIL kV	Dimensions inches (mm)					Creepage distance inches (mm)	
		A	B	C	D	E	Polymer	Porcelain
15.5	110	11.3 (288)	13.5 (343)	8.1 (207)	11.5 (292)	16.3 (414)	13.8 (350.52)	8.5 (216)
27	125 ①	14.7 (374)	14.0 (358)	10.1 (257)	14.9 (379)	19.6 (498)	—	11.0 (279)
	150		14.2 (363)				24.4 (619.76)	17.0 (432)

① Electrical and dimensional information applies to porcelain cutouts only.

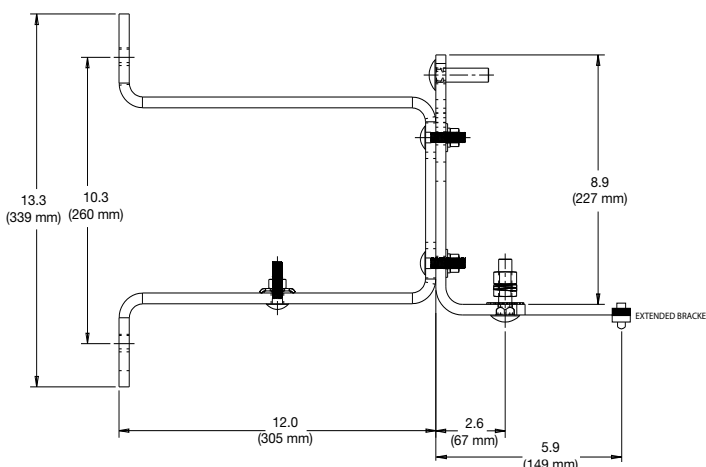

Figure 8. NEMA "D" pole mounting bracket (option 8) and extended bracket (option 4) in Table 3, digit 6

Ordering information

To order a complete Type L cutout with a fuseholder or disconnect blade, choose the appropriate part number from **Table 3**.

To order an individual fuseholder, disconnect blade, or the cutout mounting frame, refer to **Table 4** or **Table 5**.

Table 3. Polymer-insulated and porcelain Type L cutout combination numbering system

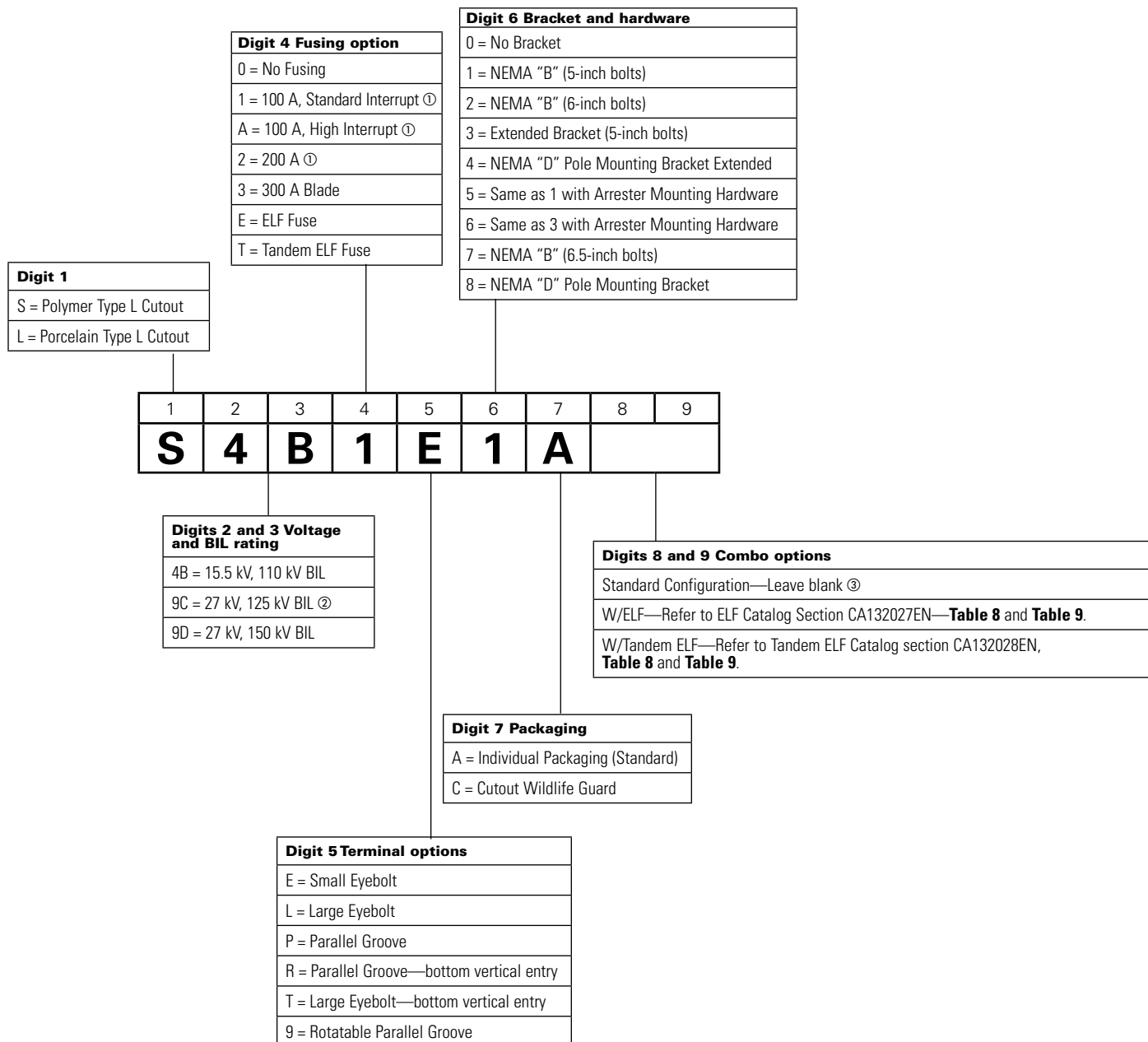

① See **Table 1** for interrupting rating based on cutout frame.

② Porcelain only.

③ If E or T is selected for Digit 4, digits for 8 and 9 must be selected. Refer to ELF fuse Catalog section CA132027EN for further detail. Refer to Tandem ELF fuse catalog section CA132028EN for further detail.

Table 4. Polymer-insulated and porcelain Type L fuseholders, disconnect blades, and replacement caps

Catalog number	Maximum design voltage kV	Continuous current A-rms	Interrupting rating A-rms asym	Approximate fuseholder length inches (mm)	Approximate weight lb (kg)	Replacement caps
For 15.5 kV, 110 kV BIL cutouts						
LDB100A	15.5	100	10,000	11.32 (288)	1.9 (0.86)	LDB100CAP
LDBA00A ①		100	16,000		2.0 (0.91)	LDBA00CAP
LDB200B ①		200	12,000		2.4 (1.1)	LDB20BCAP
LDB300A		300	Disconnect ②		1.4 (0.64)	LC12X1
For 27 kV, 125 kV BIL cutouts						
LDC100A	27	100	8,000	14.74 (374)	2.1 (0.95)	LDB100CAP
LDCA00A ①		100	12,000		2.2 (1.0)	LDCA00CAP
LDC200B ①		200	10,000		2.6 (1.2)	LDC20BCAP
LDC300A		300	Disconnect ②		1.6 (0.73)	LC12X1
For 27 kV, 150 kV BIL cutouts						
LDC100A	27	100	8,000	14.74 (374)	2.1 (0.95)	LDB100CAP
LDCA00A ①		100	12,000		2.2 (1.0)	LDCA00CAP
LDC200B ①		200	10,000		2.6 (1.2)	LDC20BCAP
LDC300A		300	Disconnect ②		1.6 (0.73)	LC12X1

① These fuseholders include an arc shortening rod and must be used with removable buttonhead fuse links.
② 300 A disconnect short time current ratings: 12 kA (Asym) momentary, 8.6 kA (Sym) 15-Cycle and 1.6 kA 3 sec.

Table 5. Polymer-insulated and porcelain Type L open cutout mounting frames only (without fuseholder or disconnect blade)

Base catalog number ① Type L cutout		Maximum design voltage (kV)	BIL (kV)	Creepage distance inches (mm)		Approximate weight lb (kg)	
Polymer	Porcelain			Polymer	Porcelain	Polymer	Porcelain
S4B0	L4B0	15.5	110	13.8 (350.52)	8.5 (216)	6.6 (3.0)	12.6 (5.7)
—	L9C0	27	125 ②	—	11.0 (279)	—	14.6 (6.6)
S9D0	L9D0		150	24.4 (619.76)	17.0 (432)	10.3 (4.7)	20.4 (9.3)

① See **Table 3** for optional connectors and brackets.
② Electrical and dimensional information applies to 27 kV 125 kV BIL porcelain Type L cutouts only.

Wildlife guard

The UV and track-resistant polymer wildlife guard provides superior protection against accidental contact outages by animals and debris. It fits both porcelain and polymer models, 15 and 27 kV ratings.

Table 6. Electrical characteristics and dimensions for cutout wildlife guard

Wildlife guard	Voltage rating (kV)	BIL rating (kV)	Dimensions inches (mm)			Top skirt diameter inches (mm)		Weight lb (kg)
			Length	Width	Height	Min.	Max.	
400051072C	15, 27	95–150	12.25 (311)	5 (127)	7 (178)	2.5 (64)	3.6 (92)	1.3 (.6)



Figure 9. 400051072C cutout wildlife guard

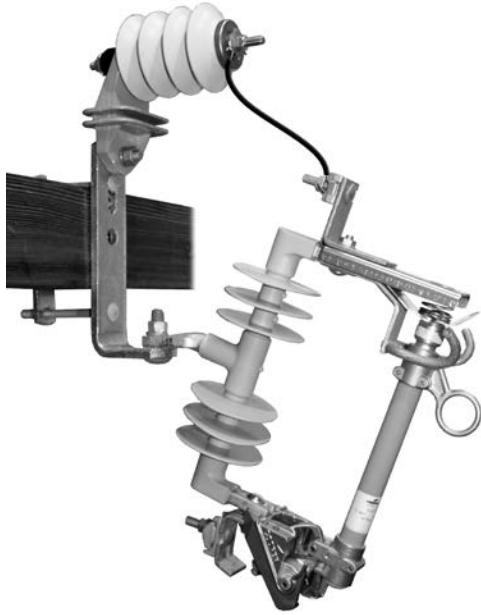

Figure 10. Fuse cutout/arrester combination

Type L fuse cutout/arrester combination

Eaton's Cooper Power series Type L interchangeable fuse cutout/arrester combinations are available in a wide variety of both arrester and fuse cutout designs. Surge arresters are available in silicone rubber in heavy-duty, normal-duty, or heavy-duty riser pole classifications in ratings 3–36 kV. Type L fuse cutouts are available with silicone rubber (UltraSIL polymer-insulated) or porcelain insulators for both 15 kV and 27 kV voltage ratings.

Cutouts are available with a 100 A or 200 A fuseholder or with a 300 A disconnect blade. Type L cutouts will also accommodate Eaton's Cooper Power series ELF full-range current-limiting fuse and Tandem ELF backup fuse with series fuse link.

Combining the functions of a distribution-class surge arrester with a fuse cutout provides the convenience of a compact, efficient unit with less pole-top hardware. Combining these units also provides easier installation, handling, and procurement.

All surge arresters used in Type L fuse cutout/arrester combinations have been tested to, and meet or exceed, all requirements of IEEE Std C62.11™-2005, "IEEE Standard for Metal-Oxide Surge Arresters for Alternating Current Power Circuits."

UltraSIL polymer-insulated and porcelain Type L cutouts have been tested to, and meet or exceed, all requirements set forth by the latest revisions of IEEE Std C37.41-2008 and IEEE Std C37.42™-2009.

Construction

The Type L fuse cutout/arrester combination comes complete with a crossarm mounting bracket for application on the utility pole crossarm. Standard arrester line and ground terminal hardware includes a silicon bronze nut, a stainless steel wire clamp and a line lead. The arrester line and ground terminal fits a conductor range of #6 (0.184-inch diameter) to 2/0 standard (0.418-inch diameter).

Dimensions

Figure 11 shows an outline drawing of an UltraSIL polymer-housed surge arrester/porcelain Type L fuse cutout/arrester combination. **Figure 12** shows an outline drawing of an UltraSIL polymer-housed surge arrester/ UltraSIL polymer-insulated Type L fuse cutout/arrester combination.

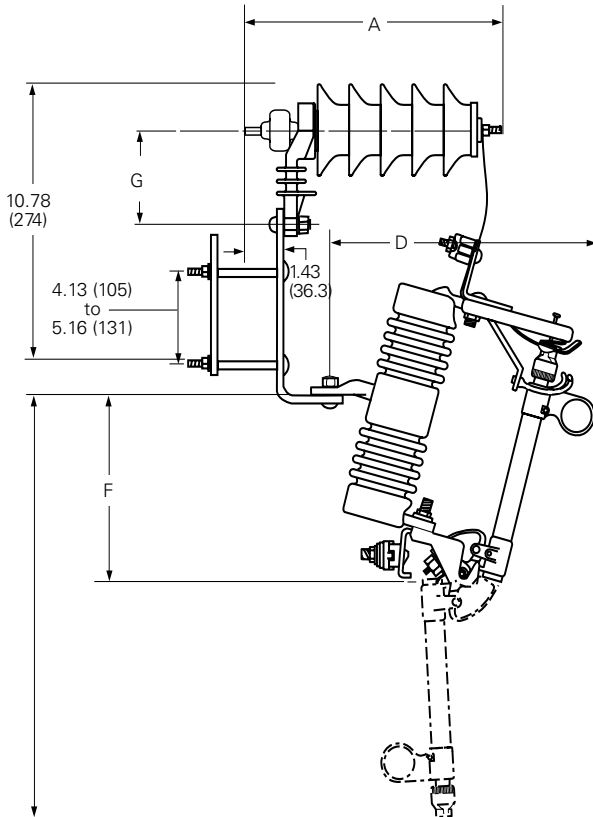

Figure 11. UltraSIL polymer-housed surge arrester/porcelain Type L fuse cutout/arrester combination—dimensions in inches (mm)

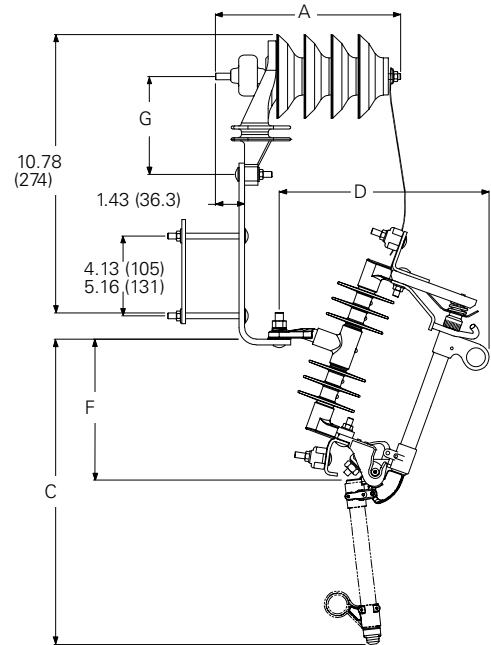

Figure 12. UltraSIL polymer-housed surge arrester/ UltraSIL polymer-insulated Type L fuse cutout/arrester combination— dimensions in inches (mm)

Table 7. UltraSIL polymer-housed / 15 kV UltraSIL polymer-insulated or porcelain Type L fuse cutout/arrester combination dimensional data

Arrester rating kV	A UltraSIL polymer-housed arrester		C UltraSIL polymer-insulated and porcelain Type L cutout inches (mm) ①	D UltraSIL polymer-insulated and porcelain Type L cutout inches (mm) ①	F UltraSIL polymer-insulated and porcelain Type L cutout inches (mm) ①	G UltraSIL polymer-insulated and porcelain Type L cutout inches (mm) ①
	VariSTAR® inches (mm) ①	Evolution inches (mm) ①				
3	6.9 (175)	7.9 (201)	19.68 (500)	13.5 (343)	8.18 (208)	4.12 (105)
6	7.9 (201)	9.0 (229)	19.68 (500)	13.5 (343)	8.18 (208)	4.12 (105)
9	9.0 (229)	9.0 (229)	19.68 (500)	13.5 (343)	8.18 (208)	4.12 (105)
10	9.0 (229)	9.0 (229)	19.68 (500)	13.5 (343)	8.18 (208)	4.12 (105)
12	10.0 (254)	11.1 (282)	19.68 (500)	13.5 (343)	8.18 (208)	5.17 (131)
15	11.1 (282)	11.1 (282)	19.68 (500)	13.5 (343)	8.18 (208)	5.17 (131)
18	12.2 (310)	12.2 (310)	19.68 (500)	13.5 (343)	8.18 (208)	5.17 (131)
21	13.2 (336)	13.2 (336)	19.68 (500)	13.5 (343)	8.18 (208)	5.17 (131)
24	14.3 (363)	14.3 (363)	19.68 (500)	13.5 (343)	8.18 (208)	5.17 (131)
27	15.3 (389)	15.3 (389)	19.68 (500)	13.5 (343)	8.18 (208)	5.17 (131)
30	16.4 (417)	16.4 (417)	19.68 (500)	13.5 (343)	8.18 (208)	5.17 (131)
36	18.5 (470)	18.5 (470)	19.68 (500)	13.5 (343)	8.18 (208)	5.17 (131)

① Refer to Figure 11.

② Dimensions pertain to normal-duty, heavy-duty, and heavy-duty riser pole VariSTAR porcelain arresters.

Table 8. UltraSIL polymer-housed surge arrester / 27 kV UltraSIL polymer-insulated or porcelain Type L fuse cutout/arrester combination dimensional data

Arrester rating kV	A UltraSIL polymer-housed arrester		C UltraSIL polymer-insulated and porcelain Type L ③ cutout inches (mm) ①	D UltraSIL polymer-insulated and porcelain Type L ③ cutout inches (mm) ①	F UltraSIL polymer-insulated and porcelain Type L ③ cutout inches (mm) ①	G UltraSIL polymer-insulated and porcelain Type L ③ cutout inches (mm) ①
	VariSTAR inches (mm) ①	Evolution inches (mm) ①				
3	6.9 (175)	7.9 (201)	25.04 (636)	14.09 (358)	10.12 (257)	4.12 (105)
6	7.9 (201)	9.0 (229)	25.04 (636)	14.09 (358)	10.12 (257)	4.12 (105)
9	9.0 (229)	9.0 (229)	25.04 (636)	14.09 (358)	10.12 (257)	4.12 (105)
10	9.0 (229)	9.0 (229)	25.04 (636)	14.09 (358)	10.12 (257)	4.12 (105)
12	10.0 (254)	11.1 (282)	25.04 (636)	14.09 (358)	10.12 (257)	5.17 (131)
15	11.1 (282)	11.1 (282)	25.04 (636)	14.09 (358)	10.12 (257)	5.17 (131)
18	12.2 (310)	12.2 (310)	25.04 (636)	14.09 (358)	10.12 (257)	5.17 (131)
21	13.2 (336)	13.2 (336)	25.04 (636)	14.09 (358)	10.12 (257)	5.17 (131)
24	14.3 (363)	14.3 (363)	25.04 (636)	14.09 (358)	10.12 (257)	5.17 (131)
27	15.3 (389)	15.3 (389)	25.04 (636)	14.09 (358)	10.12 (257)	5.17 (131)
30	16.4 (417)	16.4 (417)	25.04 (636)	14.09 (358)	10.12 (257)	5.17 (131)
36	18.5 (470)	18.5 (470)	25.04 (636)	14.09 (358)	10.12 (257)	5.17 (131)

① Refer to Figure 12.

② Dimensions pertain to normal-duty, heavy-duty, and heavy-duty riser pole VariSTAR porcelain arresters.

③ Dimensions pertain to 27 kV, 150 kV BIL UltraSIL polymer-insulated cutouts and 27 kV, 125 kV, and 150 kV porcelain cutouts.

Ordering information

To order cutout/arrester combinations complete the appropriate catalog number shown in **Table 9**.

Table 9. UltraSIL polymer-insulated and porcelain Type L cutout/arrester combination numbering system

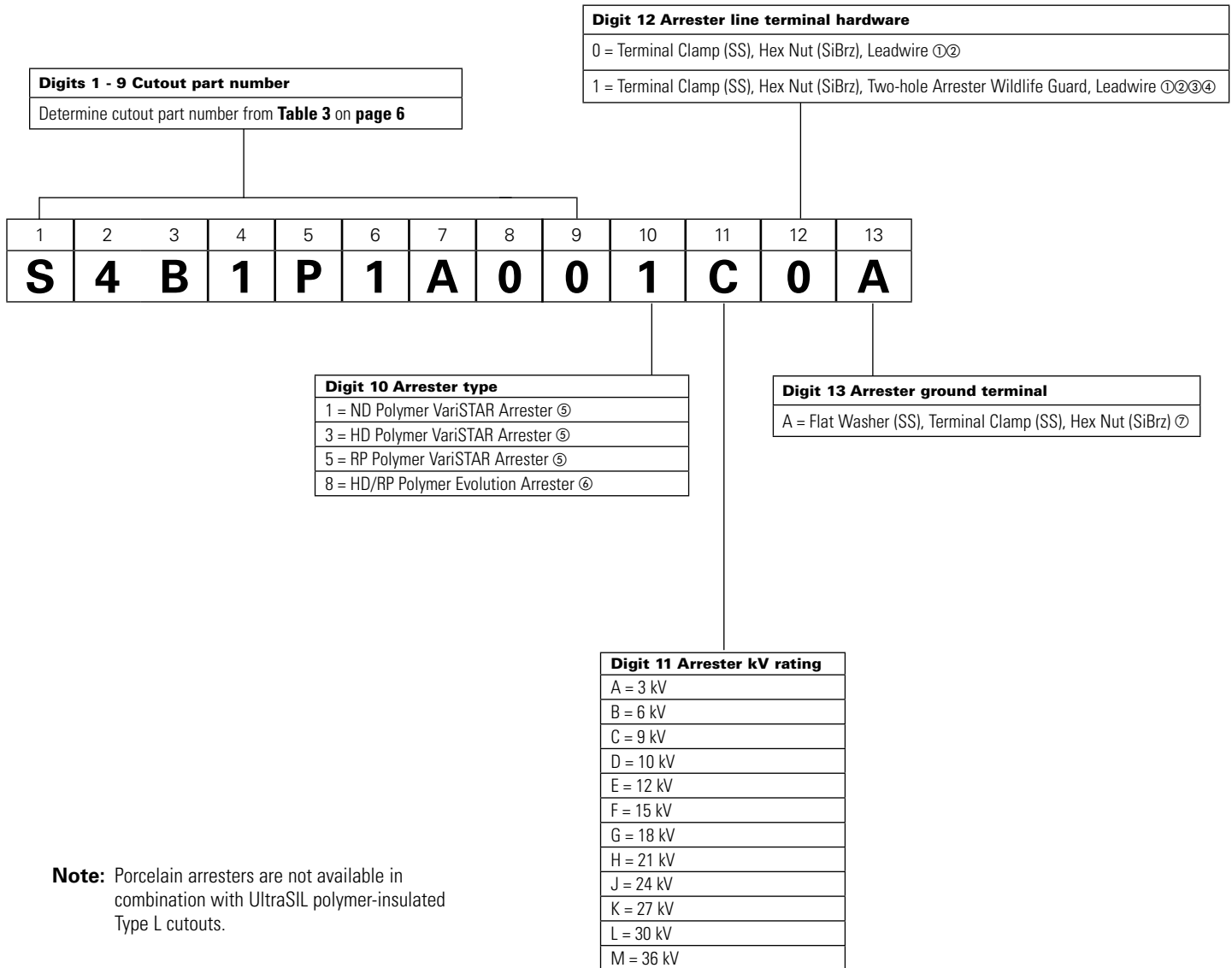

Note: Porcelain arresters are not available in combination with UltraSIL polymer-insulated Type L cutouts.

① Standard arrester line terminal hardware.
 ② 15 kV Type L cutouts w/arrester use 11.0-inch leadwire.
 ③ 27 kV Type L cutouts w/arrester use 9.0-inch leadwire.
 ④ Arrester wildlife guard AV346X1C
 ⑤ See UltraSIL Polymer-Housed VariSTAR arrester catalog section CA235005EN for further information.
 ⑥ See UltraSIL Polymer-Housed Evolution arrester Catalog section CA235018EN for further information.
 ⑦ Standard arrester ground terminal hardware.

Additional information

Refer to the following reference literature for more information:

MN132007EN	Type L Open Distribution Cutout Installation Instructions
MN235004EN	Surge arrester interchangeable fuse cutout combination installation instructions
CP-9618	Type L Open Distribution Cutout Certified Test Report
CA132008EN	Edison™ Links Catalog
CA132031EN	Kearney Fuse Links Catalog
CA132027EN	ELF Current-Limiting Drop Out Fuse Catalog
CA132028EN	Tandem ELF Fuse Catalog
CA235005EN	UltraSIL Polymer-Housed VariSTAR IEEE Surge Arresters; Normal-Duty (5 kA), Heavy-Duty, and Riser Pole (10 kA) for MV Systems to 36 kV
CA132018EN	UltraSIL Polymer-Housed Evolution (10 kV) IEEE Surge Arresters for MV Systems to 36 kV
CA132035EN	UltraSIL Polymer-Insulated and Porcelain Loadbreak Type LB Open Distribution Cutout
PA132010EN	Type LB Open Distribution Cutout Promotional Flyer

Contact your Eaton representative for further information.

Eaton

1000 Eaton Boulevard
Cleveland, OH 44122
United States
Eaton.com

Eaton's Power Systems Division

2300 Badger Drive
Waukesha, WI 53188
United States
Eaton.com/cooperpowerseries

© 2023 Eaton
All Rights Reserved
Printed in USA
Publication No. CA132026EN / ZD28131
October 2023

Eaton is a registered trademark.

All other trademarks are property
of their respective owners.

For Eaton's Cooper Power series product
information, call 1-877-277-4636 or visit:
www.eaton.com/cooperpowerseries.