

M-Force™ three-phase switch

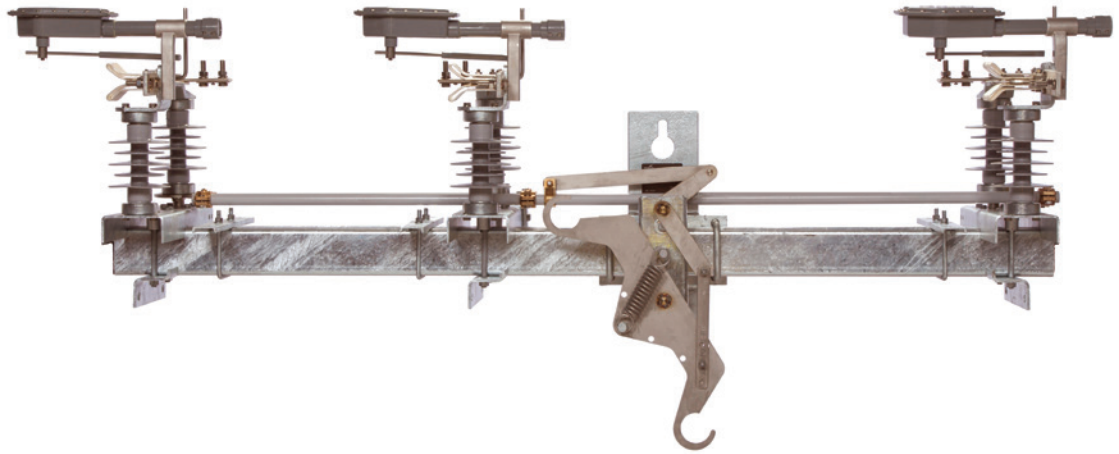

Description

Eaton's Cooper Power™ series M-Force™ switch is a distribution-class, gang-operated, factory unitized three-phase overhead loadbreak switch. The M-Force switch is offered in distribution voltage classifications of 15.5 kV, 27 kV, and 38 kV. The M-Force switch may be used for line sectionalizing, paralleling, by-passing, or isolating.

M-Force stands for "Magnetic Force." Eaton has the only reverse loop contacts found on distribution-class sidebreak switches; a contact usually reserved for higher priced transmission switches. The reverse loop contacts utilize high current magnetic forces for added reliability. The reverse loop design allows for high contact pressure to be maintained during fault conditions. This feature prevents pitting and distorting of the switch blade and contacts even under severe momentary overload.

EATON

Powering Business Worldwide

Basic concept

Current-carrying conductors that are parallel to each other and have current flowing in the same direction, attract each other due to the magnetic forces acting on them (See Figure 1A).

Current-carrying conductors that are parallel to each other and have current flowing in the opposite direction, repel due to the magnetic forces acting on them (See Figure 1B).

Current flows through the two parallel inner segments of the reverse loop contacts in the same direction, thus these two segments attract each other, initiating contact pressure. Current flow through the inner segment and the outer segment is in opposite directions, which causes a repelling force that amplifies the contact pressure.

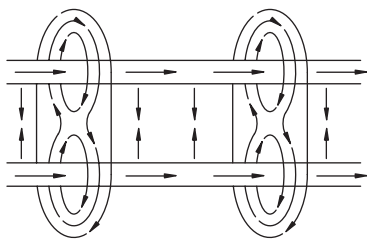

Figure 1A. Current flowing in same direction.

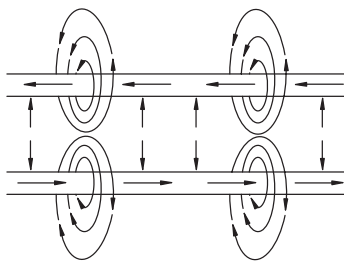

Figure 1B. Current flowing in opposite direction.

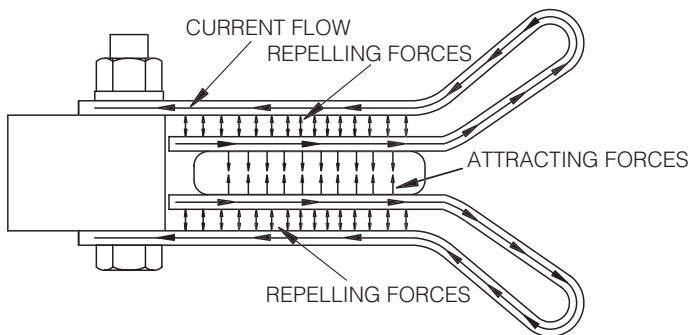

Figure 2. Magnetic forces acting on contacts.

Design features

Reverse loop contacts

The reverse loop contacts utilize high current magnetic forces for added reliability. The reverse loop contacts were adapted from Eaton's Cooper Power series KPF Line Tension Switch and have been field-proven for over 80 years. The reverse loop design allows for high contact pressure to be maintained during fault conditions. This feature prevents pitting and distorting of the switch blade and contacts even under severe momentary overload. These contacts originally designed for high voltage transmission switches also maintain extremely cool temperatures even under the rated full load. The max temperature rise allowed per IEEE Std 1247™-2005 standard for the blade and contact area is 65 °C. The max temperature rise observed on the reverse loop contact area was 38 °C, less than half of the allowed temperature. These types of test results, along with the proven field performance, undoubtedly make the Reverse Loop Contacts found in the M-Force switch the premiere choice in the industry.

Insulators

The M-Force switch comes standard with polymer (silicone rubber) insulators. These non-porcelain insulators offer exceptional dielectric and mechanical characteristics adding to the reliability of the M-Force switch, while lowering the weight. The M-Force switch can be provided in cycloaliphatic epoxy and porcelain housings. Insulators come standard with 2.25" bolt circles at 15 and 25 kV. Insulators require a 3.00" bolt circle at 35 kV.

Extended bearing assembly

The stainless steel shaft on the rotating insulator bearing assembly has been extended to four inches. This extra length will prevent horizontal movement of the rotating insulator during operation which ensures proper blade/contact alignment which is essential for smooth operation. Another feature of the bearing assembly is the oil-impregnated bushings that provide maintenance-free operation for the life of the switch.

Insulated Reliabreak™ arm

The Reliabreak™ Pick-up Arm on the M-Force switch is insulated on one side, which isolates the interrupter from the current path during a close operation. This feature allows for a wide range of adjustments between the Reliabreak arm and the blade catch finger. This increased tolerance removes the possibility of misalignment during operation which ensures proper load interruption.

Positive locking dead-end brackets

The dead-end brackets on the M-Force switch are of a positive locking design. This design allows for dead-ending at an angle without any distortion of the brackets. This allows for a more flexible switch that can be used in a wider variety of installation requirements.

New inter-phase clamps

The inter-phase control rod clamps on the M-Force switch are designed with a jam nut through the side of the casting which locks the clamps after factory alignment. This feature eliminates any possibility of accidental slippage of the control mechanism which ensures proper operation even under icy conditions.

Optional ice shields

The standard M-Force switch is capable of operating under a 3/8" ice build up. With the optional ice shields the M-Force switch is capable of opening and closing with a 3/4" ice build up.

The unique shields are designed to prevent ice from building up between the contact clips as well as removing the ice from the blade during the closing operation. Per IEEE Std C37.34™-1994, a chopping action is allowed during the close operation to break the ice. Due to the shearing action of the M-Force Ice Shields, the closing operation can be accomplished with one motion. No chopping is needed.

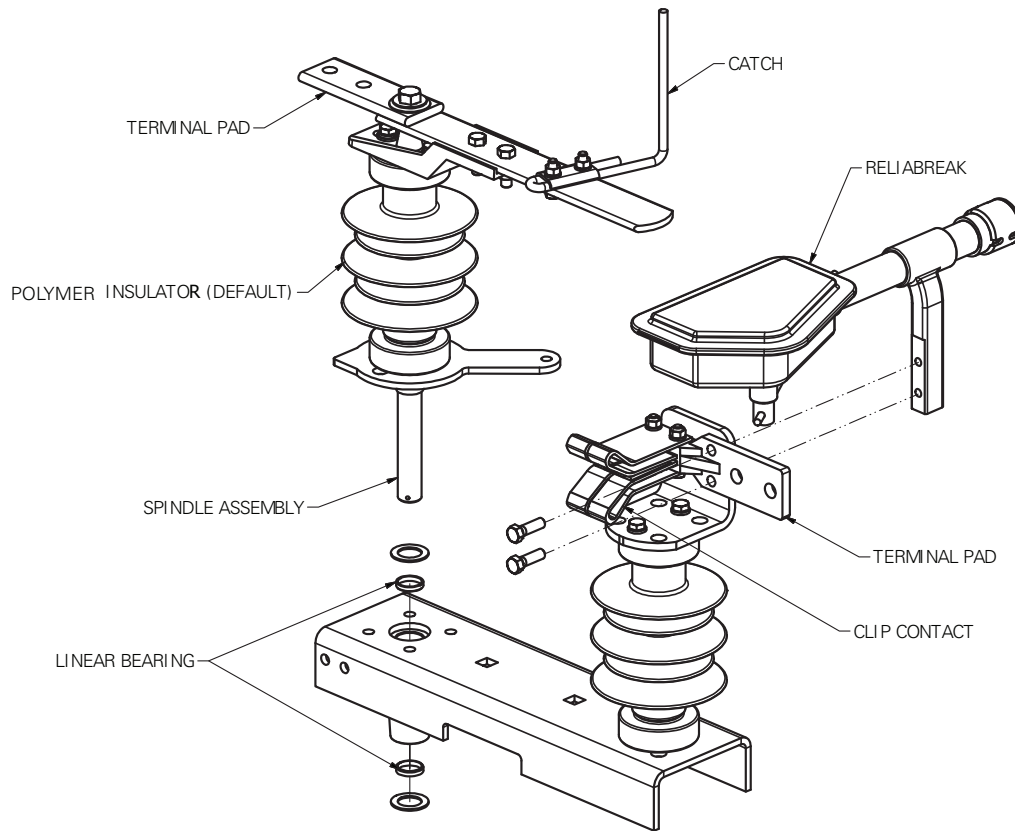

Figure 3. Illustration of M-Force switch.

M-Force switch dimensional data

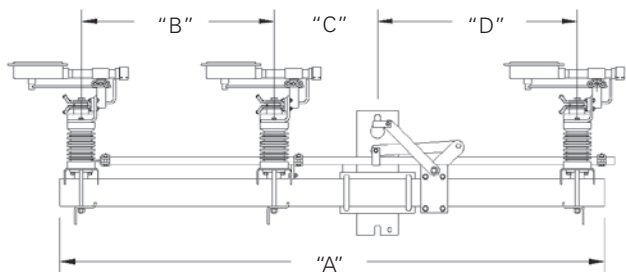

Figure 4. Horizontal switch configuration.

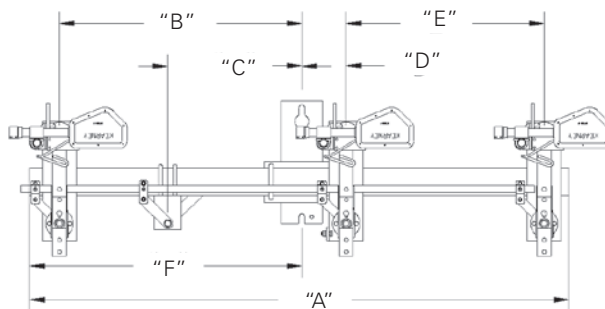

Figure 6. Vertical switch configuration.

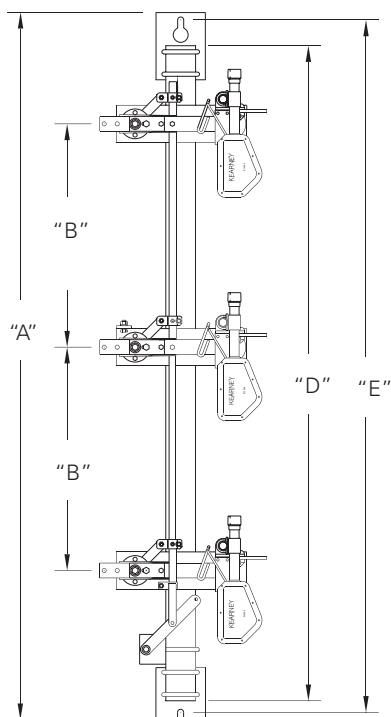

Figure 5. Phase-over-phase switch configuration.

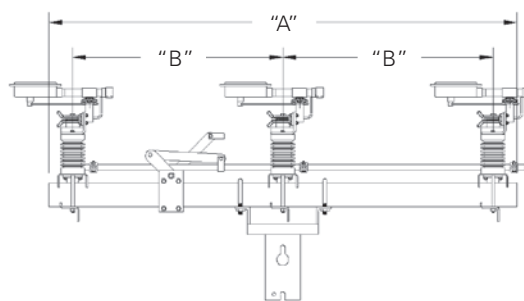

Figure 7. Horizontal Pole top switch configuration.

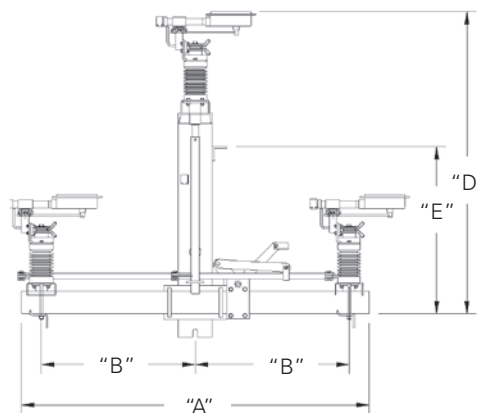

Figure 8. Triangular switch configuration.

Table 1. Dimensional Information

Dim.	Horizontal						Vertical (Riser)						Phase-over-Phase			Triangular		
	Standard		G095		G095		Standard		G095		G095		15.5 kV	27 kV	38 kV	15.5 kV	27 kV	38 kV
A	79"	88"	119"	97"	108"	126"	79"	88"	97"	108"	119"	126"	95"	104"	126"	61"	73"	79"
B	28"	33"	42"	28"	33"	42"	35.5"	40"	45"	49.5"	56"	54.5"	30"	34.5"	45.5"	27"	33"	36"
C	15"	15"	18"	24"	24"	24"	19.5"	19.5"	19.5"	19.5"	19.5"	19.5"	N/A	N/A	N/A	N/A	N/A	N/A
D	29"	33"	52"	38"	43.5"	52.5"	6.5"	6.5"	6.5"	22"	22.5"	22.5"	88"	97"	119"	58"	61"	73"
E	N/A	N/A	N/A	N/A	N/A	N/A	29"	33.5"	45"	29"	33.5"	42"	93"	102"	124"	34"	34"	42"
F	N/A	N/A	N/A	N/A	N/A	N/A	39.5"	45"	48.5"	53.5"	59.5"	58"	N/A	N/A	N/A	N/A	N/A	N/A

Horizontal Pole Top			
Standard			
Dim.	15.5 kV	27 kV	38 kV
A	79"	79"	97"
B	36"	36"	45"

Phase unit dimensions

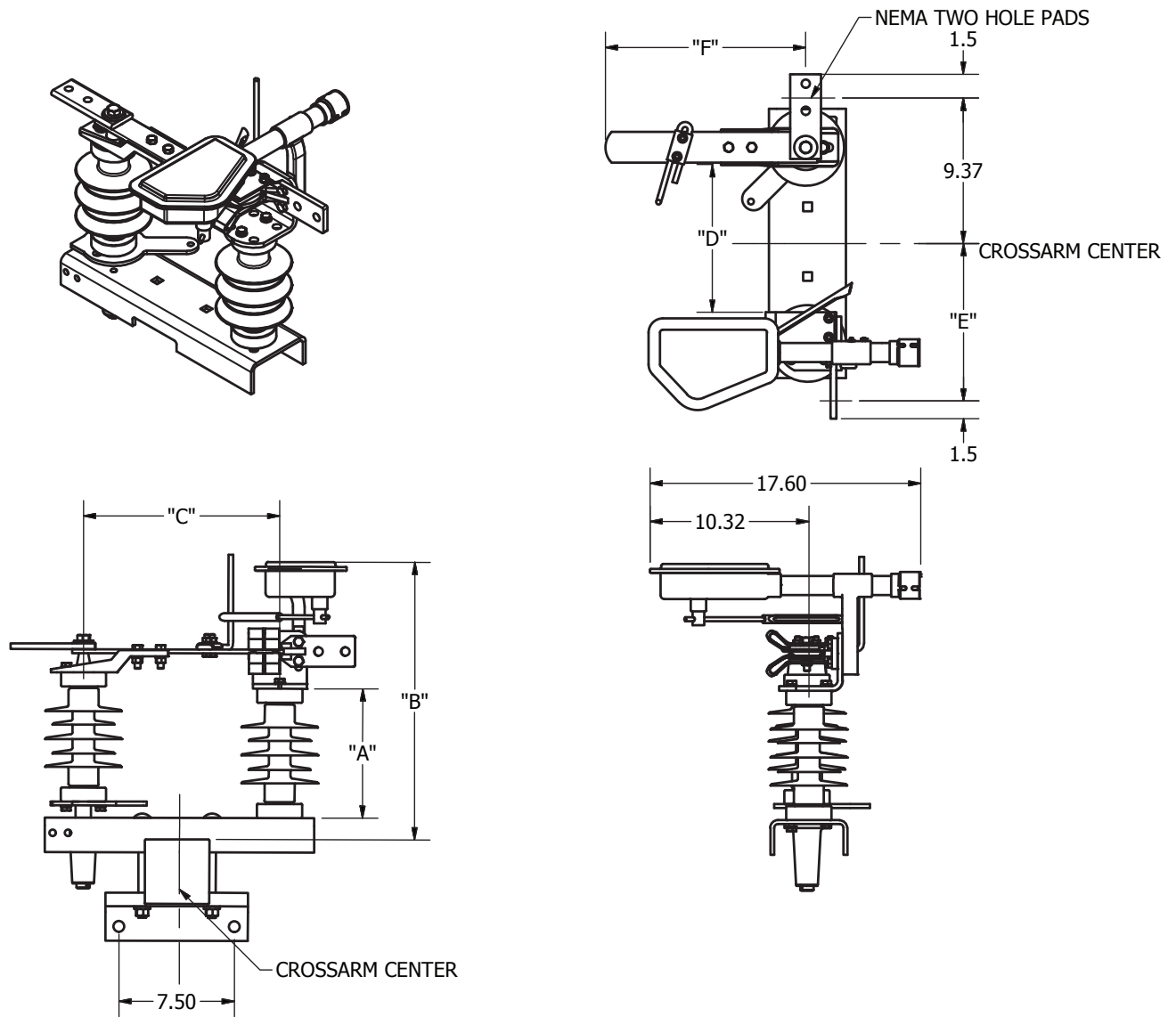

Figure 9. Phase unit breakdown.

Table 2. Phase Unit Dimensions

Dim.	Voltage Class	15.5 kV	27 kV	38 kV
	Insulator Material	2.25" Bolt Circle	2.25" Bolt Circle	3.00" Bolt Circle
A	Polymer	8.4"	10.8"	18.0"
	Epoxy	7.0"	10.0"	14.0"
	Porcelain	8.0"	10.0"	18.0"
B	B = A + 10.00"			
C	12.8"			
D	9.5"			
E	10.0"			
F	13.0"			

Technical specifications

Table 3. Insulator Creep Distances

	2.25" Bolt Circle Insulators		3.00" Bolt Circle Insulators
	15.5 kV	27 kV	38 kV
Polymer Insulators	20.2"	28.0"	37.00"
Epoxy Insulators	18.3"	22.70"	37.69"
Porcelain Insulators	14.0"	17.38"	37.00"

Table 4. Electrical Characteristics

	Max	BIL	Cont. Current	Loadbreak	Momentary*	3 Second	Fault Close (ASM)
14.4 kV	15.5 kV	110 kV	900 A	50 @ 600 A/10 @ 900 A	40 kA Asy. rms	25 kA Sym. rms	1 @ 20 kA, 3 @ 15 kA
25 kV	27 kV	150 kV	900 A	50 @ 600 A/10 @ 900 A	40 kA Asy. rms	25 kA Sym. rms	1 @ 20 kA, 3 @ 15 kA
34.5 kV	38 kV	200 kV	900 A	10 @ 900 A	40 kA Asy. rms	25 kA Sym. rms	1 @ 20 kA, 3 @ 15 kA

* Momentary peak current is 65 kA.

Contacts

- The stationary contact is constructed of silver-plated hard drawn copper in a reverse loop configuration
- The reverse loop design ensures that pressure is applied to the blade when subjected to high fault currents

Blade

- The blade is constructed of silver-plated hard drawn copper of solid blade buss design
- The blade does not use a truss type design that requires backup springs to insure contact pressure
- The blade and contact design are self-wiping and capable of 20,000 mechanical operations without detrimental wear

Reliabreak interrupter

- The internal mechanism of the interrupter is manufactured from non-ferrous components ensuring long term resistance to corrosion in all environments
- The interrupter mechanism can handle 2500 successful mechanical operations
- The interrupter is capable of 10 successful 900 A interruptions or 50 successful 600 A interruptions at 15.5 kV and 27 kV
- The body of the interrupter is manufactured from UV stabilized Lexan® 103 material
- The interrupter operating arm is made of stainless steel (304) with UV stabilized Lexan® 103 insulation molded permanently onto the arm

Phase units

- All current-carrying parts are manufactured from copper
- Terminal pads are NEMA® two hole, silver or tin-plated
- The rotating insulator stack incorporates oil-impregnated bronze bearings to ensure maintenance free operation for life of the switch
- The spindle is manufactured from stainless steel and is supported by bushings spaced at four inches to eliminate rocking of the insulator and to ensure proper blade and contact alignment
- Each phase unit is secured to the crossarm with locking spacers to eliminate distortion of the phase unit base
- Dead-end brackets incorporate locking tabs that will eliminate movement under side forces present when conductor is dead-ended at an angle
- The switch is capable of opening or closing under a 3/8" ice layer without ice shields. The switch shall be capable of opening or closing under a 3/4" ice layer with ice shields.
- Insulator bolt pattern comes standard as 2.25" for 15 kV and 25 kV and 3.00" for 35 kV.

Table 5. Shipping Weights and Dimensions (2.25" Bolt Circle Polymer Insulators Standard, 3.00" on 35 kV)

	Voltage Class	15.5 kV		27 kV		38 kV	
		Crossarm	Steel	Fiberglass	Steel	Fiberglass	Steel
Horizontal Upright	Crate L" x W" x H"	94" x 27" x 34"	94" x 27" x 34"	104" x 30" x 38"	104" x 30" x 38"	134" x 37" x 41"	134" x 37" x 41"
	Weight	381 lbs.	347 lbs.	414 lbs.	380 lbs.	478 lbs.	444 lbs.
Horizontal Pole Top	Crate L" x W" x H"	94" x 27" x 34"	94" x 27" x 34"	94" x 27" x 34"	94" x 27" x 34"	134" x 37" x 41"	134" x 37" x 41"
	Weight	377 lbs.	343 lbs.	410 lbs.	376 lbs.	474 lbs.	440 lbs.
Phase over Phase	Crate L" x W" x H"	100" x 27" x 34"	100" x 27" x 34"	110" x 30" x 38"	110" x 30" x 38"	140" x 37" x 41"	140" x 37" x 41"
	Weight	462 lbs.	428 lbs.	495 lbs.	461 lbs.	559 lbs.	525 lbs.
Vertical Riser	Crate L" x W" x H"	94" x 27" x 34"	94" x 27" x 34"	104" x 30" x 38"	104" x 30" x 38"	134" x 37" x 41"	134" x 37" x 41"
	Weight	402 lbs.	368 lbs.	435 lbs.	401 lbs.	499 lbs.	465 lbs.
Triangular	Crate L" x W" x H"	93" x 27" x 73"	94" x 27" x 73"	93" x 30" x 73"	93" x 30" x 73"	199" x 37" x 85"	99" x 37" x 85"
	Weight	471 lbs.	437 lbs.	504 lbs.	470 lbs.	568 lbs.	534 lbs.

Note: G095 spacing and special switch options will cause slight variations.

Table 6. Weight Adders

	15.5 kV		27 kV		38 kV
	2.25" B.C.	3.00" B.C.	2.25" B.C.	3.00" B.C.	3.00" B.C.
Polymer Insulators	–	14 lbs.	–	3 lbs.	–
Epoxy Insulators	9 lbs.	41 lbs.	14 lbs.	54 lbs.	57 lbs.
Porcelain Insulators	54 lbs.	114 lbs.	57 lbs.	164 lbs.	199 lbs.

Table 7. M-Force Three-Phase Switch Catalog Number Configuration

	M	1	H	11	T	R	2	?
<p>Voltage Class</p> <ul style="list-style-type: none"> 1 - 15.5 kV/110 kV BIL 2 - 27 kV/150 kV BIL 3 - 38 kV/200 kV BIL <p>Mounting Configuration</p> <ul style="list-style-type: none"> H- Horizontal Upright (Standard Option) A- Horizontal Pole Top P- Phase over Phase R- Vertical Riser G- Horizontal Upright (G095 Spacing) S- Vertical Riser (G095 Spacing) T- Triangular U- Underhung (G095 Spacing) <p>Control Rod and Mechanism</p> <p>Reciprocating Mechanism</p> <ul style="list-style-type: none"> 11 - 28' Round Pipe 1.0" O.D. (Standard Option) 21 - 28' Round Fiberglass 41 - 28' 1" Pipe w/Fiberglass Top Section 51 - 28' Pipe w/Cycloaliphatic Insulator <p>Torsional Mechanism</p> <ul style="list-style-type: none"> A2- 28' 1.5" Pipe (Steel Universal Section) B2- 28' 1.5" Pipe (Fiberglass Universal Section) C2- 28' 1.5" Pipe (Cycloaliphatic Insulator) <p>None</p> <ul style="list-style-type: none"> 03- Hookstick operated (no control rod) <p>Crossarm Options</p> <ul style="list-style-type: none"> T - Steel with Single Point Lift (Standard Option) S - Steel with Two Point Lift G - Fiberglass with Single Point Lift F - Fiberglass with Two Point Lift <p>Insulator Material</p> <ul style="list-style-type: none"> R - Polymer (Standard Option) C - Cycloaliphatic Epoxy P - Porcelain 	<p>Options (See Page 9 for details) Note: More than one may be chosen. Append codes in alphanumeric order.</p> <ul style="list-style-type: none"> B - Provisions for Crossarm Support Bracket C - Captive Hardware on Terminal Pads (Incompatible with Option U below) E - Extension Links (14") F - Bonded Reciprocating Control Handle (Standard on Torsional Controls) G - Reciprocating Handle with Interlocks H - Lightning Arrester Brackets I - Steel Interphase Rod J - Provisions for Neutral Wire K - Provisions for Sensors R - Additional Nameplate on Handle S - Ice Shields (3/4" Ice Break on Open or Close Operation) T - Grounding Connector on Crossarm Mounting Bracket U - Terminals, Copper, #2-500 MCM (Incompatible with Option C above) V - Pole Mounting Band 1 - Extra 7' of Control Rod 2 - Extra 14' of Control Rod <p>Insulator Bolt Pattern</p> <ul style="list-style-type: none"> 2 - 2.25" Bolt circle for 15 and 27 kV switches 3 - 3.00" Bolt circle for 35 kV switches <p>Consult factory for other bolt circle options.</p>							

Coastal M-Force Switches

Coastal M-Force switches utilize a corrosion-resistant fiberglass crossarm as a sturdy base for three robust phase units. Stainless steel components and bell crank assembly allow the switch to maintain reliable operation after exposure to salt, moisture and other environmental contaminants.

Coastal M-Force Three-Phase Switch Catalog Number Configuration

CM1 H 03 F R 2 H

CODE	VOLTAGE CLASS
1	15 kV/110 kV BIL
2	25 kV/150 kV BIL
3	35 kV/200 kV BIL

CODE	MOUNTING CONFIGURATION
H	Horizontal Upright (Standard Option)
R	Vertical Riser
P	Phase-over-Phase
G	Horizontal Upright (G095 Spacing)
S	Vertical Riser (GO95 Spacing)

CODE	OPERATING MECHANISM
03	Hookstick Bell Crank, no Rod

CODE	CROSSARM OPTIONS
F	Fiber Glass with Two Point Lift

CODE	OPTIONS - MORE THAN ONE MAY BE CHOSEN
C	Captive Hardware
H	Lightning Arrester Brackets
K	Provisions for Neutral Sensors
S	Ice Shield Kit
T	Ground Connector on Crossarm

Example: CM1H03SR2H – Coastal M-force, 15kV/110kV BIL, Hookstick/Bellcrank operation, Fiberglass crossarm with single point lift, silicone rubber insulator, 2.25" BC, Lightning arrester brackets

CODE	INSULATOR BOLT PATTERN
2	15 or 25 kV
3	35 kV

CODE	INSULATOR MATERIAL
R	Polymer

Definition of options

B-Provisions for crossarm support brackets

The "B" option supplies two adjustment mounting brackets on crossarm. This allows the customer to install support brackets/alley arms to the crossarm. The support brackets are not included.

C-Captive hardware on terminal pads

This option provides two 1-3/4" captive stainless steel studs on each NEMA® two-hole pad. These are usually used in conjunction with compression terminals. This option is incompatible with Option U.

E-Extension links

This option provides two 14" extension links on each conductor dead-end bracket, six per switch.

F-Bonded control handle

This option provides a grounding strap and connector that is attached to the manual operating handle. This is a standard feature on torsional control designs.

G-Reciprocating handles with interlocks

This option provides manual interlocks on switches and is available on switches sold in pairs only. When ordered with this option, end user information such as; utility name, contact person, address, and phone number will have to be provided prior to order input as required by the manufacturer of the interlocks.

H-Lightning arrester brackets

This option provides provisions for the mounting of six lightning arresters per switch.

I-Steel interphase rod

This provides a 1" O.D. steel interphase rod. The standard rod is UV inhibited fiberglass.

J-Provisions for neutral wire

This option provides a hole and spacing for a pin type insulator to be located on the crossarm to accommodate the neutral wire.

K-Provisions for sensors

This option provides longer phase unit bases that will accept sensors to be easily mounted if the manual switches are to be retrofitted for SCADA with a motor operator at a later date.

R-Additional nameplate on handle

This option provides a nameplate fixed to the manual control handle in addition to the nameplate mounted on the switch crossarm.

S-Ice shields

This option provides ice shields on each switch clip contact. This allows the switch to be opened or closed under a 3/4" ice build up.

T-Grounding connector

This option provides a grounding lug on the crossarm mounting bracket. This allows for the utility to ground the switch base to the pole ground.

U-Terminals

This option provides connectors on each two-hole NEMA® pad with a conductor range of #2-500 MCM. This option is incompatible with Option C.

V-Pole mounting band

This option provides the additional support of adjusting pole bands that are attached to the pole mounting bracket.

1-One additional control rod

2-Two additional control rods

Control rod options

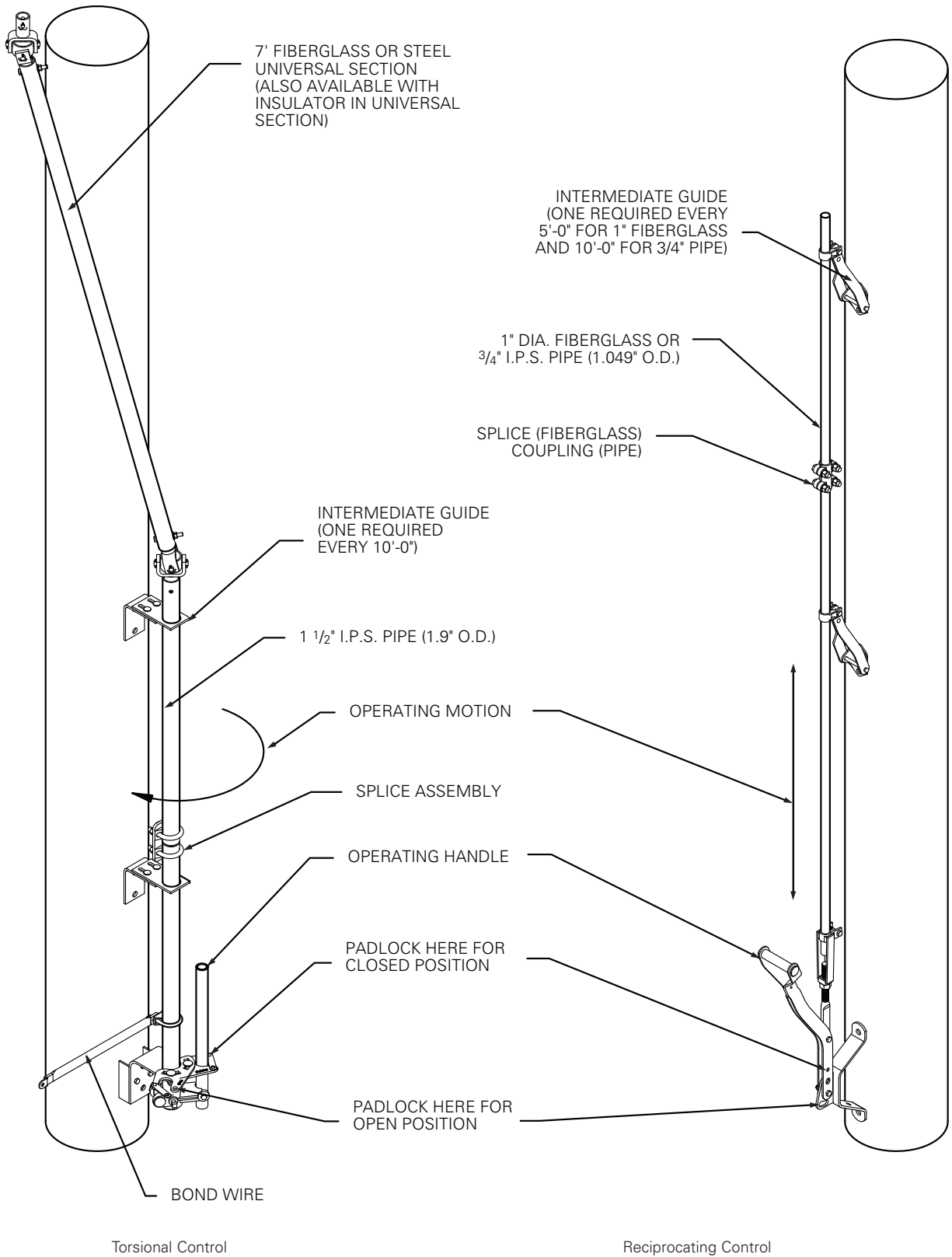

Figure 10. Torsional and Reciprocating control rod options.

Note: The standard length of control rod is 28'. Extra 7' lengths are available (see page 8 for options).

When one section of fiberglass is ordered for reciprocating control, the top section will be designated as that segment.

Eaton
1000 Eaton Boulevard
Cleveland, OH 44122
United States
Eaton.com

Eaton's Power Systems Division
2300 Badger Drive
Waukesha, WI 53188
United States
Eaton.com/cooperpowerseries

© 2020 Eaton
All Rights Reserved
Printed in USA
Publication No. CA008004EN/MCG

Eaton is a registered trademark.

All other trademarks are property
of their respective owners.

For Eaton's Cooper Power series product
information call 1-877-277-4636 or visit:
www.eaton.com/cooperpowerseries.