

DT1-145 AND DT1-170

Dead Tank Circuit Breakers from 123 kV to 170 kV

The DT1-145 and the DT1-170 are dead tank circuit breakers suitable for applications at 170 kV and below. They are specifically designed and tested for general or definite purpose applications as well as for severe environmental conditions including low temperature, highly active seismic areas, and regions with high pollution levels or corrosive atmospheres.

Reliable Performance

The DT1-145 and the DT1-170 are suitable for applications up to nameplate ratings, including definite purpose ratings. Extensive mechanical design testing to 10,000 operations and Class M2 certification ensure trouble-free operation for the lifetime of the circuit breaker.

Gas Tightness Guarantee & Superior Manufacturing

Grid Solutions at GE Vernova leads the industry in SF₆ gas tightness testing technology including seals, castings, and plumbing systems. Each breaker is factory-tested using Grid Solutions' proprietary gas tightness testing system which provides measurable, quantifiable test results on the breaker in its fully assembled, as-shipped condition.

Grid Solutions designs, manufactures, tests, and delivers its circuit breakers in accordance with the latest IEEE/ANSI and IEC standards, maintaining a quality assurance system according to ISO 9001 and ISO 14001 certifications. The center of excellence for dead tank circuit breakers is located in Charleroi, PA (USA).

Enhanced Installation and Maintenance

The DT1-145/170 are factory-tested and adjusted and do not require any "special tools" for the installation. Designed with the smallest symmetrical footprint to allow for minimized foundation costs, they are recognized worldwide as easy-to-install and easy-to-operate circuit breakers. Due to the low-energy mechanism and lifetime lubricants, the DT series is virtually maintenance-free. For installations where truck shipment is impossible, all DT series circuit breakers can be readied for standard container shipment with only their bushings disassembled.

IPO Option

The DT1-145 and the DT1-170 are also available in Independent Pole Operation (IPO) configuration with a separated spring/spring mechanism for each phase. Paired with a synchronous controller, this can be used for point-on-wave switching of shunt capacitor or shunt reactor banks.



Main Characteristics

- Advanced self-blast interrupters
- Leak-resistant cast aluminum enclosures
- Durable low-energy spring-spring-operated mechanism
- More than 100,000 circuit breakers with self-blast interrupters and FK spring-operated mechanism in service since 1989

Key Benefits

- SF₆ gas tightness guarantee
- High performance ratings
- Reliability under the most severe conditions
- Design customization
- Virtually maintenance-free
- Easy to install



Technical Data

	VALUE	UNITS
SF ₆ pressure	93/0.64	psig/Mpa
Motor	1,600	watts
Close coil/Trip coil	440/440	watts
Ambient temperature range*	-30 to +40	degree C
High seismic capability in accordance with IEEE 693-2005		
Weight (without current transformers)	4,180/1,900	lb/kg

* Optional values available upon request

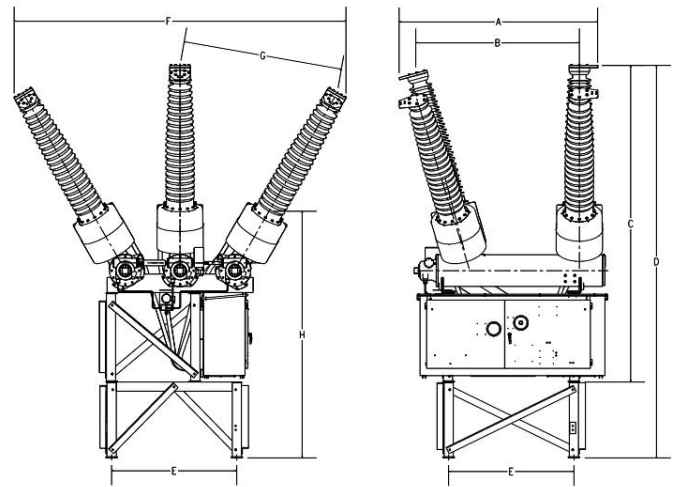

Dimensions

RATED MAX. VOLTAGE	A (in/mm)	B (in/mm)	C (in/mm)	D (in/mm)	E (in/mm)	F (in/mm)	G (in/mm)	H (in/mm)
145 kV	90/2,284	70/1,779	136/3,459	169/4,289	54/1,372	90/2,284	69/1,747	102/2,600
170 kV	90/2,366	73/1,849	146/3,719	179/4,549	54/1,372	153/3,898	74/1,881	102/2,591

Ratings

IEEE	IEC	VALUE	UNITS
Rated maximum voltage	Rated voltage	123/145/170	kV
Rated power frequency	Rated frequency	50/60	Hz
Rated dielectric withstand capability	Rated insulation level		
- dry withstand	- at power frequency, dry	260/310/365	kV
- wet withstand	- at power frequency, wet	230/275/315	kV
Rated lightning impulse withstand voltage	- at lightning impulse	550/650/750	kV
Rated chopped wave impulse voltage 2us		710/838/968	kV
Rated continuous current	Rated normal current	1,200/2,000/3,000	A
Rated short-circuit current	Rated short-circuit breaking current	40	kA
Rated closing, latching, and short-time carrying		104	kA
Rated capacitance switching*			
	Rated single capacitor bank breaking current	400	A
Rated interrupting time		3	cycles
	Rated break time	50	ms
Rated standard operating duty	Rated operating sequence	0-0.3s-C0-15s-C0	

*Ratings available upon request.

**Please contact us for special purpose, high TRV, high X/R or other rating requirements.

For more information visit GEGridSolutions.com

IEC is a registered trademark of Commission Electrotechnique Internationale. IEEE is a registered trademark of the Institute of Electrical Electronics Engineers, Inc.

GE, and the GE monogram are trademarks of General Electric Company. GE reserves the right to make changes to specifications of products described at any time without notice and without obligation to notify any person of such changes.

© 2024 GE Grid Solutions, LLC, a GE Vernova company, and/or affiliates. All rights reserved.

GEA-33267-(E)
English
240501

