

200 A 15 kV class loadbreak junction

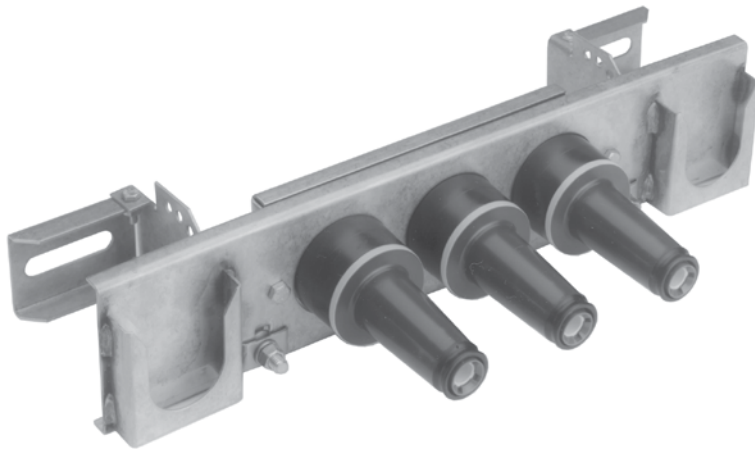

General

Eaton's Cooper Power™ series 200 A, 15 kV Class loadbreak junction provides two, three or four 8.3/14.4 kV loadbreak interfaces that are internally bused together and meet all requirements of IEEE Std 386™-2006 standard, Separable Insulated Connector Systems. Loadbreak junctions are used in pad-mounted apparatus, underground vaults, and other apparatus to sectionalize, establish loops, taps, or splices, and to facilitate apparatus changeouts. Sectionalizing a cable run to find and isolate a cable fault is made easy when a loadbreak junction is used with 15 kV Class loadbreak elbows and other accessories meeting the requirements of IEEE Std 386™-2006 standard. When mated with a comparably rated product, the junction provides a fully shielded, submersible, separable connection for loadbreak operation.

The junction has a continuous solid current path of all copper alloy. No aluminum components are used. It also has an ablative arc interrupter with superior de-ionizing properties. The body is molded of high quality peroxide-cured EPDM insulation and has a molded on peroxide-cured semi-conductive EPDM shield.

Cooper's latch indicator ring, located on the circumference of the interface collar, eliminates the guesswork of loadbreak elbow installation on the interface. The bright yellow ring provides immediate feedback to determine if the elbow is properly installed on the junction. If the yellow ring is completely covered by the loadbreak elbow, the elbow is fully "latched." If the ring is visible, the elbow is not fully installed, so the operator can correct it before any problems occur.

The loadbreak junction has an adjustable stainless steel bracket for mounting at various operating angles on flat or curved surfaces, with up to 90° tilt in 10° increments. The solid backplated channel provides strong, rigid support of the junction for optimum loadbreak operation. Parking stands accommodate insulated standoff bushings or portable feedthrus. Drain wire clamps can each accommodate two wires up to 1/0 stranded (3/8" diameter).

Stainless steel "U" straps are available for direct wall mounting.

EATON

Powering Business Worldwide

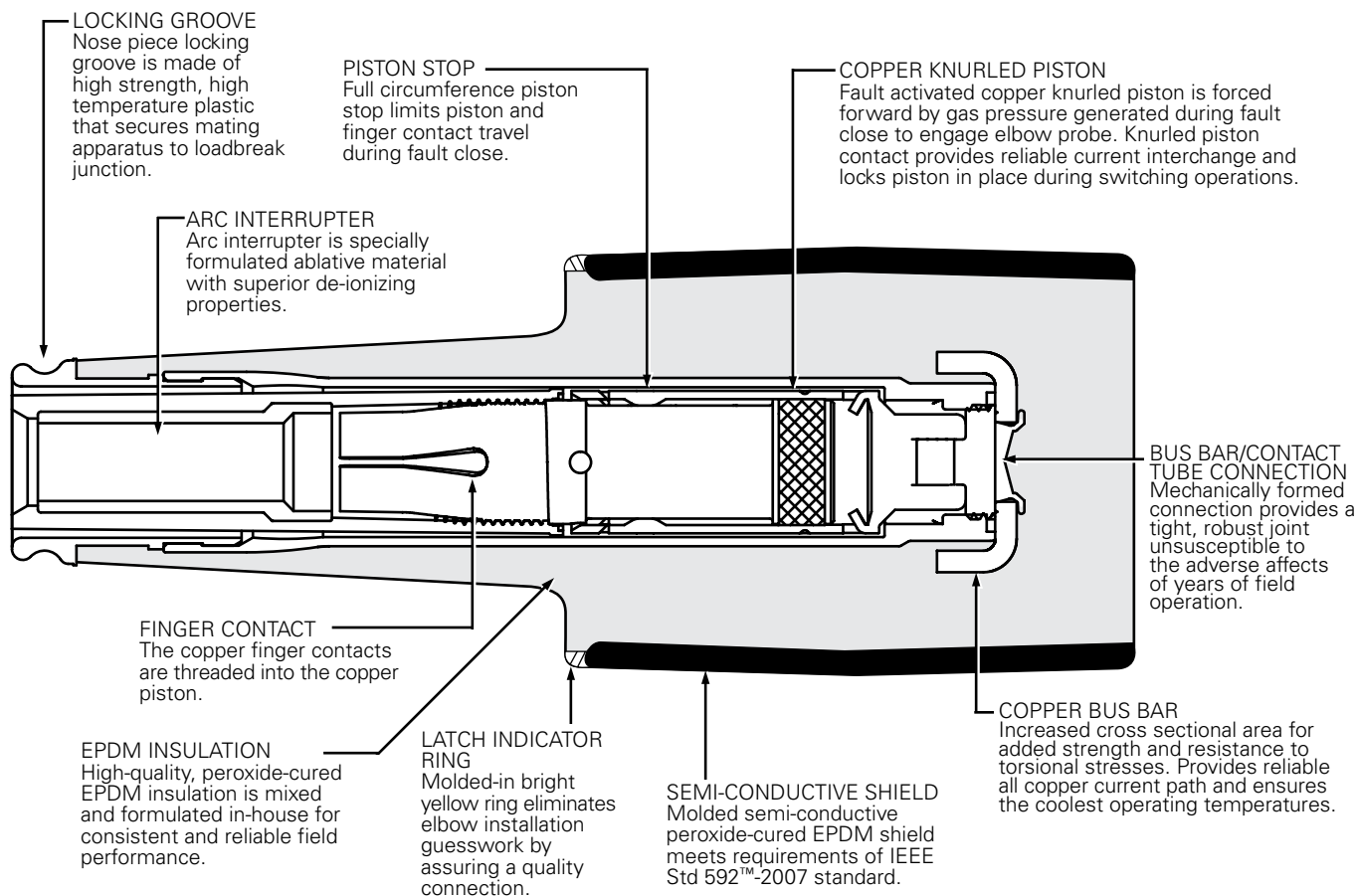

Figure 1. Illustration shows cutaway of loadbreak junction with continuous current path of all copper alloy. Field proven, all copper alloy current path ensures the coolest operating temperatures and reliable current flow.

Installation

No special tools are required. Junctions are bolted to the mounting surface. Refer to *Service Instructions MN650015EN* for details.

Production tests

Tests conducted in accordance with IEEE Std 386™-2006 standard:

- AC 60 Hz 1 Minute Withstand
 - 34 kV
- Minimum Corona Voltage Level
 - 11 kV

Tests conducted in accordance with Eaton requirements:

- Physical Inspection
- Periodic Dissection
- Periodic Fluoroscopic Analysis

Table 1. Voltage Ratings and Characteristics

Description	kV
Standard Voltage Class	15
Maximum Rating Phase-to-Phase	14.4
Maximum Rating Phase-to-Ground	8.3
AC 60 Hz 1 Minute Withstand	34
DC 15 Minute Withstand	53
BIL and Full Wave Crest	95
Minimum Corona Voltage Level	11

Voltage ratings and characteristics are in accordance with IEEE Std 386™-2006 standard.

Table 2. Current Ratings and Characteristics

Description	Amperes
Continuous	200 A rms
Switching	10 operations at 200 A rms at 14.4 kV
Fault Closure	10,000 A rms symmetrical at 14.4 kV for 0.17 s after 10 switching operations
Short Time	10,000 A rms symmetrical for 0.17 s 3,500 A rms symmetrical for 3.0 s

Current ratings and characteristics are in accordance with IEEE Std 386™-2006 standard.

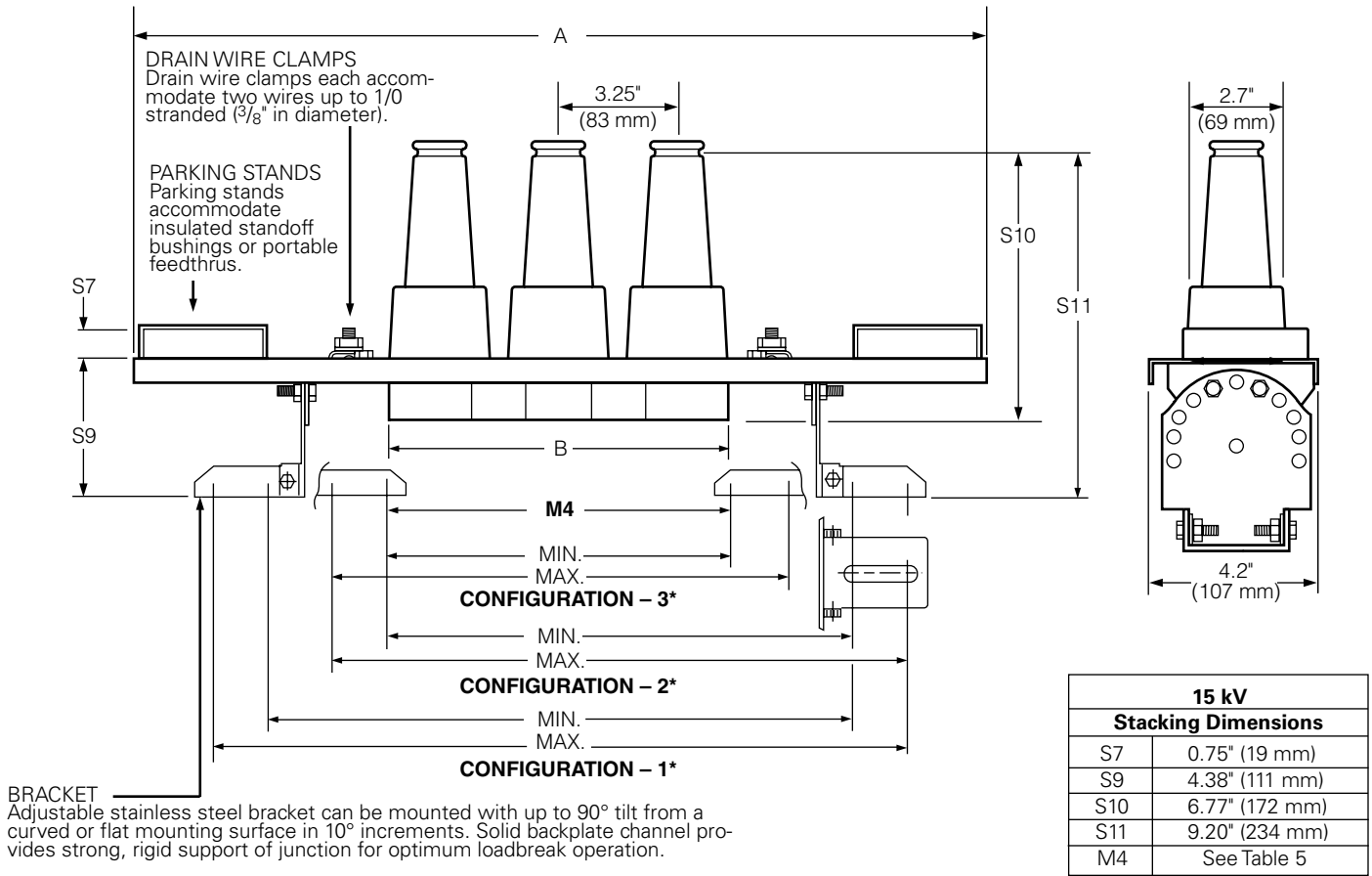

Figure 2. Dimensional drawing shows mounting configurations.

Note: Dimensions given are for reference only.

Table 3. Dimensional Information

Number of Interfaces	Physical Dimensions in. (mm)		M4 Mounting Dimensions in. (mm)					
			Configuration 1		Configuration 2		Configuration 3	
	A	B	Min.	Max.	Min.	Max.	Min.	Max.
2	12.5 (318)	6.0 (152)	10.8 (275)	14.4 (366)	7.2 (183)	10.8 (275)	3.6 (92)	7.2 (183)
3	19.6 (498)	9.2 (230)	14.7 (374)	18.3 (465)	11.1 (282)	14.7 (374)	7.4 (188)	11.1 (282)
4	22.9 (582)	12.4 (315)	17.9 (455)	21.5 (547)	14.3 (364)	17.9 (455)	10.7 (272)	14.3 (364)

* Configuration 1. Both feet turned out.
 Configuration 2. One foot turned out, one in.
 Configuration 3. Both feet turned in.

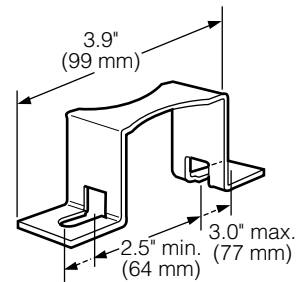

Figure 3. Stainless steel U-Strap for direct wall mount.

Note: Dimensions given are for reference only.

Ordering information

To order the 15 kV Class (8.3/14.4 kV) Loadbreak Junction, refer to Table 4.

Each kit contains:

- Loadbreak Junction (with mounting bracket or straps, depending on product ordered)
- Shipping Caps (not for energized operation)
- Installation Instruction Sheet

Table 4. Loadbreak Junctions

Number of Interfaces	Junction Only	Junction with U-Straps	Junction with Stainless Steel Bracket
2	LJ215C2	LJ215C2U	LJ215C2B
3	LJ215C3	LJ215C3U	LJ215C3B
4	LJ215C4	LJ215C4U	LJ215C4B

Table 5. Replacement Parts

Description	Catalog Number
U-Strap Kit with Hardware (1 strap)	2625439A16B
Stainless Steel Bracket Assembly (2-way)	2637172B01BS
Stainless Steel Bracket Assembly (3-way)	2637172B02BS
Stainless Steel Bracket Assembly (4-way)	2637172B03BS

Eaton
1000 Eaton Boulevard
Cleveland, OH 44122
United States
Eaton.com

Eaton's Power Systems Division
2300 Badger Drive
Waukesha, WI 53188
United States
Eaton.com/cooperpowerseries

© 2021 Eaton
All Rights Reserved
Printed in USA
Publication No. CA650102EN
May 2021

Eaton is a registered trademark.

All other trademarks are property of their respective owners.

For Eaton's Cooper Power series product information call 1-877-277-4636 or visit: www.eaton.com/cooperpowerseries.