

600 A 35 kV class deadbreak junction

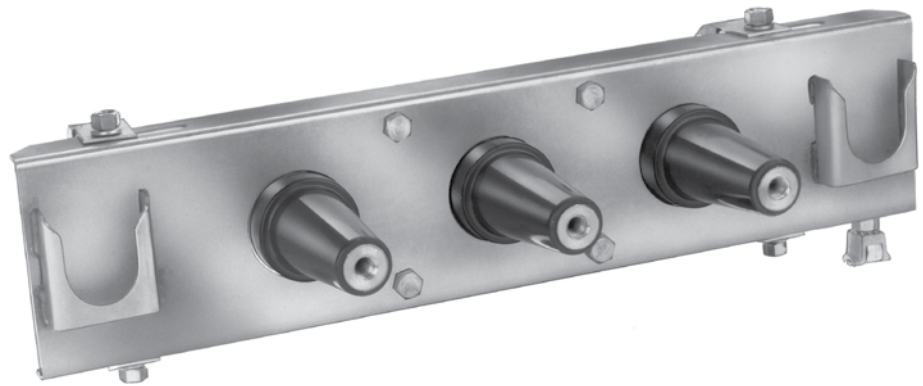

General

Eaton provides two, three, or four deadbreak interfaces bused together and encapsulated in a precision molded peroxide cured EPDM insulated rubber body with a semiconductive outer shield in its Cooper Power™ series 600 A, 35 kV Class deadbreak junction. Deadbreak junctions are used in pad-mounted apparatus, underground vaults, and other installations to establish loops, taps and splices, and facilitate apparatus change-outs.

Sectionalizing a cable run to find and isolate a cable fault is made easy when a deadbreak junction is used with deadbreak connectors meeting the requirements of IEEE Std 386™ –2006 standard, "Separable Insulated Connector Systems".

When mated with a comparably rated product, the junction provides a fully shielded, submersible, threaded connection for deadbreak operation.

The deadbreak junction is available with stainless steel adjustable brackets for mounting flat or at a 45° angle. Stainless steel "U" straps are available for direct wall mounting.

EATON

Powering Business Worldwide

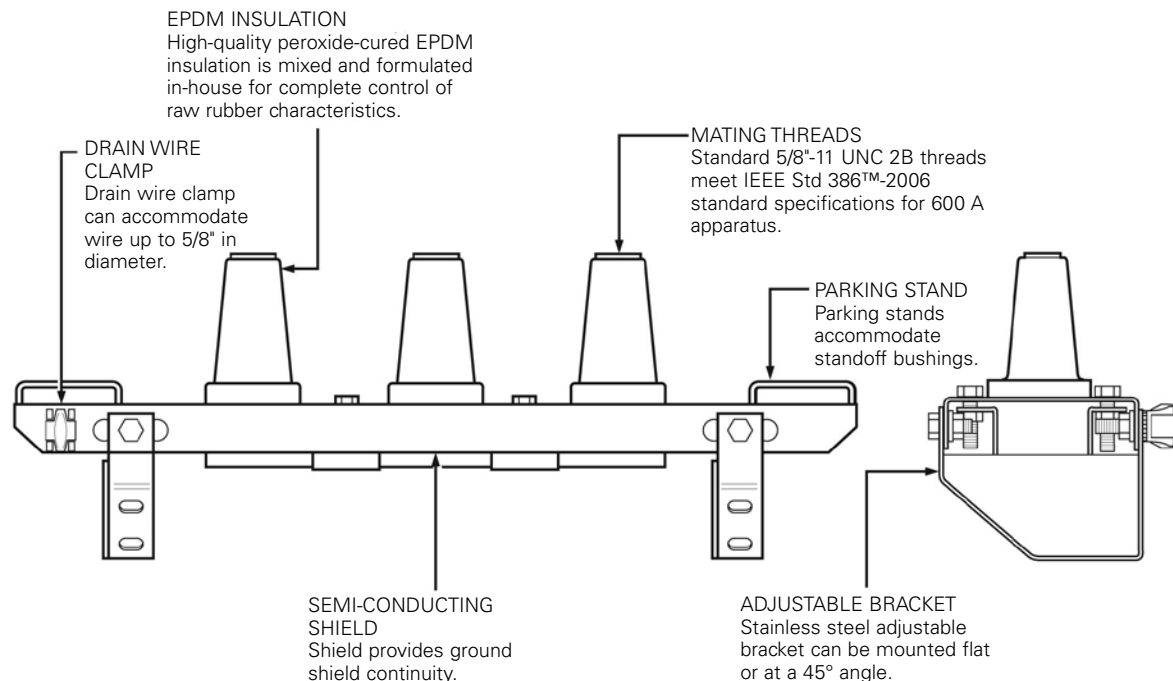

Figure 1. Welded current path ensures cool operating temperatures. Bus bar and taps are welded together for high electrical and mechanical reliability.

900 Amp rating

The deadbreak junction is rated for 900 A continuous when the copper junction and copper mating components are specified. See Table 4.

200 kV BIL rating

The 35 kV class deadbreak junction is available with an optional 200 kV BIL rating, which allows you to match the BIL rating of the system and the equipment to which it will be connected.

Additional available options

For additional available options, refer to *Catalog Section 650-10, 200 A and 600 A, 15, 25, and 35 kV Junction Bars for Separable Connectors*. Options include:

- In-line junctions with up to six (6) positions
- Junctions with combinations of 200 A wells and 600 A bushings
- "L" splice configurations
- "Y" splice Configurations. Single-phase and three-phase.
- Stacked configuration

Installation

Deadbreak junctions are bolted to the mounting surface. 600 A connectors are assembled onto junctions using tools as described in the appropriate installation instructions for those connectors. Refer to *Service Information S600-22-1, 600 A, 15, 25, and 35 kV Class Deadbreak Junction Installation Instructions* for junction dimensions and mounting details.

Table 1. Voltage Ratings and Characteristics

Description	kV
Standard Voltage Class	35
Maximum Rating Phase-to-Ground	21.1
AC 60 Hz 1 Minute Withstand	
150 kV BIL Class Junction	50
200 kV BIL Class Junction	70
DC 15 Minute Withstand	103
BIL and Full Wave Crest	150/200
Minimum Corona Voltage Level	26

Voltage ratings and characteristics are in accordance with IEEE Std 386™-2006 standard.

Production tests

Tests are conducted in accordance with IEEE Std 386™-2006 standard:

- ac 60 Hz 1 Minute Withstand
 - 50 kV/70 kV
- Minimum Corona Voltage Level
 - – 26 kV

Tests are conducted in accordance with Eaton requirements:

- Physical Inspection
- Periodic Dissection
- Periodic Fluoroscopic Analysis

Table 2. Current Ratings and Characteristics

Description	Amperes	
Continuous	600 A rms (Aluminum)	900 A rms (Copper)
4 Hour Overload	900 A rms (Aluminum)	1,200 A rms (Copper)
Short Time	40,000 A rms symmetrical for 0.20 s 10,000 A rms symmetrical for 3.0 s	

Current ratings and characteristics are in accordance with IEEE Std 386™-2006 standard.

Ordering information

To order a 35 kV Class Deadbreak Junction, see Tables 3 and 4.

Each kit contains:

- Deadbreak junction (with mounting bracket or straps, depending on product ordered)
- Shipping Caps (not for energized operation)
- Installation Instruction Sheet

If aluminum 5/8"-11 threaded stud is required for assembly, specify STUD635-A. For copper threaded stud specify STUD635-C. For the TOP™ II connector stud, specify STUD-T.

Table 3. Aluminum Deadbreak Junction Selection Chart

Number of Interfaces	Junction Only		Junction with U-Strap		Junction with Bracket	
	150 kV	200 kV	150 kV	200 kV	150 kV	200 kV
2	DJ635A2	DJ638A2	DJ635A2U	DJ638A2U	DJ635A2B	DJ638A2B
3	DJ635A3	DJ638A3	DJ635A3U	DJ638A3U	DJ635A3B	DJ638A3B
4	DJ635A4	DJ638A4	DJ635A4U	DJ638A4U	DJ635A4B	DJ638A4B

Table 4. Copper Deadbreak Junction Selection Chart

Number of Interfaces	Junction Only		Junction with U-Strap		Junction with Bracket	
	150 kV	200 kV	150 kV	200 kV	150 kV	200 kV
2	DJ635C2	DJ638C2	DJ635C2U	DJ638C2U	DJ635C2B	DJ638C2B
3	DJ635C3	DJ638C3	DJ635C3U	DJ638C3U	DJ635C3B	DJ638C3B
4	DJ635C4	DJ638C4	DJ635C4U	DJ638C4U	DJ635C4B	DJ638C4B

Table 5. Replacement Parts

Description	Catalog Number
"U" Strap Kit with Hardware (1 strap)	2637570A02B
Stainless Steel Bracket Assembly (2-way)	2637195C01B
Stainless Steel Bracket Assembly (3-way)	2637195C02B
Stainless Steel Bracket Assembly (4-way)	2637195C03B

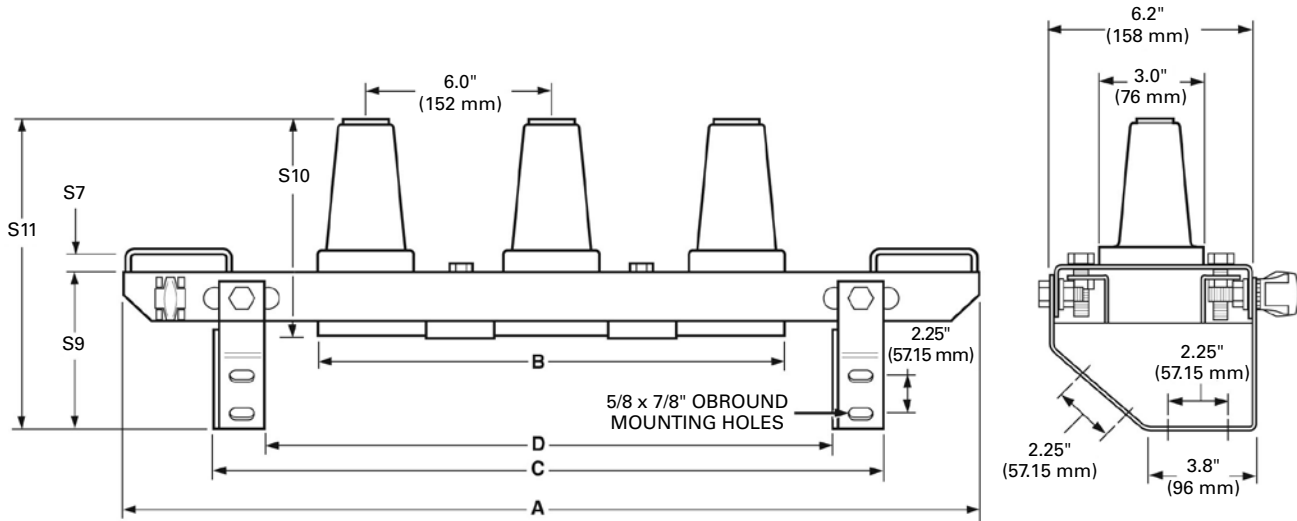

35 kV Stacking Dimensions

S7	0.75" (19 mm)
S9	5.55" (141 mm)
S10	7.0" (178 mm)
S11	10.4" (264 mm)

Figure 2. Dimensional drawing shows mounting configuration.

Note: Dimensions given are for reference only.

Table 6. Dimensional Information

Number of Interfaces	Physical Dimensions in. (mm)		Mounting Dimensions in. (mm)	
	A	B	C	D
2	21.5 (546)	9.0 (229)	15.5 (394)	12.5 (318)
3	27.5 (699)	15.0 (381)	21.5 (546)	18.5 (470)
4	33.5 (851)	21.0 (533)	27.5 (699)	24.5 (622)

Note: C and D are minimum and maximum stud centerline separations for mounting.

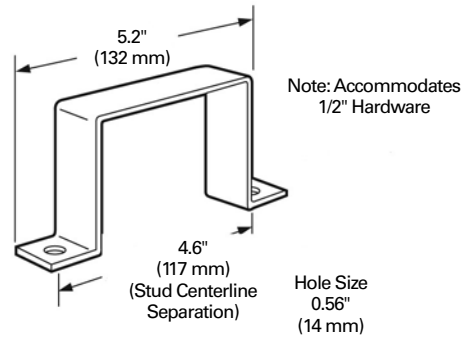

Figure 3. Stainless steel "U" strap for direct wall mount.

Note: Dimensions given are for reference only.

Eaton
 1000 Eaton Boulevard
 Cleveland, OH 44122
 United States
 Eaton.com

Eaton's Cooper Power Systems Division
 2300 Badger Drive
 Waukesha, WI 53188
 United States
 Eaton.com/cooperpowerseries

© 2015 Eaton
 All Rights Reserved
 Printed in USA
 Publication No. CA650053EN

Eaton, Cooper Power, and T-OP are valuable trademarks of Eaton in the U.S. and other countries. You are not permitted to use these trademarks without the prior written consent of Eaton.
 IEEE Std 386™-2006 standard are trademarks of the Institute of Electrical and Electronics Engineers, Inc., (IEEE). This publication is not endorsed or approved by the IEEE.

For Eaton's Cooper Power series T-OP connector product information call 1-877-277-4636 or visit: www.eaton.com/cooperpowerseries.