

## TYPE FTDF FUSED SECTIONALIZER PAD-MOUNTED SWITCHGEAR WITH ELBOW SWITCHING

The Type FTDF Pad-Mounted Switchgear offers dead-front load-break elbow switching of radial and loop feed systems with (non-loadbreak) fuse protection on laterals and taps. FTDF's are available in 15kV and 25kV voltage class, single and three-phase with either general-purpose type current-limiting or expulsion-type power fuses.

The basic enclosure has been designed to present the lowest possible silhouette, yet maintaining ample operating and electrical clearances. An all-welded 11-gauge steel construction provides additional strength and rigidity to the housing. Doors have flush handle with padlocking provisions and a separate penta-head security bolt operates with a three-point latching system. Ventilation louvers are of baffle and screen construction that allows air to circulate and prevents the insertion of wire or other foreign material. These standard features, along with a rugged tamper-resistant design, provide a unit that meets the stringent security requirements of ANSI C57.12.28.

FTDF cabinets are divided into two compartments. Elbow compartments consist of a steel equipment panel with in-air bushing wells to accept load-break inserts and elbow, one parking stand per bushing well, and phase, line and load designations. Fuse compartments contain applicable non-loadbreak fuse mountings and phase barriers and hinged inner barriers of red fiberglass and complete with penta-head bolts. Loadbreak fuse mountings are available as an option. Barriers of clear polycarbonate are available as an option.

High-quality steel, corrosion-resistant hardware, chemical cleaning and phosphatizing, corrosion-resistant epoxy-powder primer and a baked powder finish coat make the anti-corrosion coating system a leader in the industry. The finish coat is an oven-baked polyurethane; standard color is pad-mount green, Munsell Notation 7.0 GY 3.29/1.5. Optional colors and severe environmental systems are available. The underside of the roof section is coated with a "no-drip" anti-condensation compound.

A wide range of optional features are available, including hex-head security bolts and base spacers to increase cable training height and 600 amp dead-break apparatus bushings on line side.



Figure 1. Exterior views of the ELBOW side (top) and the FUSE side (bottom) of a typical FTDF sectionalizer.

### OPTIONAL FEATURES

<b>AB</b>	600 amp dead-break apparatus bushing on line side.
<b>AJ4Z</b>	Auto-jet fuse mounting and live parts only. Requires S&C SML-4Z fuseholders.
<b>AJ20</b>	Auto-jet fuse mounting and live parts only. Requires Federal Pacific FP-3097, S&C SML-20, Cutler-Hammer DBU or Cooper CMU fuse end fittings.
<b>AS</b>	Arc strangler fuse mounting, Mounting Code 1 or 2.
<b>B6*</b>	Inner insulating doors, complete with hex-head bolt, fuse side only.
<b>BSC6</b>	Base spacer, 6 inch, compartmented.
<b>BSC12</b>	Base spacer, 12 inch, compartmented.
<b>F2</b>	Finish, light gray, ANSI, instead of green.
<b>LBI</b>	Load-break bushing inserts for all line and load bushing wells.
<b>LF</b>	Live fuse termination (delete load-side bushings).
<b>SB2</b>	Security bolts hex-head instead of penta-head.
<b>U2</b>	Coal tar base and 3" up all sides.

\*Meets requirements of Section 381.G National Electric Safety Code.

## APPLICATION DATA

**CL Designation:** Standard current-limiting fuse mountings are Code 5/6 for mounting Cooper NX; Cooper ELX; General Electric GP and Cutler-Hammer CX clip style fuses. The Code 5/6 mountings provide a fuse range of 1.5 to 100 amps at 13.5kV, 1.5 to 80 at 15.5kV and 6 to 40 amps at 23kV. Arc-strangler fuse mountings Code 2 are available at 15.5kV with a fuse range of 1.5 to 40 amp. Other current-limiting fuses are available on special order. Fuse mountings only are supplied; fuse units can be provided as an option.

**PF Designation:** Standard power fuse mountings accommodate S&C SM-4Z or SM-20, Eaton (Cutler-Hammer) DBU, or Cooper CMU all with a fuse range of 1 to 200 amps at 15.5 and 25kV. Other power fuses are available on special order. Fuse mountings only are supplied; fuseholders, refills, end fittings and fuse units can be provided as an option.

Auto-jet load-break fuse integral load interrupter as described on page 13 is available as an option. The Auto-jet fuse mounting has a load interruption mechanism that permits single-phase switching of the fused circuit by use of an ordinary hotstick equipped with an appropriate fuse-handling tool. Fuse mountings and end fittings only are supplied; fuseholders and refills can be provided as an option.

**Bushing Wells and Bushings:** Federal Pacific bushing wells are provided to accept optional load-break inserts and customer elbows. Bushing wells and bus are rated 200 amps continuous, 95kV BIL on 15kV units and 125kV BIL on 25kV units. Bushings and bushing wells meet the requirements of ANSI 386 standard.

**Elbow Switching:** The 15kV units are designed for use on 15kV class, 4-wire multi-grounded systems or 3-wire ungrounded systems. Elbow switching, 200 amperes maximum, at 8.3kV phase-to-ground and 14.4kV phase-to-phase can be accomplished with proper load-break inserts and elbows.

The 25kV units are designed for use on 25kV class, 4-wire multi-grounded systems or 3-wire ungrounded systems. Elbow switching, 200 amperes maximum, at 15.2kV phase-to-ground and 26.3kV phase-to-phase can be accomplished with proper load-break inserts and elbows.

Certain inserts and elbows may lower these ratings.

Optional non-loadbreak 600 ampere bushings can be provided in lieu of 200 ampere bushing wells.



*Figure 2. The ELBOW compartment includes bushing wells for connection of (the normally customer furnished) inserts and elbows. At the top are the bushing wells for the incoming (source) circuit connections with an IN and OUT position for each phase and a parking stand between them. At the bottom are the bushing wells for the outgoing (load) circuit connections (two fuses per phase) and a parking stand is provided for each outgoing circuit.*



*Figure 3. Open door view of the FUSE compartment showing the internal, hinged and bolted barriers of NEMA grade GPO-3 red fiberglass barriers that provide isolation from energized components. Clear polycarbonate barriers are available as an option.*



*Figure 4. The FUSE compartment is pictured with the barriers secured open and showing one set of two fuses on the left phase – one fuse is latched closed and one fuse is shown in the disconnect position. The fuse mountings are non-loadbreak so the elbow has to be used to break the load current, de-energizing the circuit, before disconnecting the fuse.*

TYPE FTDF FUSED SECTIONALIZER PAD-MOUNTED SWITCHGEAR

Catalog	Fuse Type	Volts kV	Circuit Diagram	Diagram			Side	Front	Back
				A	B	C			
FTDF-115-21CL	CL	15		36	40	30			
FTDF-125-21CL	CL	25		42	50	30			
FTDF-115-21PF	PF	15		42	50	30			
FTDF-125-21PF	PF	25		50	60	36			
FTDF-115-31CL	CL	15		36	40	30			
FTDF-125-31CL	CL	25		42	50	30			
FTDF-115-31PF	PF	15		42	50	30			
FTDF-125-32PF	PF	25		50	60	36			
FTDF-115-32CL	CL	15		36	40	30			
FTDF-125-32CL	CL	25		42	50	30			
FTDF-115-32PF	PF	15		42	50	42			
FTDF-125-32PF	PF	25		50	60	48			
FTDF-115-42CL	CL	15		36	40	30			
FTDF-125-42CL	CL	25		42	50	30			
FTDF-115-42PF	PF	15		42	50	42			
FTDF-125-42PF	PF	25		50	60	48			
FTDF-315-63CL	CL	15		36	40	32			
FTDF-325-63CL	CL	25		42	50	42			
FTDF-315-63PF	PF	15		42	50	57			
FTDF-325-63PF	PF	25		50	60	72			
FTDF-315-93CL	CL	15		36	40	57			
FTDF-325-93CL	CL	25		42	50	72			
FTDF-315-93PF	PF	15		42	50	57			
FTDF-325-93PF	PF	25		50	60	72			
FTDF-315-96CL	CL	15		36	40	57			
FTDF-325-96CL	CL	25		42	50	72			
FTDF-315-96PF	PF	15		42	50	78			
FTDF-325-96PF	PF	25		50	60	84			
FTDF-315-126CL	CL	15		36	40	57			
FTDF-325-126CL	CL	25		42	50	72			
FTDF-315-126PF	PF	15		42	50	78			
FTDF-325-126PF	PF	25		50	60	84			

# TYPE FTFD FUSED SECTIONALIZER PAD-MOUNTED SWITCHGEAR

## TYPICAL – SINGLE PHASE

**FTDF - 115 - 21CL**

Shown with code 5/6 clip style fuse.

Approximate weight 320 lbs.

15 kV Class

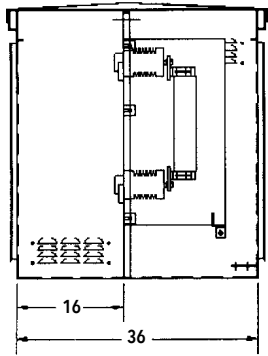

Section A-A

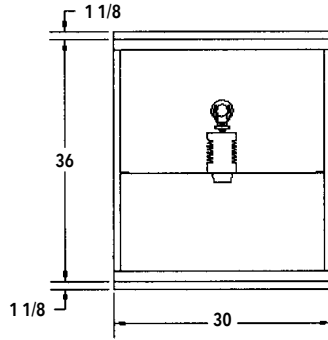

Plan View

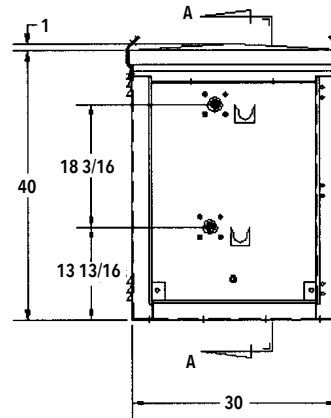

Front View - Door Removed



**FTDF - 125 - 31 - PF**

Shown with code 5/6 clip style fuse.

Approximate weight 450 lbs.

25 kV Class

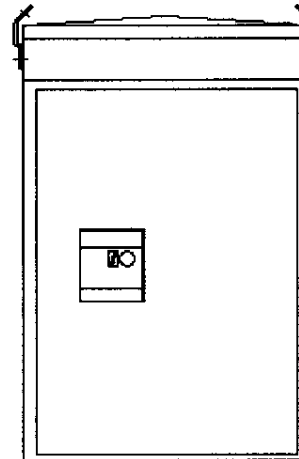

Front View  
(Typical)

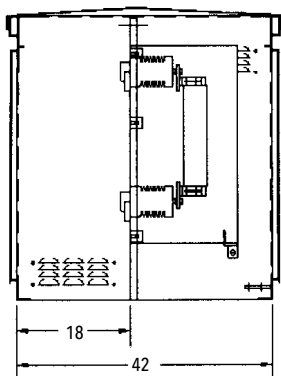

Section A-A

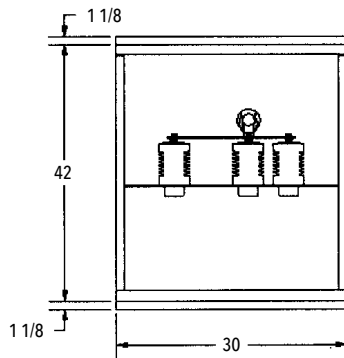

Plan View

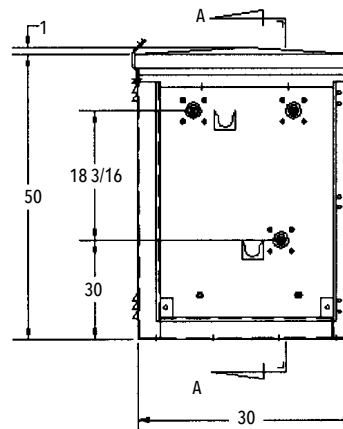

Front View - Door Removed

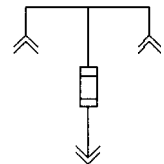

**TYPICAL – THREE PHASE**

**FTDF - 315 - 63CL**

Shown with code 5/6 clip style fuse.

Approximate weight 320 lbs.

15 kV Class

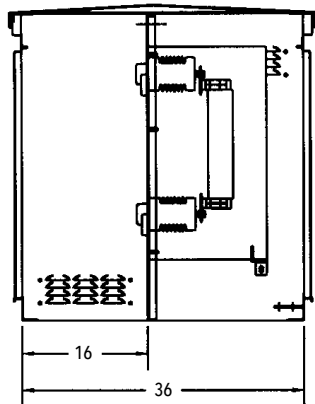

**Section A-A**

(Shown with Code 5/6 Clip Style Fuse)

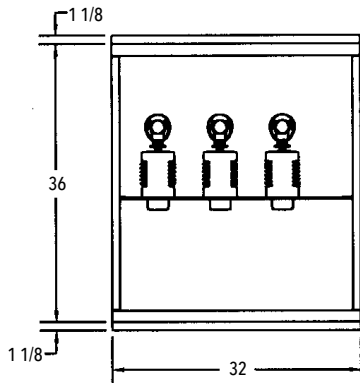

**Plan View**

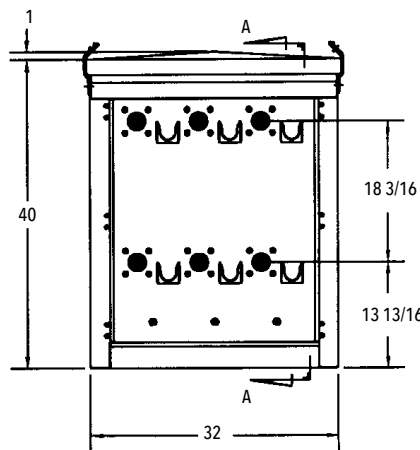

**Front View - Door Removed**

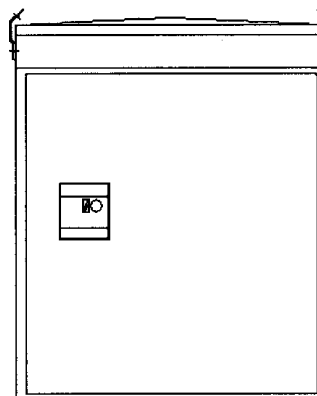

**Front View (Typical)**

**FTDF - 325 - 63CL**

Shown with code 5/6 clip style fuse.

Approximate weight 400 lbs.

25 kV Class

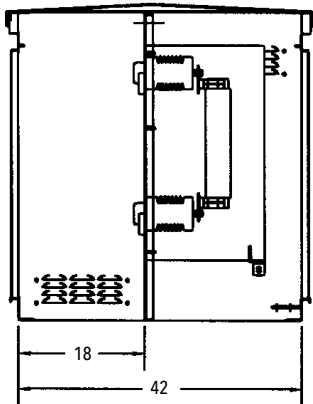

**Section A-A**

(Shown with Code 5/6 Clip Style Fuse)

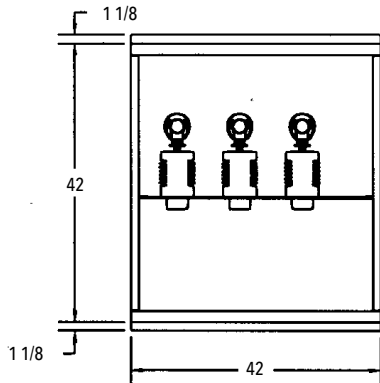

**Plan View**

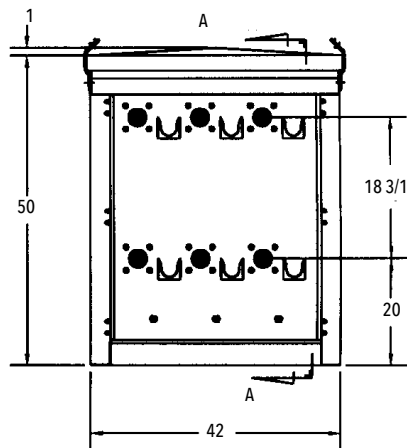

**Front View - Door Removed**

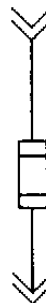

# TYPE FTDF FUSED SECTIONALIZER PAD-MOUNTED SWITCHGEAR

## TYPICAL – THREE PHASE

**FTDF - 325 - 93CL**

Shown with code 5/6 clip style fuse.

Approximate weight 680 lbs.

25 kV Class

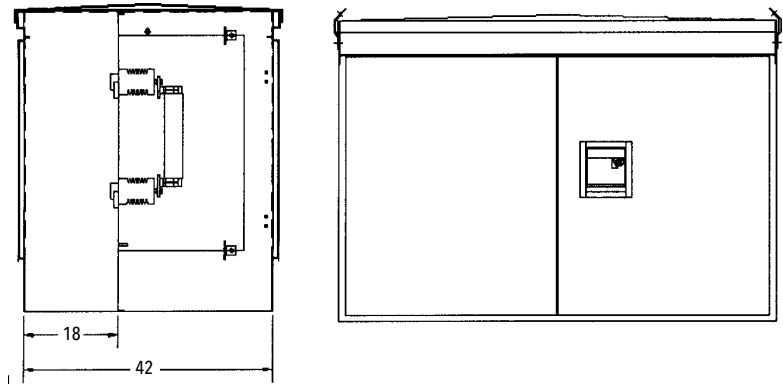
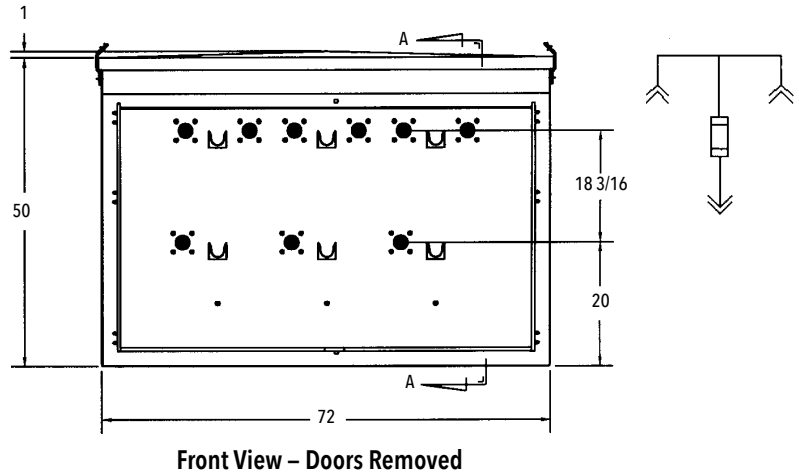
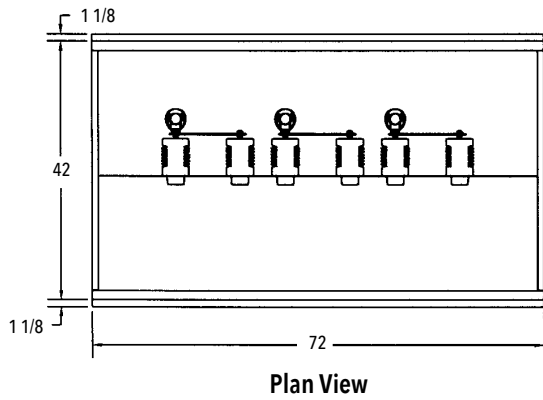

(Typical for FTDF-325-93-CL and FTDF-325-96-CL)

**FTDF - 325 - 93CL**

Shown with code 5/6 clip style fuse.

Approximate weight 720 lbs.

25 kV Class

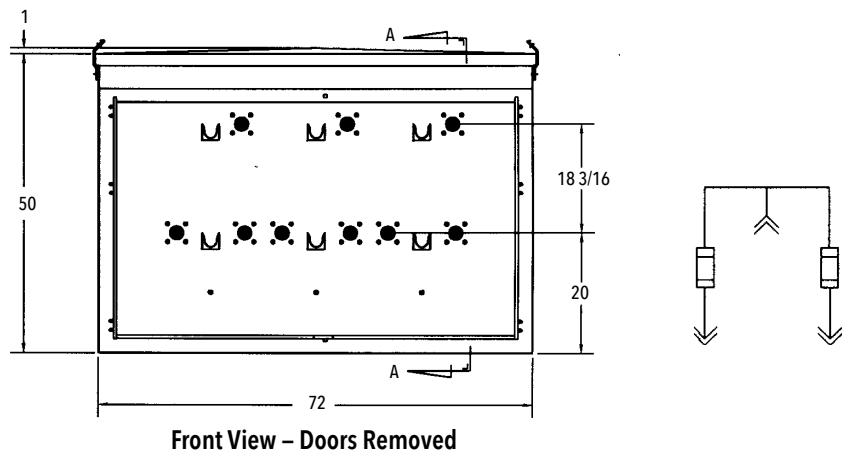
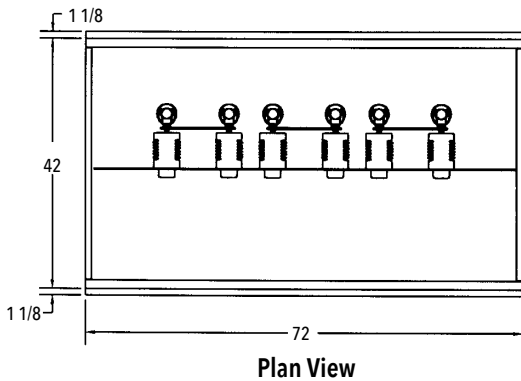

TYPICAL – THREE PHASE

FTDF - 315 - 126CL

Shown with code 5/6 clip style fuse.

Approximate weight 425 lbs.

15 kV Class

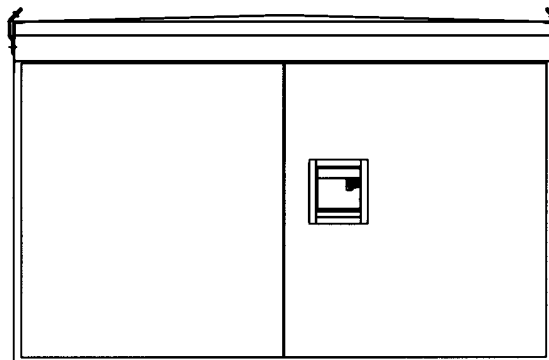
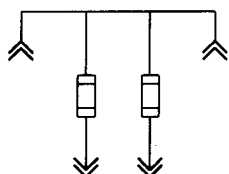
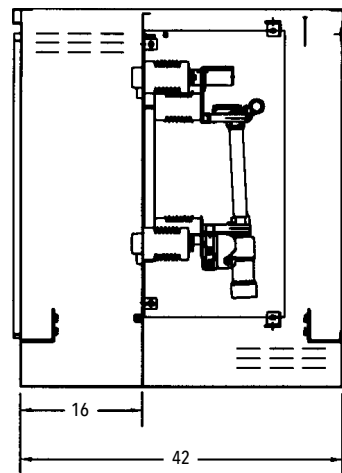
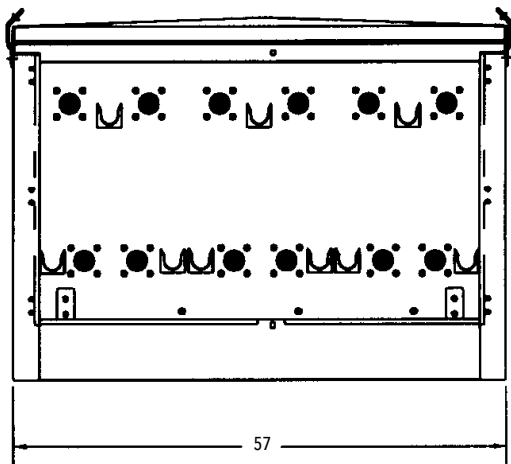
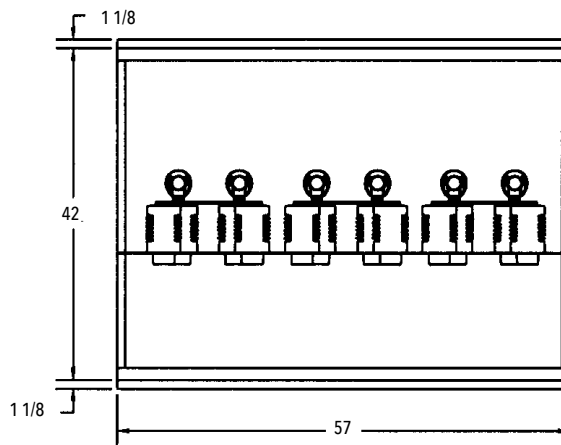
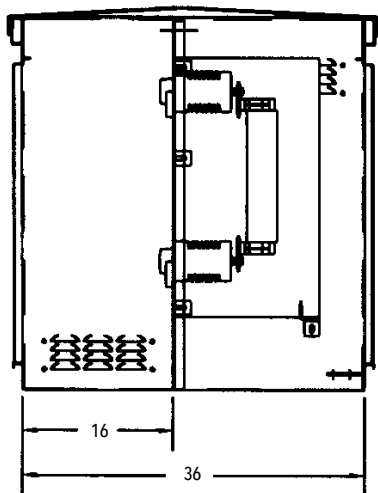

# TYPE FTDF FUSED SECTIONALIZER PAD-MOUNTED SWITCHGEAR

## TYPICAL – THREE PHASE

FTDF - 315 - 126PF

Shown with S & C SM-4Z fuses.

Approximate weight 1100 lbs.

15 kV Class

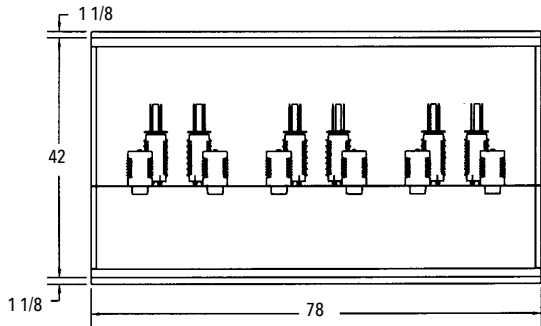

**Plan View**  
(Shown with optional 200  
Amp Line Bushing Wells)

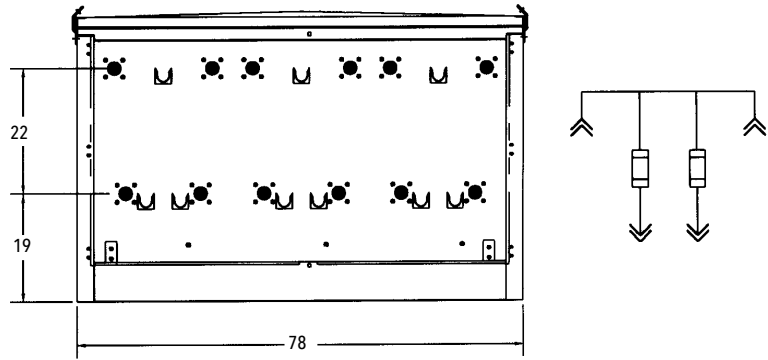

**Front View – Doors Removed**

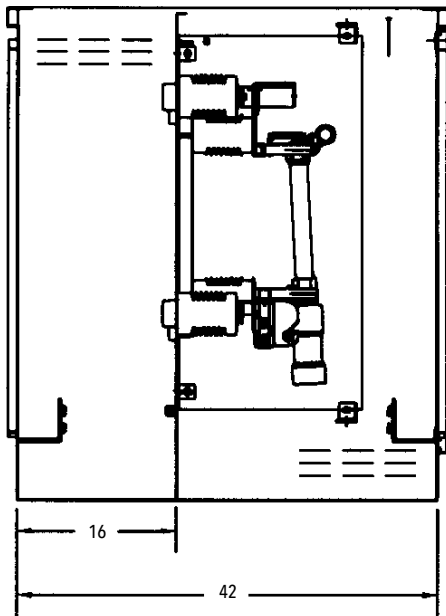

**Section A-A**  
(Shown with S&C SM-4Z Fuse  
Holders)

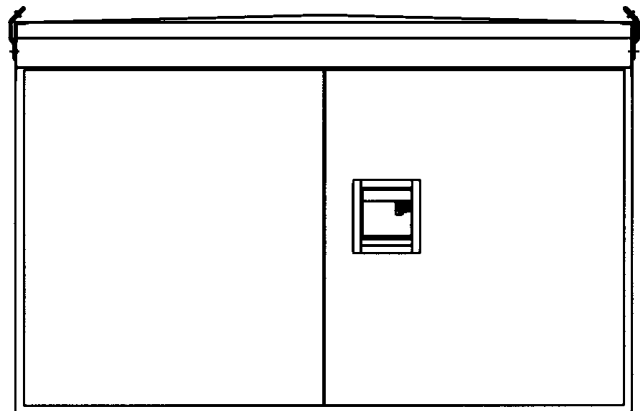

**Front View**