

# TYPE PSE MANUAL DEAD-FRONT PAD-MOUNTED SWITCHGEAR

## 15kV • 25kV • 35kV

**Air-Insulated Dead-Front Pad-Mounted Switchgear**  
**Three-Phase, Group-Operated Load-Interrupter Switches with Single-Pole, Hookstick**  
**Operated Fuses with Bushing Wells for 200-Ampere Load-Break Elbows**



**Figure 1**

*Federal Pacific Dead-Front PSE Pad-Mounted Switchgear contains an integrated system of fuses and switches with access control features to minimize exposure to high voltage during switching and re-fusing operations. 15kV and 25kV PSE designs are available as UL® Listed.*

### General

- 15kV and 25kV Type PSE Class Dead-Front Pad-Mounted Switchgear - both available as UL® Listed
- 35kV Type PSE Dead-Front Pad-Mounted Switchgear designs are not UL® Listed at this time.
- Proven Auto-jet® switching
- Meets IEEE C37.74- requirements including 3-time fault-closing on switches and fuse mountings
- 100% X-rayed cycloaliphatic epoxy insulators produced by Federal Pacific / Line Power for 15kV and 25kV applications.
- 11-gauge pickled-and-oiled steel, all welded enclosure construction. Stainless steel also available.
- A 16 gauge galvanized steel floor panel with 1" stainless-steel screened drainage provisions is standard.
- Meets ANSI C57.12.28-2005 cabinet security and enclosure finish requirements
- Stainless-steel door-handle covers and switch operating pockets
- Stainless-steel hinges and hinge pins
- Overlapping active-passive door system with 3-point auto-latch door mechanism, padlockable door handle and standard penta-head or optional hex-head security bolts
- Ventilation louvers not required in the cable compartments, but may be specified.
- Ventilation of the center medium voltage compartment is not recommended (but may be specified)
- Anti-condensation roof undercoating
- Hinged fuse panels provide visible isolation from internal bus
- NEMA Class GPO-3 non-hygroscopic fiberglass reinforced polyester barriers block access to the internal bus when the fuse panels are opened.

Federal Pacific Manual Dead-Front Type PSE Pad-Mounted Switchgear meets or exceeds all ratings in IEEE C37.74, and with UL® Listing of both 15kV and 25kV models. The 35kV design is not UL® listed at this time.

The Federal Pacific PSE enclosure design provides increased security of fuse and switch components from environmental concerns and enhanced isolation of medium-voltage circuits to limit exposure of operating personnel.

Federal Pacific PSE pad-mounts feature a low-profile, heavy-gauge enclosure with cross-kinked roof to eliminate potential for standing water. Stainless-steel hinges and hinge pins combined with the padlockable, self-resetting, three-point, auto-latch door security system assures durability while controlling access to the interior.

Double-door construction allows clear access to elbow terminations. Ground rods that are full width of door opening make grounding of circuits and installation of surge arresters easy to achieve when using a "shotgun" clampstick. Enclosure bottom flange includes gasketing to isolate and protect the finish during installation and throughout the service life of the switchgear. Galvanized-steel floor plate on bottom of compartment containing medium-voltage components isolates interior from moisture and ingress of other contaminants.

The electrostatically deposited, baked-on powder epoxy finish meets IEEE, ANSI and UL® requirements and provides a tough, durable high-gloss finish with protective qualities essential to insure long-term protection of the metal.

## TYPE PSE MANUAL DEAD-FRONT PAD-MOUNTED SWITCHGEAR



**Figure 2**

*Enclosure integrity and security is assured with Federal Pacific pad-mounted switchgear.*

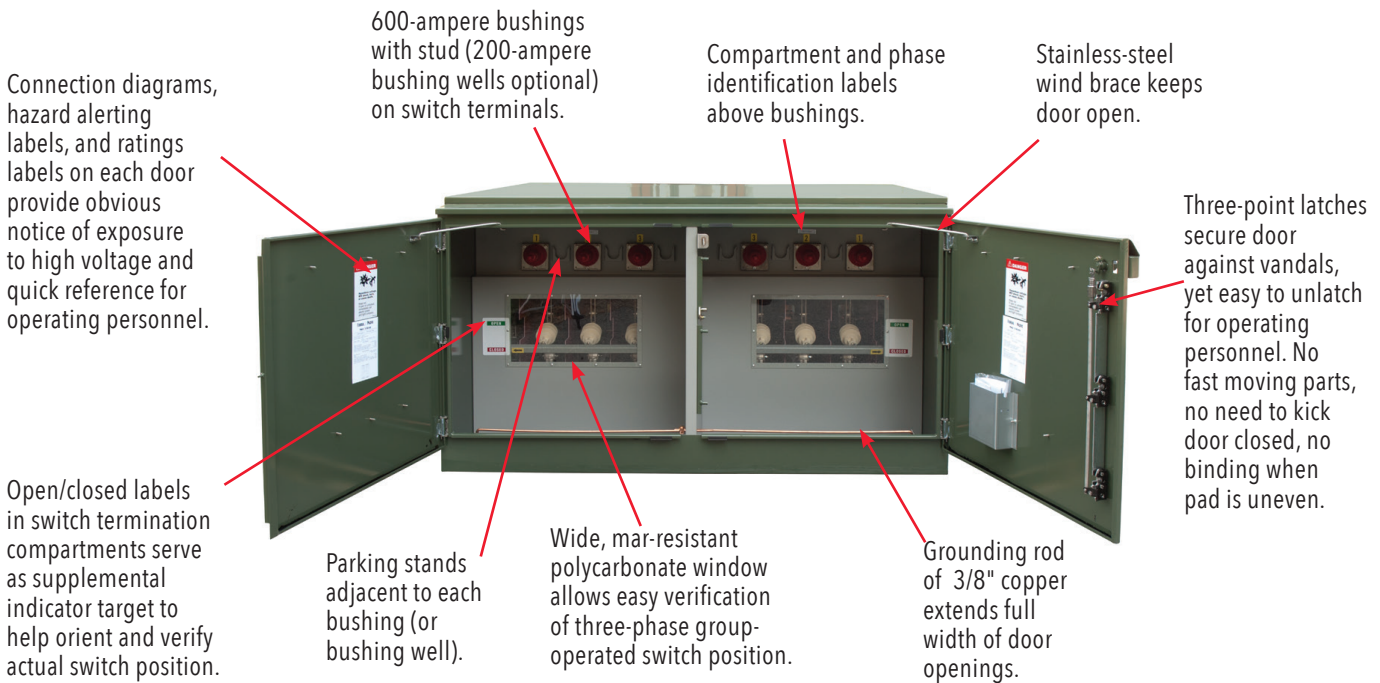

**Figure 3**

*Switch termination compartments allow visual verification of switch blade position and clear access to elbow terminations in Federal Pacific Dead-front PSE Pad-Mounted Switchgear.*

# TYPE PSE MANUAL DEAD-FRONT PAD-MOUNTED SWITCHGEAR

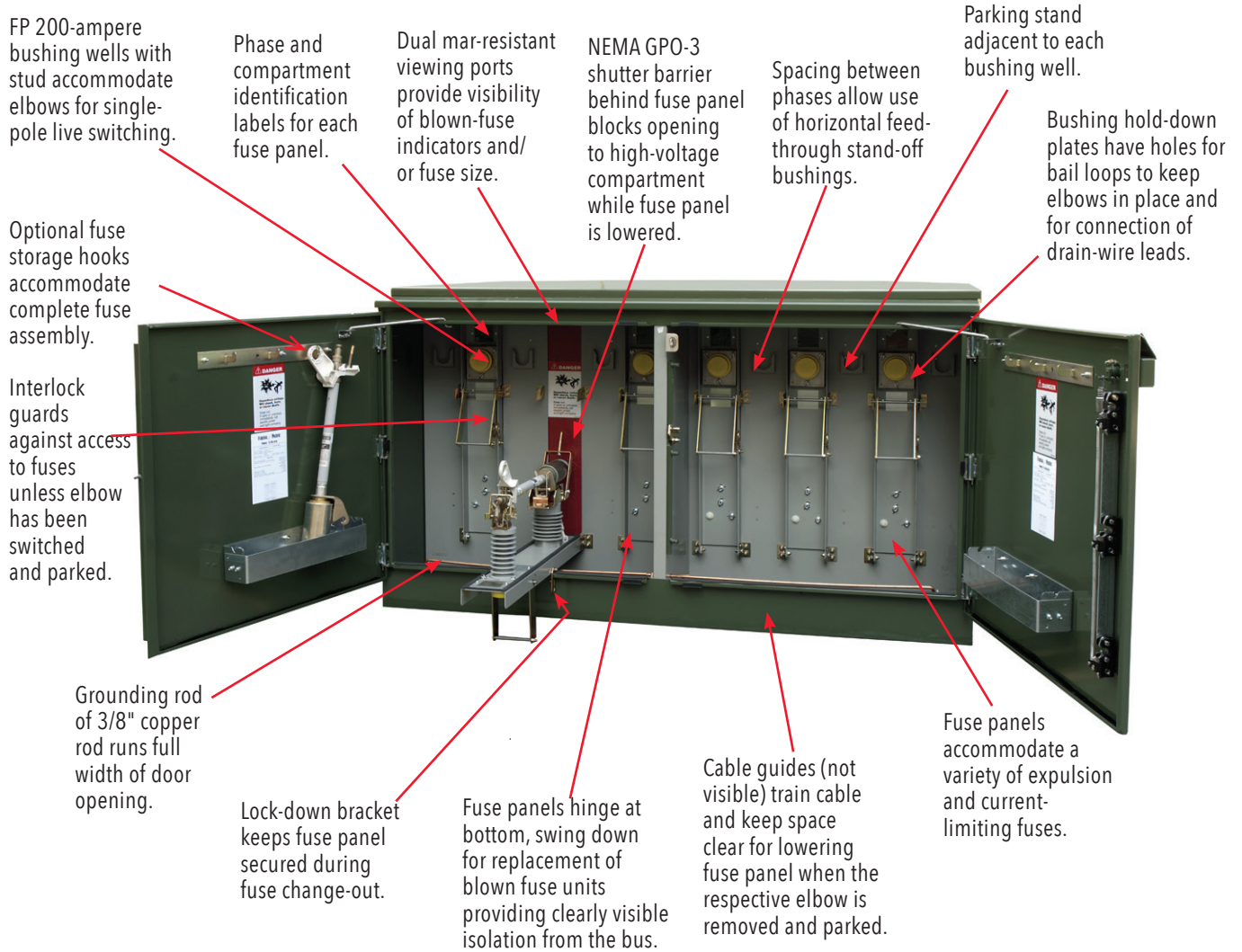

**Figure 4.** Interior view of fuse-termination compartment of Federal Pacific PSE Pad-Mounted Switchgear includes many features to assure ease of operation for operating personnel when switching, inspecting and re-fusing 200-ampere circuits.



Switch-Handle Lockbox of stainless steel and is padlockable



Switch-Operating Handle Storage



Switch-Handle Operation - handle unfolds and clip slides over joint to fix handle in extended position



Penta-head (or optional hex-head) actuated door lockbox features stainless-steel hinged padlockable cover to block access to bolt head. Rotate bolt in either direction for opening.

# TYPE PSE MANUAL DEAD-FRONT PAD-MOUNTED SWITCHGEAR

## Options for Parallel Bushings/Bushing Wells and/or Hinged Roof

### 15kV • 25kV



**Figure 5**

*Switch side of PSE-9 with optional parallel 200 Amp bushing wells in addition to the standard 600A bushings. The hinged roof option is also shown.*

### Dual Bushings and/or Bushing Wells are Available at Switch and Bus Positions

- 600A / 200A provides convenient location for arresters of personal protective grounds, without the need to connect to the back of 600A T-body elbows.
- 600A / 600A for 1200A applications or feed-through connections
- 200A / 200A parallel bushing wells are also available

**NOTE** - The dual bushing and/or bushing well options are not available at fuse positions.

### Hinged Roof

- Hinged roof options are often selected in conjunction with the dual busing option to provide more space for cable handling and terminations.
- The hinged roof option, if selected would apply to both sides of the switchgear.

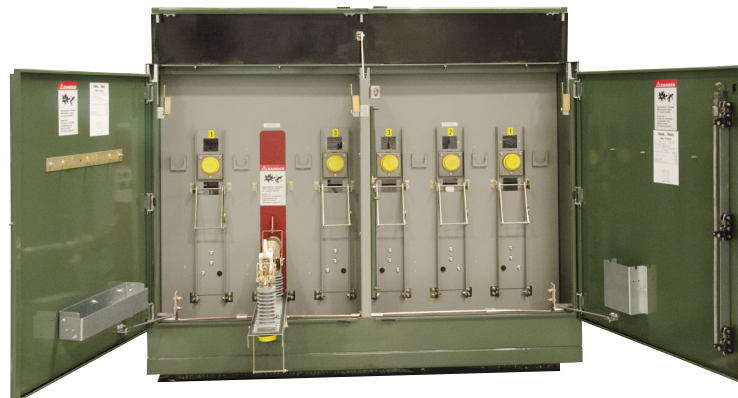

**Figure 6**

*Fuse side of PSE-9 with the hinged roof option shown.*

15kV Basic Units-Three-Phase

14.4kV Nominal • 17kV Maximum Design • 95 kV BIL  
Circuit Diagrams with Compartment Numbers

PSE Pad-Mounted Switchgear is designed for use only by qualified personnel trained to operate medium-voltage switchgear. Users other than electric utilities are required to use key interlocking devices as applicable. Should non-utility users elect not to use key interlocks, they must submit written certification that only qualified and trained personnel will operate the equipment, and that key interlock systems are not required.

Models PSE-4 and PSE-8 are available only to electric utilities.

All units are 45" high without base spacers.

To determine complete catalog number for PSE models with fuse compartments substitute for "\*" shown as last figure in catalog number listed below each diagram on this page the number shown in the following table:

1	S&C Type SM-4	3	Not applicable
2	S&C Type SMU-20	5	Cooper (M-E) Type NX
2	Eaton DBU	7	Cooper (CT) X-Limiter
2	Cooper Type CMU		

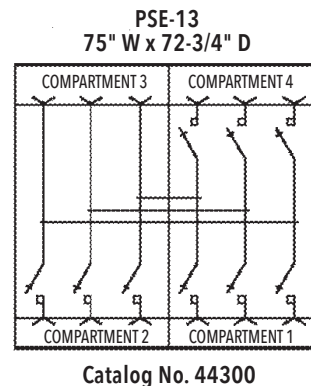
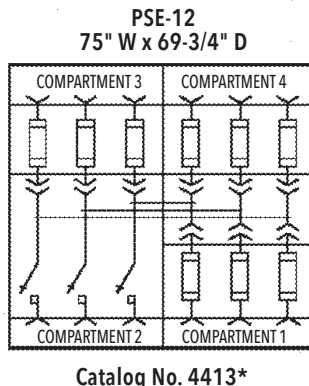
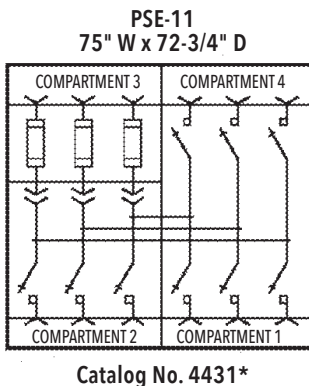
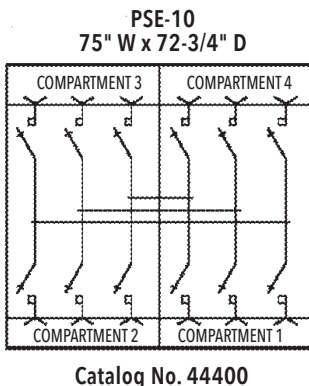
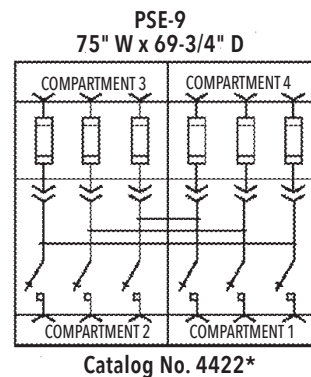
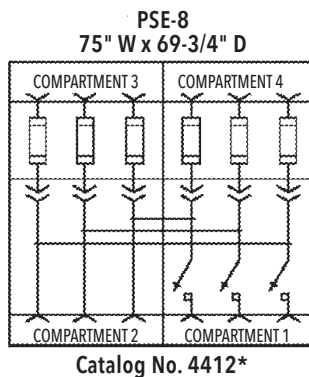
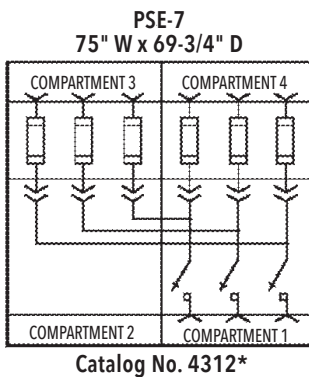
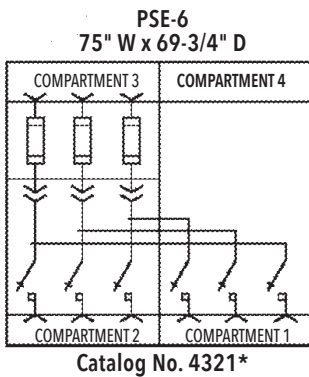
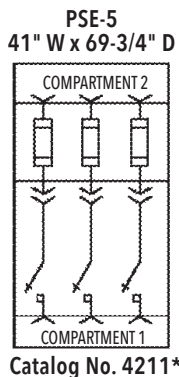
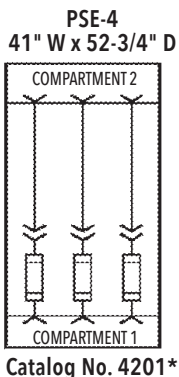
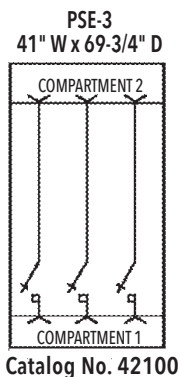

# Current Ratings - 15 kV Basic Units

## 15kV Basic Units Switch Only Units, PSE -3<sup>®</sup>, -10, -13<sup>®</sup>

Auto-jet <sup>®</sup> II Switch Ratings - Amps RMS				
Continuous Current	Load and Loop Switching	Short-Circuit Withstand Current (Sym.)	3-Time Fault-Close (Asym.) *	Peak Withstand Current
600**	600**	14,000	22,400	36,400
		25,000	40,000	65,000

\* Three-time fault close rating. The Auto-jet<sup>®</sup> switch can be closed into a fault of the magnitude specified three times and remain operable and able to carry and interrupt the rated current.

\*\*UL<sup>®</sup> Listed equipment is available at both 14kA sym./22.4kA asym and 25kA sym./40kA asym.

## Switch/Fuse Units: PSE-5, -6, -7, -8<sup>®</sup>, -9, -11, -12, -14

Fuse Manufacturer and Type ① ② ③	Unit Overall Ratings ④		Fuse Ratings	
	Amperes RMS Short Circuit		Amperes RMS	
	Momentary ASYM	MVA 3-Phase SYM at 14.4 kV	15 kV	
			Max.	Interrupting SYM ⑤
S&C SM-4	20,000	310	200	12,500
S&C SMU-20	22,400	350	200	14,000
Eaton DBU and Cooper CMU	22,400	350	200	14,000
Cooper (M-E) Type NX	40,000	620	②	50,000
Cooper (CT) X-Limiter	40,000	620	②	50,000

① SM-4 fused units require three S&C Cat. No. 86632R2 SM-4Z fuseholders and three S&C SM-4 fuse refills per fuse compartment.

SMU-20 fused units require three Federal Pacific FP-3097 and three S&C SMU-20, Eaton DBU or Cooper CMU fuse units per fuse compartment.

DBU fused units require three Federal Pacific FP-3097 end fittings and three Eaton DBU or S&C SMU-20 fuse units per fuse compartment.

NX fused units require three appropriately rated fuses per fuse compartment.

X-Limiter fused units require three appropriately rated fuses per fuse compartment.

CMU fused units require three Federal Pacific FP-3097 end fittings and three Cooper CMU, Eaton DBU or S&C SMU-20 fuse units per fuse compartment.

② For fuse application and ordering information, refer to the applicable fuse manufacturer literature.

③ SM-5 fuses cannot be used in PSE Pad-Mounted Switchgear. Contact the factory fuse-unit for alternatives.

④ Unit overall ratings are limited to the lowest component rating.

⑤ Ratings expressed in RMS amperes asymmetrical are 1.6 times the symmetrical values listed.

⑥ Default configurations, per bus termination compartment (verify with the factory when placing an order):

- PSE-3 3 - 600A Bushings
- PSE-8 3 - 200A Bushing wells
- PSE-13 3 - 200A Busings wells

All other bus termination compartment configurations must be clearly specified.

### 25kV Basic Units-Three-Phase

25kV Nominal • 27kV Maximum Design • 125 kV BIL  
Circuit Diagrams with Compartment Numbers

PSE Pad-Mounted Switchgear is designed for use only by qualified personnel trained to operate medium-voltage switchgear. Users other than electric utilities are required to use key interlocking devices as applicable. Should non-utility users elect not to use key interlocks, they must submit written certification that only qualified and trained personnel will operate the equipment, and that key interlock systems are not required.

Models PSE-4 and PSE-8 are available only to electric utilities.

All units are 51" high without base spacers.

To determine complete catalog number for PSE models with fuse compartments substitute for "★" shown as last figure in catalog number listed below each diagram on this page the number shown in the following table:

1	S&C Type SM-4	3	Not applicable
2	S&C Type SMU-20	5	Cooper (M-E) Type NX
2	Eaton DBU	7	Cooper (CT) X-Limiter
2	Cooper Type CMU		

**PSE-3**  
46" W x 81-3/4" D

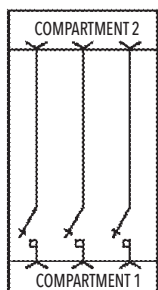

Catalog No. 52100

**PSE-4**  
46" W x 62-1/2" D

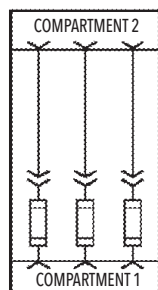

Catalog No. 5201★

**PSE-5**  
46" W x 81-3/4" D

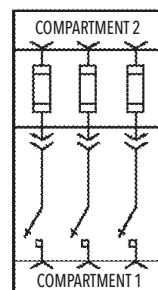

Catalog No. 5211★

**PSE-6**  
84" W x 81-3/4" D

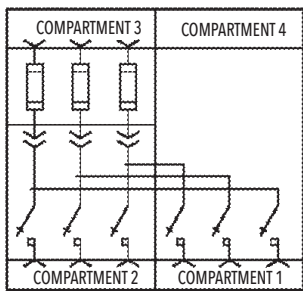

Catalog No. 5321★

**PSE-7**  
84" W x 81-3/4" D

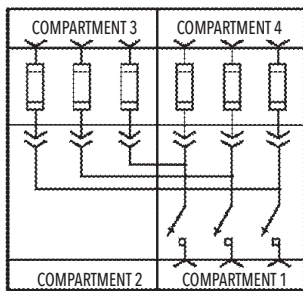

Catalog No. 5312★

**PSE-8**  
84" W x 81-3/4" D

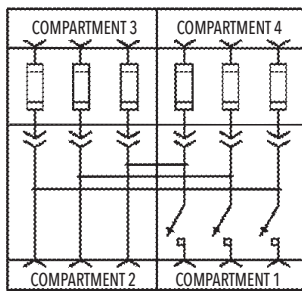

Catalog No. 5412★

**PSE-9**  
84" W x 81-3/4" D

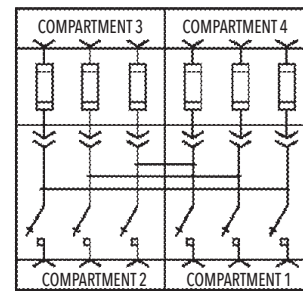

Catalog No. 5422★

**PSE-10**  
84" W x 88-1/4" D

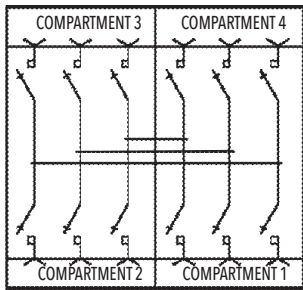

Catalog No. 54400

**PSE-11**  
84" W x 88-1/4" D

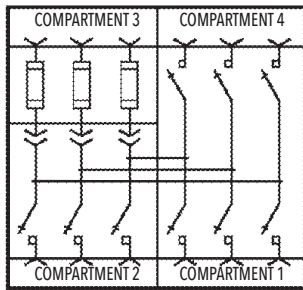

Catalog No. 5431★

**PSE-12**  
84" W x 81-3/4" D

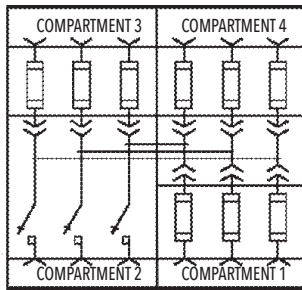

Catalog No. 5413★

**PSE-13**  
84" W x 88-1/4" D

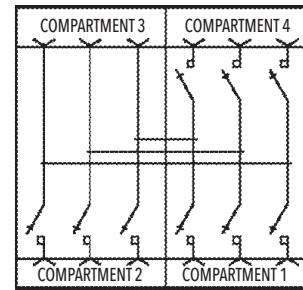

Catalog No. 54300

# Current Ratings - 25kV Basic Units

## 25kV Basic Units Switch Only Units, PSE -3<sup>Ⓣ</sup>, -10, -13<sup>Ⓣ</sup>

Auto-jet® II Switch Ratings - Amps RMS				
Continuous Current	Load and Loop Switching	Short-Circuit Withstand Current (Sym.)	3-Time Fault-Close (Asym.) *	Peak Withstand Current
600	600	12,500	20,000	32,500
		25,000**	40,000**	65,000

\* Three-time fault close rating. The Auto-jet® II switch can be closed into a fault of the magnitude specified three times and remain operable and able to carry and interrupt the rated current.

\*\*UL<sup>®</sup> Listed equipment is available at 25kA sym./40kA asym.

## Switch/Fuse Units: PSE-5, -6, -7, -8<sup>Ⓣ</sup>, -9, -11, -12, -14

Fuse Manufacturer and Type ① ② ③	Unit Overall Ratings ⑤		Fuse Ratings	
	Amperes RMS Short Circuit		Amperes RMS	
	Momentary ASYM	MVA 3-Phase SYM at 25kV	Max.	Interrupting SYM ⑥
S&C SM-4 ④	20,000	540	200	12,500
S&C SMU-20	20,000	540	200	12,500
Eaton DBU and Cooper CMU	20,000	500	200	12,500
Cooper (M-E) Type NX	40,000	1,080	②	50,000
Cooper (CT) X-Limiter	40,000	1,080	②	50,000

- ① SM-4 fused units require three S&C Cat. No. 86632R2 SM-4Z fuseholders and three S&C SM-4 fuse refills per fuse compartment.  
SMU-20 fused units require three Federal Pacific FP-3097 fuse end fittings and three S&C SMU-20, Eaton DBU or Cooper CMU fuse units per fuse compartment.  
DBU fused units require three Federal Pacific FP-3097 end fittings and three Eaton DBU, Cooper CMU or S&C SMU-20 fuse units per fuse compartment.  
NX fused units require three appropriately rated fuses per fuse compartment.  
X-Limiter fused units require three appropriately rated fuses per fuse compartment.  
CMU fused units require three Federal Pacific FP-3097 end fittings and three Cooper CMU, Eaton DBU or S&C SMU-20 fuse units per fuse compartment.
- ② For fuse application and ordering information, refer to the applicable fuse manufacturer literature.
- ③ SM-5 fuses cannot be used in PSE Pad-mounted Switchgear. Contact the factory for alternatives.
- ④ Applicable to solidly-grounded-neutral systems only with fuses connected by single-conductor, concentric-neutral type cable to a transformer or transformers. Rating is 9,400 amperes RMS symmetrical, 15,040 amperes RMS asymmetrical (405 MVA) for all other applications.
- ⑤ Unit overall ratings are limited to the lowest component rating.
- ⑥ Ratings expressed in RMS amperes asymmetrical are 1.6 times the symmetrical values listed.
- ⑦ Default configurations, per bus termination compartment (verify with the factory when placing an order):  
  - PSE-3 3 - 600A Bushings
  - PSE-8 3 - 200A Bushing wells
  - PSE-13 3 - 200A Busings wells

All other bus termination compartment configurations must be clearly specified.



### 35kV Basic Units-Three-Phase

34.5kV Nominal • 38kV Maximum Design • 150 kV BIL  
Circuit Diagrams with Compartment Numbers

PSE Pad-Mounted Switchgear is designed for use only by qualified personnel trained to operate medium-voltage (2.4kV - 34.5kV) switchgear. Users other than electric utilities are urged to use key interlocking devices as applicable. Should non-utility users elect not to use key interlocks, they must submit written certification that only qualified and trained personnel will operate the equipment, and that key interlock systems are not required.

Typical units are 69-1/4" high (including 1" crown of roof) without base spacers.

To determine complete catalog number for PSE models with fuse compartments substitute for "x" shown as last figure in catalog number listed below each diagram on this page the number shown in the following table:

⑤	S&C Type SM-4	⑤	S&C Type SM-5
2	S&C Type SMU-20	⑤	Cooper (M-E) Type NX
2	Eaton DBU	⑤	Cooper (CT) X-Limiter
⑤	Cooper Type CMU		

⑤ Not a standard offering. Contact the factory regarding availability of alternate fuse types and design.

Notes:

1. SMU-20 and DBU type fuses are available for use in 35kV nominal applications. Contact the factory for availability of other fuse designs.
2. The typical footprint for 35kV PSE-3 or PSE-5: 60"W x 108"D.
3. The typical footprint for 35kV PSE Four Compartment Units : 110"W x 108".
4. For standard two and four compartment configurations not shown, contact the factory for availability.

**PSE-3**  
60" W x 108" D x 69-1/4H

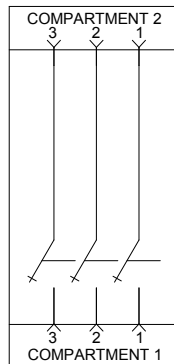

**Catalog No. 72100**  
**Typical Drawing 37-4003-002**

**PSE-5**  
60" W x 108" D x 69-1/4H

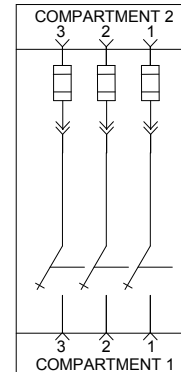

**Catalog No. 7211\***  
**Typical Drawing 37-4005-001**

**PSE-9**  
110" W x 108" D x 69-1/4H

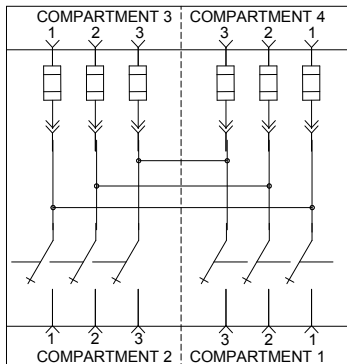

**Catalog No. 7422\***  
**Typical Drawing 37-4009-001**

**PSE-12**  
110" W x 108" D x 69-1/4H

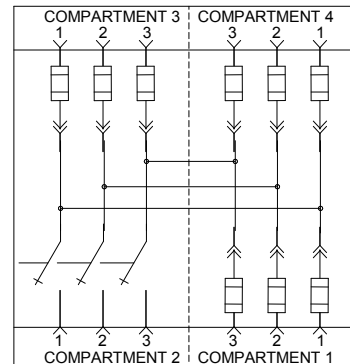

**Catalog No. 7413\***  
**Typical Drawing 37-4012-001**

# Current Ratings - 35kV Basic Units

## 35kV Basic Units ① Switch Only Units, PSE -3 ⑦

Auto-jet® Switch Ratings - Amps RMS				
Continuous Current	Load and Loop Switching	Short-Circuit Withstand Current (Sym.)	3-Time Fault-Close (Asym.) ②	Peak Withstand Current ③
600	600	25,000**	40,000	65,000

NOTE: UL® Listed equipment is not available for 35kV designs.

## Fuse Only & Switch/Fuse Units⑥: PSE-5, -9, -12

Fuse Manufacturer and Type ④ ⑤	Unit Overall Ratings Amperes RMS Short Circuit ⑥		Fuse Ratings Amperes RMS	
	Momentary ASYM ②	MVA 3-Phase SYM at 34.5kV SYM	Max.	Interrupting SYM
S&C SMU-20	13,500	500	200	8,450
Eaton DBU	12,500	500	200	8,000

NOTE: UL® Listed equipment is not available for 35kV designs.

- ① Contact the factory for the availability of additional switchgear configurations
- ② Asymmetric ratings expressed in RMS amperes asymmetrical are 1.6 times the symmetrical values listed.
- ③ Peak currents are calculated as 2.6 times the symmetrical current values listed.
- ④ For fuse application and ordering information, refer to the applicable fuse manufacturer literature.  
SMU-20 fused units require three FP-3097 fuse-unit end fittings and any three of one of the following fuse units:  
S&C SMU-20, Eaton DBU, or Cooper CMU, per fuse compartment.  
DBU fused units require three FP-3097 fuse-unit end fittings and any three of one of the following fuse units:  
S&C SMU-20, Eaton DBU or Cooper CMU, per fuse compartment.

- ⑤ Contact the factory for regarding the availability of other fuse types and designs.
- ⑥ Unit overall ratings are limited to the lowest component rating.
- ⑦ Default configurations, per bus termination compartment (verify with the factory when placing an order):

PSE-3 3 - 600A Bushings

All other bus termination compartment configurations must be clearly specified.

**Optional Features**

**BASE SPACER – MILD STEEL**

**Non-compartmented (Applicable to all models)**

- A2 ..... 6" to increase cable terminating height
- A3 ..... 12" to increase cable terminating height
- A4 ..... 18" to increase cable terminating height
- A5 ..... 24" to increase cable terminating height

**Compartmented (Applicable to all models)**

- A6 ..... 6" to increase cable terminating height
- A7 ..... 12" to increase cable terminating height
- A8 ..... 18" to increase cable terminating height
- A9 ..... 24" to increase cable terminating height

**BASE SPACER – STAINLESS STEEL**

**Non-compartmented (Applicable to all models)**

- AS2 ..... 6" to increase cable terminating height
- AS3 ..... 12" to increase cable terminating height
- AS4 ..... 18" to increase cable terminating height
- AS5 ..... 24" to increase cable terminating height

**Compartmented (Applicable to all models)**

- AS6 ..... 6" to increase cable terminating height
- AS7 ..... 12" to increase cable terminating height
- AS8 ..... 18" to increase cable terminating height
- AS9 ..... 24" to increase cable terminating height

**BASE ADAPTERS**

To order base adapters for PSE switchgear (typically when replacing equivalent PSI/II switchgear, or competitor's switchgear with similar footprints), add "99" to the equivalent base spacer shown above.

Examples:

- AS2 = 6" Stainless Steel Base Spacer.
- AS299 = 6" Stainless Steel Base Adapter.

**BUS**

- C ..... Copper Bus (main and all termination points)

**BUSHING OPTIONS**

- DB ..... Dual Bushings
- LBI ..... Loadbreak Inserts

**FUSE STORAGE HOOKS**

Hooks to hang three complete fuse assemblies on fuse-compartment door (typical applications):

- E1 ..... Compartment 3 (PSE-6, -11)
- E2 ..... Compartment 4 (Non-standard)
- E3 ..... Compartments 3 & 4 (PSE-7, 8, 9, 12)
- E4 ..... Compartment 1 (PSE-4, 12)
- E5 ..... Compartment 2 (PSE-5)
- E6 ..... Compartment 3 (PSE-6, -11)

NOTE: Fuse storage hooks may not be installed on doors with K3 or K4 interlocks.

**FINISH COLOR & SPECIAL CABINET MATERIAL**

(Applicable to all models)

- F2 ..... ANSI #61 light gray
- F3 ..... ANSI #70 sky gray
- F4 ..... Type 304 stainless-steel cabinet (exterior only)
- F5 ..... Coal Tar coating on lower three inches of enclosure or optional base spacer
- F6 ..... All Type 304 Stainless-Steel Cabinet and internal parts (or non-ferrous) hardware, except switch frame and all current-carrying parts.
- F7 ..... Same as F6 except with all stainless-steel switch except current carrying parts. (not recommended for most dead-front applications due to the protection afforded by the medium voltage compartment)

**HINGED ROOF OPTION**

- HR ..... Hinged Roof

**KEY INTERLOCKS AND SECURITY BOLTS**

Name of ultimate user, installation number and location of pad-mounted switchgear required with order.

- H ..... Hex-head security bolts in lieu of standard penta-head security bolts on all access doors. Applicable to all models.
- K1 ..... Anti-paralleling key interlocks to prevent paralleling switches in Compartments 1 & 2. Applicable to PSE-6, -9, -10, -11, -13.
- K2 ..... Provisions to padlock switch in open or closed position. All models except PSE-4.
- K3 ..... Key interlock to prevent opening fuse access door until all switches are locked open. Applicable to PSE-5, -6, -7, -8, -9, -11, -12.
- K4 ..... Anti-paralleling and fuse access key interlock to prevent paralleling of switches in Compartments 1 & 2 and to prevent opening fuse access door until all switches are locked open. Applicable to PSE-6, -9, -10, -11, -13

**CABLE SUPPORTS (Includes cable brackets) ①**

Cable supports are recommended for cables 350 MCM or larger and for all parallel cable applications.

- T3 ..... One for each switch terminal and bus terminal, accommodating #2 through 1000 kc mil conductor. Applicable to all models.
- T4 ..... One for each fuse terminal accommodating #2 through 4/0 conductor. Applicable to all models with fuse positions.

① **Cable supports extend below the base of the unit, and require the use of a cable pit or specify a minimum of 12" base spacer.**

**Pad Recommendations**

- 1) The generic (or top-level) drawings show the recommended positioning for the incoming cables at the switch and fuse terminations, as appropriate, along with the footprint of the switchgear.
- 2) The use of box pads (or equivalent) with a cable chamber or "pit" is recommended for maximum flexibility in cable installation and management.
- 3) Full or slotted openings are especially desirable for slab-on-grade installations which do not have a cable chamber or pit.

The following pad construction techniques have proven problematic and are not recommended:

Embedded ducts in poured concrete slab-on-grade installations, when the ducts are not installed in the recommended locations.  
A single duct in slab-on-grade construction for multiple phases, especially if the duct extends any appreciable distance above the pad-top.

Note – Some of these issues may be alleviated by installing a base spacer. Contact the factory for details if needed.

**FAULT INDICATOR PROVISIONS**

- T6 ..... Mounting provisions only. To accommodate one three-phase fault indicator in each switch compartment. Applicable to all models except PSE-4.
- T7 ..... Mounting provisions only with viewing window, to accommodate one three-phase fault indicator in each switch compartment with fault indicator viewing window on associated door. Applicable to all models except PSE-4.

**For LED-Type Fault Indicators and other special options, consult the factory.**

# STANDARD SPECIFICATION FOR TYPE PSE DEAD-FRONT PAD-MOUNTED SWITCHGEAR

## A. General

### 1. Product

The pad-mounted gear shall be in accordance with the applicable plans, drawings and one-line diagrams and shall conform to these specifications.

### 2. Assembly

The outdoor pad-mounted gear shall consist of a single self-supporting enclosure, containing three-phase group-operated interrupter switches and three-phase sets of single-pole fuses with the necessary accessory components, all completely factory assembled and operationally checked.

### 3. Coordination

To ensure a completely coordinated design, the pad-mounted gear shall be integrally designed and produced by the manufacturer of the basic switching equipment.

### 4. Ratings

Ratings for the integrated pad-mounted assembly shall be as designated below

System Voltage Class				
	15kV†	25kV†	35kV‡	
kV, Nominal	14.4	25	34.5	
kV, Maximum Design	17.5	27§	38	
kV, BIL	95	125	150	
Main Bus Continuous, Amps	600	600	600	
Switch Load-Interrupting, Amps	600	600	600	
Switch Fuse Load-Interrupting, Amps	200	200	200	
Switch Short-Circuit Ratings ① ②				
Amps, RMS Symmetrical	Standard	14,000	12,500	25,000
	HFC	25,000	25,000	
Peak Withstand Current, Amperes	Standard	36,400	32,500	65,000
	HFC	65,000	65,000	
MVA, 3-Phase Symmetrical at Rated Nominal Voltage	Standard	350	540	1490
	HFC	620	1,080	
Fault-Closing Amps, RMS, Asym., 3-Time Duty-Cycle③	Standard	22,400	20,000	40,000
	HFC	40,000	40,000	

① These are nominal switch ratings. Integrated pad-mounted unit may be limited by fuse ratings. Use fuse rating chart in next column to select proper short circuit ratings.

② Select one set of the ratings shown. (Standard or High Fault Current - HFC)

③ The three-time duty-cycle fault-closing rating means that the switch can be closed three times into rated fault amperes and remain operable and able to carry and interrupt its rated load current.

§Maximum design of the 27kV switch is 29kV.

†For UL® Listed units, ratings are 15.5kV, 14,000 or 25,000 amperes rms symmetrical, 350 MVA, 22,400 or 40,000 amperes fault closing; and 27kV, 25,000 amperes rms symmetrical, 1080 MVA, 40,000 amperes asymmetrical fault closing.

‡35kV class designs are not UL® Listed. Check with the factory for available configurations and footprints.

### 5. Certification of Ratings

The manufacturer shall be completely and solely responsible for the performance of the basic switch and fuse components as well as the complete integrated pad-mounted gear assembly as rated.

The manufacturer shall furnish, upon request, certification of ratings of the basic switch and fuse components and/or the integrated pad-mounted gear assembly consisting of the switch and fuse components in combination with the enclosure. This certification of the integrated unit shall include testing the pad-mounted gear to the fault-close requirements of the specification to assure the bus support system and components are adequate.

Fuse Ratings				
Fuse Manufacturer	Fuse Type	Three-Phase MVA Sym.	Amps RMS Asym. ①	Cont. Amps
<b>14.4 kV Nominal Voltage</b>				
S&C ④	SM-4	310	20000	200
S&C	SMU-20	350	22400	200
S&C ③	SM-5‡	-	-	-
Eaton	DBU	350	22400	200
Cooper④	CMU	350	22400	200
Cooper (M-E)②	NX	620	40000	100*
Cooper (CT)②	X-Limiter	620	40000	140
Thomas & Betts ②③	Hi-Tech	620	40000	140
<b>25 kV Nominal Voltage</b>				
S&C ④	SM-4†	540	20000	200
S&C	SMU-20	540	20000	200
S&C ③	SM-5‡	-	-	-
Eaton	DBU	500	20000	200
Cooper ④	CMU	500	20000	200
Cooper (M-E)②	NX	1080	40000 ③	40
Cooper (CT)②	X-Limiter	1080	40000 ③	40
Thomas & Betts ②③	Hi-Tech	1080	40000 ③	50
<b>34.5 kV Nominal Voltage ⑤</b>				
S&C	SMU-20	500	13500	200
Eaton	DBU	500	12500	200

① The fuse mounting can withstand rated fault amperes up to three times and remain operable and able to carry its rated load current. For rating applicable to fault-closing capability of the separable connector (elbow), refer to elbow manufacturer.

② Maximum current rating of the fuse mounting is 22,400 amperes rms asymmetrical. Fuse mounting ratings can be increased to the fuse-interrupting rating ONLY if the current-limiting fuse limits the let-through current to a value equal to or less than the short-circuit rating of the fuse mounting. Refer to current-limiting fuse manufacturer.

③ Models with this fuse-type are not UL® Listed.

④ Check with the factory for UL® Listing.

⑤ 35kV class designs are not UL® Listed.

\* 100 amp @ 13.5 kV max or 80 amp @ 15 kV.

† Applicable to solidly-grounded-neutral systems only with fuses connected by a single conductor concentric neutral type cable to a transformer or transformers. Rating is 9,400 amperes RMS symmetrical, 15,000 amperes RMS asymmetrical (405 MVA symmetrical) for all other applications.

‡ SM-5 fuses cannot be used in PSE Pad-mounted Switchgear. Contact factory for SM-5 applications.

The following optional feature may be specified:

- a) The pad-mounted switchgear shall be UL® Listed.

### 6. Submittals

When requested, the manufacturer shall furnish the following drawings and reports:

- a) Layout showing dimensions, arrangements, electrical ratings, components and weights.
- b) Certified test reports of similar manufactured units showing fault-closing capability and load-interrupting capability of switches and complete pad-mounted gear assembly based on maximum design voltage.

### 7. Compliance with Standards & Codes

The pad-mounted switchgear shall conform to or exceed the applicable requirements of the following standards and codes:

- a) All portions of ANSI/IEEE C57.12.28, covering enclosure integrity for pad-mounted equipment.

- b) Article 490.21(E) "Load Interrupters" in the National Electrical Code, which specifies that the interrupter switches in combination with power fuses shall safely withstand the effects of closing, carrying, and interrupting all possible currents up to the assigned maximum short-circuit rating.
- c) All portions of IEEE C37.74 covering design and testing of the distribution switchgear, components and ways.
- d) All portions of ANSI, IEEE, and NEMA standards applicable to the basic switch and fuse components.

**8. Enclosure Design**

To ensure a completely coordinated design, the pad-mounted gear shall be constructed in accordance with the minimum construction specifications of the fuse and/or switch manufacturer to provide adequate electrical clearances and adequate space for fuse handling.

In establishing the requirements for the enclosure design, consideration shall be given to all relevant factors such as controlled access and tamper resistance.

**B. Construction - Assembly**

**1. Insulators, Bushings and Bushing Wells**

The interrupter-switch and fuse-mounting insulators and the bushings and bushing wells shall have the following material characteristics and restrictions:

- a) Operating experience of at least twenty (20) years under similar conditions.
- b) Ablative action to ensure non-tracking properties.
- c) Adequate leakage distance established by test per IEC Standard 60507.
- d) Adequate strength for short-circuit stress established by test.
- e) Conformance with applicable ANSI standards.
- f) Homogeneity of the cycloaliphatic epoxy resin throughout each insulator, bushing and bushing well to provide maximum resistance to power arcs. Ablation due to high temperature from power arcs shall continuously expose more material of the same composition and properties so that no change in mechanical or electrical characteristics takes place because of arc-induced ablation. Furthermore, any surface damage to insulating components during installation or maintenance of the pad-mounted gear shall expose material of the same composition and properties so that insulating components with minor surface damage need not be replaced.
- g) Each insulator, bushing and bushing well shall be x-rayed to assure it is essentially void free. An alternate testing method may be used only by approval of the engineer.
- h) Conductor rods of bushings and bushing wells shall be of all copper with silver flash at threaded studs.

**2. High-Voltage Bus**

- a) Bus and interconnections shall consist of bare aluminum bar of 56% IACS conductivity with an oxide-inhibiting agent at all bus joints.
- b) Bus and interconnections shall withstand the stresses associated with short circuits up through the maximum rating of the pad-mounted gear, including proper allowance for transient conditions.
- c) Bolted aluminum-to-aluminum connections shall be made with a suitable number of non-corrosive bolts and with two Belleville spring washers per bolt, one under the bolt head and one under the nut, or with a wide, flange-head bolt and one Belleville spring washer under the nut per bolt. As an

alternate, bolted aluminum-to-aluminum connections shall be made with a suitable equivalent surface area, i. e. 1-bolt and spring washer. Bolts shall be tightened to an appropriate torque to assure good electrical connection.

- d) Before installation of the bus, all electrical contact surfaces shall first be prepared by abrading to remove any aluminum-oxide film. Immediately after this operation, the electrical contact surfaces shall be coated with a uniform coating of an oxide inhibitor and sealant.

**3. Ground-Connection Pads**

- a) A ground connection pad shall be provided in each termination compartment of the pad-mounted gear.
- b) The ground connection pad shall be constructed of 1/4" thick, stainless steel and have a NEMA 2-hole pattern for ground connections. The pad shall be welded to the enclosure and shall have a short-circuit rating equal to that of the integrated assembly.
- c) A full width copper grounding rod shall be provided in each cable-termination compartment.

**C. Construction - Enclosure & Finish**

**1. Enclosure**

- a) The pad-mounted enclosure shall be of unitized construction (not structural frame and bolted sheet) to maximize strength, minimize weight, and inhibit internal corrosion.
  - b) The basic material for the enclosure, roof and doors shall be 11-gauge, hot-rolled, pickled-and-oiled steel sheet.
  - c) All structural joints and butt joints shall be welded, and the external seams shall be ground flush and smooth. A welding process shall be employed that eliminates alkaline residues and minimizes distortion and spatter.
  - d) To guard against unauthorized or inadvertent entry, enclosure construction shall not utilize any externally accessible hardware.
  - e) The base shall consist of continuous 90-degree flanges, turned inward and welded at the corners, for bolting to the concrete pad.
  - f) The door openings shall have 90-degree flanges, facing outward, that shall provide strength and rigidity as well as deep overlapping between doors and door openings to guard against water entry.
  - g) In consideration of tamper resistance, the enclosure shall conform to or exceed the requirements of ANSI/IEEE C57.12.28.
  - h) A heavy coat of insulating "no-drip" compound shall be applied to the inside surface of the roof to reduce condensation of moisture thereon. The roof shall be removable with bolts accessible in termination compartments.
  - i) Lifting tabs shall be removable. Sockets for the lifting-tab bolts shall be blind-tapped. A protective material shall be placed between the lifting tabs and the enclosure to prevent the tabs from scratching the enclosure finish. This material shall be non-hygroscopic to prevent moisture from being absorbed.
  - j) To prevent moisture ingress, the roof shall be one-piece construction and shall not include any gasketed joints or any unground weld butt joints exposed to the exterior.
- The following optional feature may be specified:**
- k) A steel (specify compartmented or non-compartmented) base spacer shall be provided to increase the elevation of live parts in the pad-mounted gear above the mounting pad by (specify 6, 12, 18, 24) inches.

## 2. Barrier Assembly

Insulating barriers shall be provided in each switch and fuse compartment as required to achieve necessary insulation levels. This barrier system shall be constructed of fiberglass reinforced polyester (NEMA rated GPO-3).

## 3. Doors

- a) Doors shall be constructed of 11-gauge hot-rolled, pickled-and-oiled steel sheet.
- b) Door edge flanges shall overlap with door opening flanges and shall be formed to create a mechanical maze that shall guard against water entry or discourage tampering or insertion of foreign objects.
- c) Doors shall have a minimum of three stainless steel hinges and hinge pins. The hinge pins shall be secured in place to guard against tampering.
- d) One active and one passive door shall be provided. In consideration of controlled access and tamper resistance, each active door shall be equipped with a positive-action three-point auto-latch mechanism and padlock hasp.
- e) Each active door shall be provided with a hinged stainless-steel cover over the operating bolt. The cover shall be padlockable and shall incorporate a hood to protect the padlock shackle from tampering and access to the operating bolt. Each handle shall be provided with a recessed penta-head (hex optional) bolt for additional security.
- f) Each passive door shall be independently secured and latched to the enclosure and shall not require a tool for opening.
- g) Doors providing access to fuses shall have provisions to store spare expulsion type fuse units or refills.
- h) Each door shall be provided with a stainless-steel door holder located above the door opening. These holders shall be hidden from view when the door is closed. It shall not be possible for the holders to swing inside the enclosure.

## 4. Finish

- a) Full coverage at joints and blind areas shall be achieved by processing enclosures independently of components such as doors and roofs before assembly into the unitized structures.
- b) All exterior seams shall be sanded or ground smooth for neat appearance.
- c) All surfaces shall undergo a chemical cleaning, phosphatizing or zirconization and sealing process before any protective coatings are applied in order to remove oils and dirt, form a chemically and anodically neutral conversion coating, improve the finish-to-metal bond, and retard underfilm propagation of corrosion.
- d) The finishing system shall be applied without sags or runs.
- e) After the enclosure is completely assembled and the components (switches, bus, etc.) are installed, the finish shall be inspected for scuffs and scratches.
- f) Blemishes shall be carefully touched up by hand to restore the protective integrity of the finish.
- g) Unless otherwise specified, the color shall be Munsell No. 7GY3.29/1.5, dark green.
- h) To ensure that the finishing system is capable of resisting corrosion, the manufacturer shall provide on request, certification that representative test panels, protected by the manufacturer's finish system, have passed the coating system performance

requirements in section 5.5 of ANSI C57.12.28 as verified by an independent third party certifier, such as UL\*.

## D. Basic Components

### 1. Interrupter Switches

- a) Interrupter switches shall have a three-time duty-cycle fault-closing rating equal to or exceeding the short circuit rating of the integrated pad-mounted gear assembly. These ratings define the ability to close the interrupter switch either alone (unfused) or in combination with the appropriate power fuses three times against a three-phase fault with asymmetrical current in at least one phase equal to the rated value, with the switch remaining operable and able to carry and interrupt rated current. Tests substantiating these ratings shall be performed at maximum design voltage with current applied for at least 10 cycles. Certified test abstracts establishing such ratings shall be furnished upon request.
- b) Interrupter switches shall utilize a quick-make, quick-break mechanism installed by the switch manufacturer. The quick-make, quick-break mechanism shall be integrally mounted on the switch frame, and shall swiftly and positively open and close the interrupter switch independent of the speed of the switch operating handle.
- c) Interrupter switches shall be operated by means of an externally accessible switch-operating hub. The switch-operating hub shall be located within a recessed stainless-steel pocket mounted on the side of the pad-mounted enclosure. The switch-operating hub pocket shall include a padlockable stainless-steel access cover that shall incorporate a hood to protect the padlock shackle from tampering. Labels or targets to indicate switch positions shall be provided in the switch operating hub pocket.
- d) Each interrupter switch shall be completely assembled and adjusted by the switch manufacturer on a rigid mounting frame. The frame shall be of heavy-gauge steel construction.
- e) Interrupter switch shall be provided with contact blades and interrupters for circuit closing, including fault-closing, continuous current carrying, and circuit interrupting. Spring loaded auxiliary blades shall not be permitted.
- f) Circuit interruption shall be accomplished by use of an interrupter which is positively and inherently sequenced with the blade position. It shall not be possible for the blade and interrupter to get out of sequence.
- g) Interrupter switches shall have a readily visible open gap when in the open position, which shall be viewable through a mar-resistant clear barrier, to allow positive verification of correct switch position. In addition, an open/close label shall be provided in the termination compartment to give a supplemental visual indication of switch position.
- h) Each interrupter switch shall be provided with a switch operating handle. The switch-operating handle shall be secured to the inside of the switch-operating hub pocket and shall be stored behind the switch-operating hub access cover.
  - i) To increase contact separation speed, interrupter switch contacts on both sides of the arcing area shall be spring assisted to reduce arcing time and to rapidly increase the dielectric gap.
  - j) To further insure arc extinction, air shall be compressed and simultaneously injected into the arcing area to cool the arc and thereby not rely solely on blade travel to insure arc extinction.
  - k) Arc extinction shall not rely on gases generated by ablative action of the arc playing on any interrupter switch components or materials which will carbonize, deplete or otherwise erode such components and materials.

**The following optional features may be specified:**

- l) Key interlocks shall be provided to prevent paralleling the two source interrupter switches.
- m) Key interlocks shall be provided to guard against opening fuse compartment door(s) unless all switches (series tap switch only, where furnished) are locked open.
- n) Provision to padlock switch-operating hub in open or closed position shall be provided.
- o) Cable guides shall be provided to help orient cables at switch and bus compartment terminals.
- p) Mounting provisions shall be provided to accommodate one three-phase fault indicator with three single-phase sensors in each switch compartment (except series tap switch, where furnished). External holes for fault indicators shall include a tamper-resistant arrangement where fault indicators are not shipped installed.
- q) Mounting provisions to accommodate LED-Type Fault Indicators. Holes for such fault indicators shall be plugged for shipment with tamper-resistant arrangement.
- r) To facilitate installation of elbow-connected surge arresters or grounding elbows, a set of three 200-ampere bushing wells shall be provided in each switch-termination compartment without increasing the height or depth of the basic unit.
- s) Cable supports - recommended for cables 350MCM or larger and for all parallel cable applications.

**2. Switch Compartments**

- a) Switch terminals shall be equipped with 600 ampere rated bushings that include removable silver-plated copper threaded studs to accommodate a choice of termination systems.
- b) Bushings and bushing wells shall have interfaces in accordance with ANSI/IEEE Standard 386 (ANSI Standard C119.2) to accept all standard separable insulated connectors and inserts.
- c) Parking stands are provided adjacent to each bushing and bushing well to accommodate horizontal feed-throughs and standoff insulators.
- d) All medium-voltage switch and fuse components are completely encased in an inner grounded steel compartment. The component compartment floor shall be of 16-gauge galvanized steel sheet to exclude foliage and animals. The floor shall be cross-kinked and shall have a small stainless-steel screen in each corner.
- e) Viewing windows are provided within the termination compartments to allow visual verification of switch position, observation of switch-position open/close labels and inspection of blown-fuse indicators on power fuses.

**3. Fuse Compartments**

- a) Fuse terminals are equipped with 200 ampere rated bushing wells designed to accept 200 ampere bushing inserts and shall have removable, silver-plated copper studs.
- b) Bushings and bushing wells shall have interfaces in accordance with ANSI/IEEE Standard 386 (ANSI Standard C119.2) to accept all standard separable insulated connectors and inserts. Parking stands are provided adjacent to each bushing and bushing well to accommodate horizontal feed-throughs and standoff insulators.
- c) Fuse access panels shall have a mechanical interlock that guards against gaining access to the fuse before opening the load-break separable insulated connector at the fuse terminal.

- d) The fuse shall be accessible only when de-energized and isolated – for full-view non-loadbreak disconnection and removal with a shotgun stick. This mounting features positive latching in both the energized and de-energized positions. When latched in the open position, the de-energized fuse is electrically isolated and readily accessible to operating personnel for removal with full visibility of contact interfaces on both sides of the fuse.
- e) Access to the compartment containing energized components when fuses are being changed shall be blocked by a GPO-3 panel that is secured in position.
- f) Individual parking stands shall be provided for each fuse mounting to allow convenient installation of elbow accessories to accommodate grounding. A ground rod shall be installed across the full width of the fuse compartments for connecting of cable concentric neutrals. Fuse phases shall be equipped with cable guides to assist in cable training and to prevent cables from interfering with movement of the fuse-access panel.
- g) To provide maximum service life and to prevent corrosion of moving parts, all latches and pivots in the fuse-handling mechanism shall be either painted steel, stainless steel, or zinc-plated.

**The following optional features may be specified:**

- h) Fuse storage hooks shall be provided on fuse-termination compartment access door(s). Each set of hooks shall allow the storing of three complete fuse assemblies for power fuses. Storage hooks shall be for two holders when current-limiting fuses are used.

**4. Bus Termination Compartments**

- a) PSE dead-front bus termination compartments may be equipped with 200A bushing wells and/or 600A dead-break bushings.
- b) Default configurations, per bus termination compartment (verify with the factory when placing an order):
  - PSE-3 3 - 600A Bushings
  - PSE-8 3 - 200A Bushing wells
  - PSE-13 3 - 200A Bushing wells
- c) All other bus termination compartment configurations must be clearly specified.

**E. Labeling**

**1. Warning Signs**

All external doors shall be provided with approved "WARNING – HIGH VOLTAGE – KEEP OUT" signs.

**2. Nameplate, Ratings Labels & Connection Diagrams**

- a) The outside of both the front and back shall be provided with nameplates indicating the manufacturer's name, catalog number, model number, and date of manufacture.
- b) The inside of each door shall be provided with a ratings label indicating the following: voltage ratings; main bus continuous rating; short-circuit ratings (amperes, RMS symmetrical and MVA three-phase symmetrical at rated nominal voltage); the type of fuse and its ratings including duty-cycle fault-closing capability; and interrupter switch ratings, including duty-cycle fault-closing capability and amperes, short-time, RMS (momentary asymmetrical and one-second symmetrical). A label indicating equipment is UL<sup>®</sup> Listed shall be included when applicable.
- c) A three-line connection diagram showing interrupter switches, fuses and bus along with the manufacturer's model number shall be provided on the inside of both the front and rear doors, and on the inside of each switch-operating hub access cover.

### **F. Accessories**

End fittings or holders, and fuse units or refill units for original installation, as well as spare fuse unit or refill unit for each fuse mounting, shall be furnished in accordance with the client's requirements when specified.