

600/900 A, 15/25 kV Class BOL-T deadbreak connector



General

Eaton terminates high-voltage underground cable on deadfront apparatus such as transformers, switches, and switchgear with its Cooper Power™ series 600/900 A, 15/25 kV Class BOL-T™ deadbreak connector. It is fully shielded and submersible and meets the requirements of IEEE® Std 386™-2016—“Separable Insulated Connector Systems.”

The capacitive test point on the insulating plug provides a means of testing the circuit without disturbing the bolted connection.

In addition to the capacitive test point feature on the insulating plug, Eaton offers an optional capacitive test point similar to its Cooper Power series 200 A elbows. This allows the use of the Type “TPR” faulted circuit indicators and provides a hotstick operable means of determining circuit condition when used with high-impedance voltage sensing devices designed for test points.

The BOL-T is rated to 600 A continuous current when used with aluminum connectors. It is rated to 900 A or a shear bolt are selected using the catalog numbering system.

BOL-T connectors are designed for use on solid dielectric cable (XLPE or EPR) with extruded semi-conductive shields and concentric neutral, with or without a jacket.

Installation on jacketed concentric neutral cable may require additional sealing material. Cold shrinkable adapters are available for tape shield, linear corrugated and drain wire cable adaptation for use with deadbreak connectors.

900 A rating

The BOLT connector is rated for 900 A continuous when used with a coppertop compression connector or shear bolt, copper insulating plug, copper stud, and copper bushing or junction. If a 900 A rating is desired, specify a "C" as the 10th digit when determining the part number. See **Step 3 on page 5**.

Interchangeability

Eaton's Cooper Power series 600 A deadbreak connectors conform to the electrical, mechanical, and dimensional requirements of IEEE Std 386-2016. The connectors can be used on any comparably rated bushing interface that also meets the requirements of this standard. In addition, all cable adapters, insulating plugs, compression connectors, and other component parts are designed to be interchangeable with those currently available from other major manufacturers that also comply with IEEE Std 386-2016.

Installation

A torque wrench and 1-inch socket are used to tighten the insulating plug through the compression or shear bolt connector within the T-body onto a de-energized 600 A bushing interface. Refer to *Service Information MN650005EN 600 A 15/25 kV Class BOLT and Separable Splice Connector Assembly Installation Instructions* for details.

Production tests

Tests conducted in accordance with IEEE Std 386-2016:

- ac 60 Hz 1-minute withstand
 - 40 kV
- Minimum partial discharge extinction voltage
 - 19 kV

Tests conducted in accordance with Eaton requirements:

- Physical inspection
- Periodic dissection
- Periodic X-ray analysis

Table 1. Voltage ratings and characteristics

Description	kV
Standard voltage class	25
Maximum rating phase-to-ground	15.2
ac 60 Hz 1-minute withstand	40
dc 15-minute withstand	78
BIL and full wave crest	125
Minimum partial discharge extinction voltage	19

Note: Voltage ratings and characteristics are in accordance with IEEE Std 386-2016.

Table 2. Current ratings and characteristics

Description	Amperes	
Continuous	600 A rms (aluminum)	900 A rms (copper or shear bolt)
4-hour overload	900 A rms (aluminum)	1200 A rms (copper or shear bolt)
Short time (aluminum)	40,000 A rms symmetrical for 0.17 s	
	27,000 A rms symmetrical for 4 s	
Short time (copper or shear bolt)	40,000 A rms symmetrical for 0.17 s	
	27,000 A rms symmetrical for 4 s	

Note: Current ratings and characteristics are in accordance with IEEE Std 386-2016.

Features and benefits

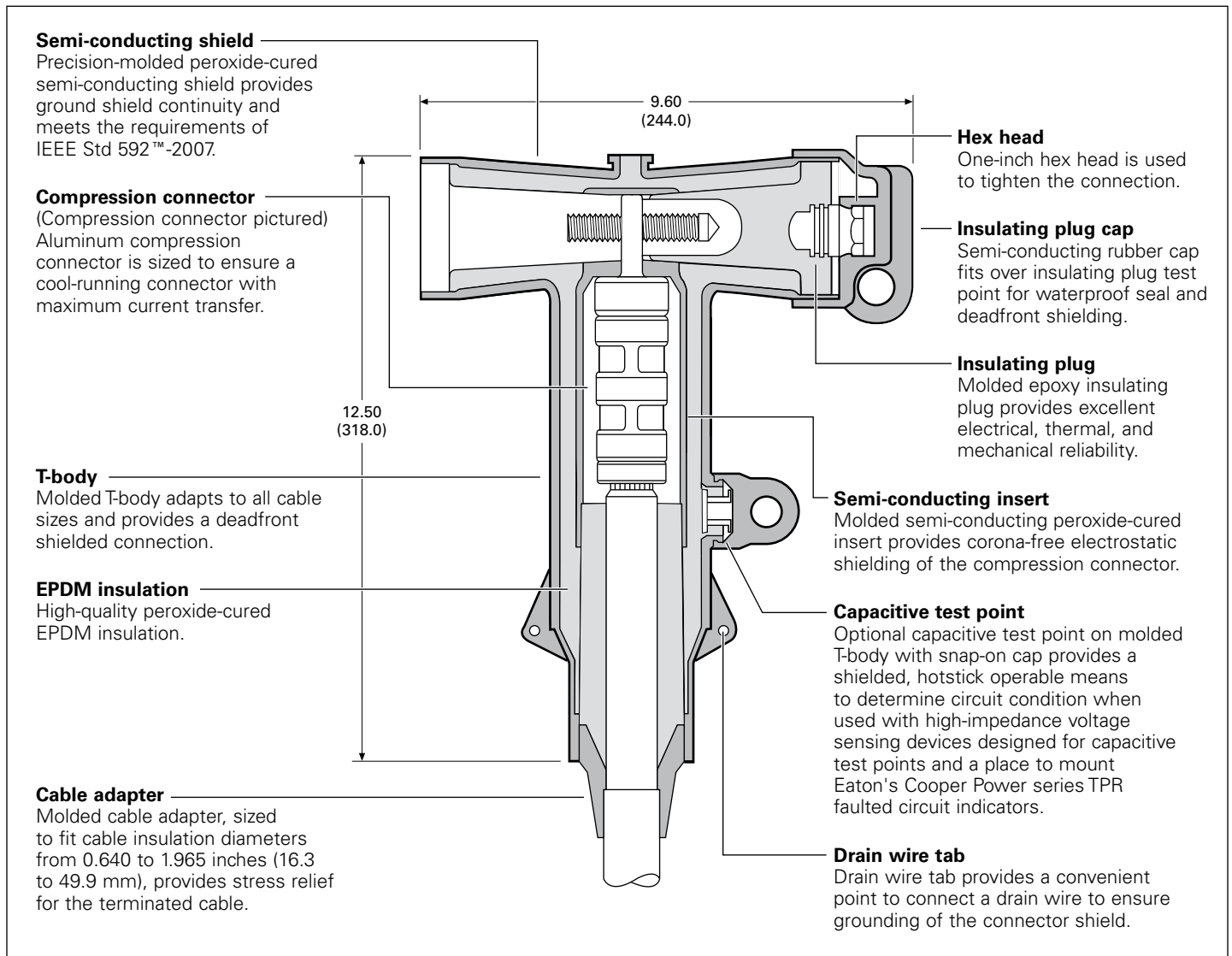

Figure 1. BOL-T cutaway design features

Note: Dimensions are in inches (mm) and are for reference only.

Optional features

Coppertop compression connectors

Coppertop compression connectors (aluminum sleeve welded to a copper spade) provide a high-conductivity material in a bolted connection and are compatible with aluminum or copper conductors.

Shear bolt connectors

Bolted cable lug is fitted with stepless bolts, which shear off when optimum contact force has been reached. Provide electrical continuity for copper and aluminum conductors while eliminating need for dies and compression tools.



Shear bolt connector

All copper current path

A full copper current-carrying path can be obtained by specifying a coppertop compression connector, copper stud, and copper insulating plug.

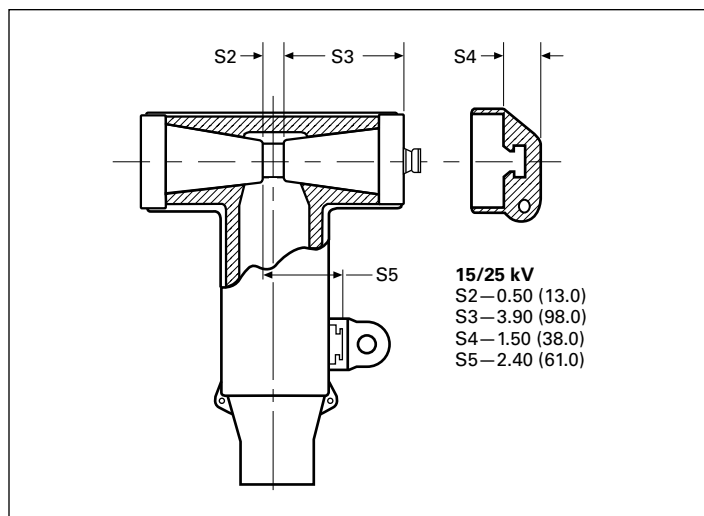

Figure 2. BOL-T stacking dimensions in inches (mm)

Ordering information

Each BOL-T connector kit contains:

- Molded rubber T-body
- Insulating plug
- Insulating plug cap
- Compression or shear bolt connector
- Cable adapter
- Silicone lubricant
- Installation instruction sheet

To order a 15/25 kV Class BOL-T connector kit, see following Steps 1–5 to build the catalog number.

BOL-T connector kit—catalog numbering system

Build the 12-digit catalog number for a BOL-T kit by following the steps given below. The first 5 digits are “BT625”; so only digits 6 through 12 need to be selected.

1	2	3	4	5	6	7	8	9	10	11	12
B	T	6	2	5							

Catalog number digits:

1 and 2 — “BT” = BOL-T connector system

3 — “6” = 600 A system

4 and 5 — “25” = 25 kV class bushing interface

Step 1. Select digits 6 and 7 cable adapter range code

Determine the cable’s diameter over the electrical insulation as shown in **Figure 3** (including tolerances).

Then identify a cable range from **Table 3** that covers the minimum and maximum insulation diameters.

Select the correct cable adapter range code from **Table 3**.

Table 3. Cable diameter range

Inches	mm	Cable adapter range code
0.61–0.97	15.5–24.6	AB
0.75–1.08	19.1–27.4	CC
0.97–1.31	24.6–33.3	DD
1.09–1.47	27.7–37.3	EE
1.26–1.64	32.0–41.7	FF
1.36–1.71	34.5–43.4	GG
1.51–1.85	38.4–47.0	HH
1.70–1.97	43.2–50.0	JJ

Step 2. Select digits 8 and 9 conductor code

Identify the conductor size and type in **Table 4** (compression) or **Table 5** (shear bolt) and select the conductor code from the appropriate column.

Table 4. Compression connector

Concentric or compressed		Compact or solid		Conductor code
AWG or kcmil	mm ²	AWG or kcmil	mm ²	
No connector				00
#2	35	1	—	11
#1	—	1/0	50	12
1/0	50	2/0	70	13
2/0	70	3/0	—	14
3/0	—	4/0	95	15
4/0	95	250	120	16
250	120	300	—	17
300	—	350	—	18
350	—	400	185	19
400	185	450	—	20
450	—	500	240	21
500	240	600	300	22
600	300	700	—	23
650	—	750	—	24
750	—	900	—	25
900	—	1000	500	26
1000	500	—	—	27
1250	630	1250	—	28

Table 5. Shear bolt connector

Cable conductor size				Conductor code	Catalog number
AWG or kcmil			mm ² standard sizes		
Compact	Compressed	Concentric			
1/0	1/0	1/0	50	S1	CDT630SB150
2/0	2/0	2/0	70		
3/0	3/0	3/0	—		
4/0	4/0	4/0	95		
250	250	250	120	S3	CDT630SB300
350	—	—	150		
—	350	350	185		
500	500	500	240		
600	600	600	300	S4	CDT630SB400
700	—	—	—		
—	700	700	—		
750	750	750	—		
800	800	—	400	S5	CDT900SB500
900	—	—	—		
—	—	800	—		
—	900	900	—		
1000	1000	1000	500		

Step 3. Select digit 10

Determine whether aluminum or copper is required for the compression connector, stud, and deadbreak insulating plug.

“**A**” = Aluminum (shear bolt or compression connector)

“**C**” = Copper mating components (shear bolt or copper top compression connector) (required to achieve 900 A rating)

Step 4. Select digit 11

Determine if a stud should be included in the kit.

“**1**” = Stud included

“**2**” = Stud not included

Step 5. Select digit 12 (optional)

Determine if the T-body should have a test point.

“**T**” = Test point on T-body

If no test point is required, do not include a 12th digit.

Example

Select a BOL-T kit for 250 kcmil compressed cable with a nominal insulation diameter of 1.160 ± 0.030 inches. The kit should have aluminum current-carrying parts and should have a stud included. The T-body should have a test point.

Step 1. Select digits 6 and 7

Nominal diameter over insulation is 1.160 ± 0.030 inches.

Minimum diameter = 1.160 – 0.030 = 1.130 inches.

Maximum diameter = 1.160 + 0.030 = 1.190 inches.

From **Table 3**, identify the cable range that covers 1.130–1.190 inches and select the “**EE**” cable range code.

Step 2. Select digits 8 and 9

The conductor size is 250 kcmil compressed. From **Table 4**, under the column “Concentric or compressed,” identify 250 kcmil and select the “**17**” conductor code.

Step 3. Select digit 10

The kit should have aluminum current-carrying parts. Select an “**A**” for digit 10.

Step 4. Select digit 11

The kit should include a stud. Select “**1**” for digit 11.

Step 5. Select digit 12

A test point is needed. Use “**T**” for digit 12.

The complete catalog number is: **BT625EE17A1T**.

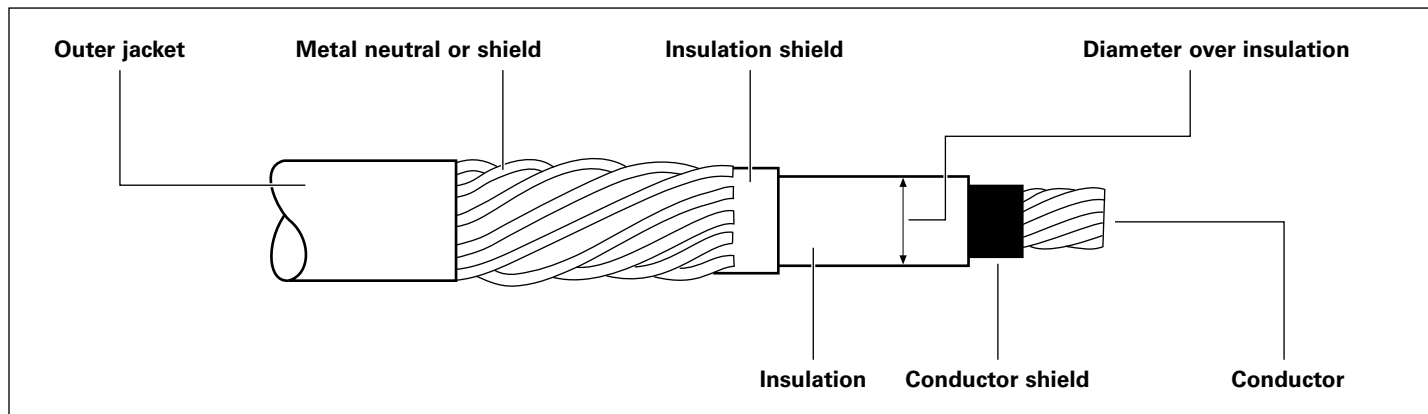

Figure 3. Typical construction of medium-voltage underground cable

Accessories

Cable adapters, compression connectors, and other accessories that can be used with BOL-T connectors are described in *Catalog Data CA650007EN, "Deadbreak accessories, tools, and replacement parts."*

Table 6. Replacement parts

Description	Catalog number
T-body without test point	DT625
T-body with test point	DT625T
T-body without test point with aluminum stud	DT625SA
T-body without test point with copper stud	DT625SC
T-body with test point with aluminum stud	DT625TSA
T-body with test point with copper stud	DT625TSC
Insulating plug cap	DIPCAP
Aluminum insulating plug with cap (no stud)	DIP625A
Copper insulating plug with cap (no stud)	DIP625C
Aluminum insulating plug with cap and aluminum stud	DIP625AS
Copper insulating plug with cap and copper stud	DIP625CS
5/8-inch—11 UNC 2 A aluminum threaded stud	STUD-A
5/8-inch—11 UNC 2 A copper threaded stud	STUD-C

Eaton
1000 Eaton Boulevard
Cleveland, OH 44122
United States
Eaton.com

Eaton's Power Systems Division
2300 Badger Drive
Waukesha, WI 53188
United States
Eaton.com/cooperpowerseries

© 2023 Eaton
All Rights Reserved
Printed in USA
Publication No. CA650003EN / Z27614
June 2023