DESCRIPTIVE BULLETIN

VersaRupter® medium voltage indoor switch

4.76-38 kV, 200-1200 A, 25-61 kA

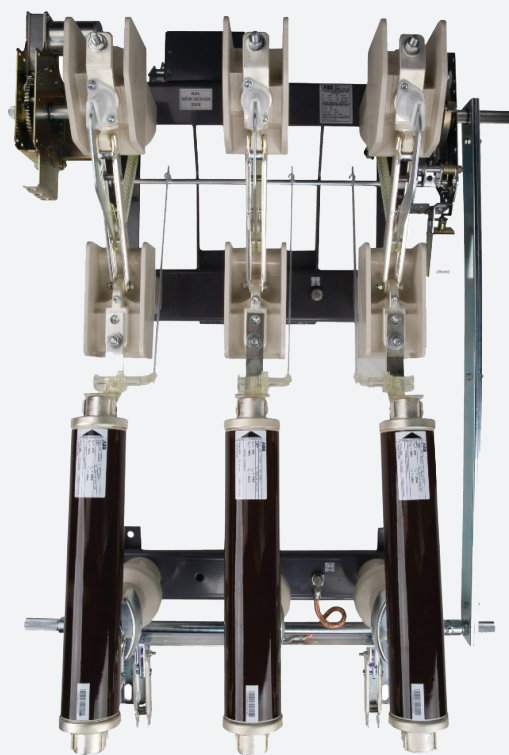

Table of contents

004	VersaRupter® switch overview
005	Technical data
006–007	Weights and dimensions
008	Operating mechanism
009	Operating handles
010	Optional accessories
011	Applications

VersaRupter® switch overview

General description

—
VersaRupter switch
assembled with snap
action K-mechanism

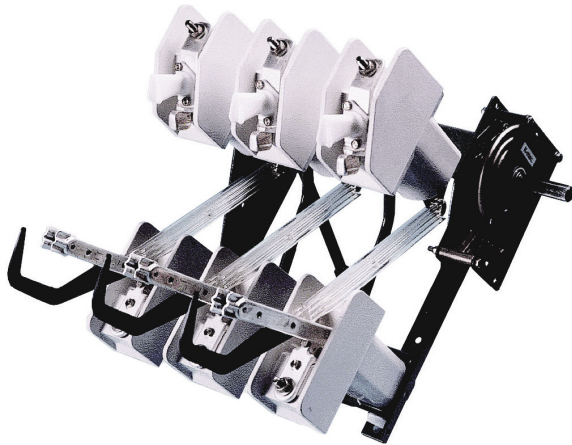

The VersaRupter switch is a general purpose, three-pole, loadbreak switch that offers switchgear owners and assemblers the advantages of an advanced interrupting technology and proven, dependable performance in a compact design. The switch is available to switchgear assemblers as a building block for metal-enclosed and padmounted switchgear applications in ratings from 4.76 – 38 kV.

- Puffer arc extinguishing system allows for a high number of operations without excessive wear
- Lack of gravity dependent latches allows for flexible mounting arrangements
- Tight phase spacing without the requirement for interphase barriers on most ratings
- Compact operating mechanisms available in stored energy or snap action varieties
- Compact motor operator provides local or remote control of the VersaRupter switch.

The VersaRupter switch includes a heavy-duty steel frame with stand-off insulators, a unique puffer type arc extinguishing system, and an operating mechanism. The current-carrying components include blade-type interrupters with cast hinges and jaw connectors. Optional accessories and features include operating handles, auxiliary switches, grounding switches, fuse bases, mechanical fuse tripping, motor operator, shunt trip, mechanical door interlocking, and key interlocking.

VersaRupter switch at a glance

Applications	Metal-enclosed and padmount switchgear for utility distribution, industrial, mining, and commercial installations		
Ratings	Voltage	Loadbreak current	Momentary
	4.76- 15 kV	200, 600, and 1200 A	40 kA momentary / 40 kA fault close
	27 kV	200, 600, and 1200 A	32 kA momentary / 32 kA fault close
	38 kV	600 and 800 A	25 kA momentary / 25 kA fault close
Standards	15-15.5 kV 600 and 1200 A 61 kA momentary / 61 kA fault close		
Standards	IEEE C37.20.4 (2001 and 2013) IEC 60129, 60254, 60265, 60694, 420, 62271-105 For UL and CSA listings see Tables 1A and 1B		
Experience	Over 35 years of product design and field experience with attention to product modernization and development		
Actuators	Manual operation with choice of chain drive, side direct drive, or HE/HM shaft drive Optional motor operation, optional shunt trip with A-mech only Left or right side mounting available with most options		
Options	Grounding switch, fuse base, mechanical fuse tripping, auxiliary switches, key interlocks		
Quality	ISO-9001 Complete IEEE design test reports Switches are tested to a minimum of 1,000 mechanical operations, 100 open/close operations up to 600 A, and 20 open/close operations at 1200 A		

Technical data

VersaRupter® switch technical details

Rated voltage (kV)	Rated maximum voltage (kV)	Rated current (A)	BIL (kV)	60 Hz withstand 1 minute (kV)	Pole spacing (in/mm)	Momentary asymmetrical (kA)	Fault-making asymmetrical (kA)	Peak withstand* (peak kA)	Fault-making* (peak kA)	Short time current symmetrical (kA/sec)
4.73	4.76	200	60	19	5.91/150	40	40	65	65	25/2
		600								
		1200								
12-13.8	15	200	95	36	6.69/170	40	40	65	65	25/2
		600								
		1200								
13.8	15	200	95	36	9.25/235	61	61	N/A	N/A	40/3
14.4	15.5	600	110	50	9.25/235	61	61	N/A	N/A	40/3
		1200								
		1200								
12-16.5	17	200	110	50	9.25/235	40	40	65	65	25/2
		600								
		1200								
23.9-24.9	27	200	125	60	10.8/275	32	32	65	52	25/2
		600								
		1200								
34.5	38	800	150	80	14.1/360	25	25	65	42	25/2
UL listed										
4.73	4.76	200	60	19	5.9/150	40	40	65	65	25/2
		600								
		1200								
13.8	15	200	95	36	6.69/170	40	40	65	65	25/2
		600								
		1200								
13.8	15	200	95	36	9.25/235	61	61	N/A	N/A	40/3
14.4	15.5	600	110	36	9.25/235	61	61	N/A	N/A	40/3
		1200								
		1200								
12-16.5	17	200	110	50	9.25/235	40	40	65	65	25/2
		600								
		1200								

*Per IEEE C37.20.4 (2013), momentary asymmetrical values are now peak withstand values, and fault-making asymmetrical values are now fault-making values. Variants with N/A are not retested to peak values.

Maximum torque at closing (ft-lbs)	85 - 89
Maximum torque at opening K-mech (ft-lbs)	89
Maximum torque at opening A-Mech (ft-lbs)	2.2
Operating rotation of shaft (degrees)	130
Arc time (ms)	10 - 20
Opening time (ms)	40 - 60

Weights and dimensions

Drawings

— Standard VersaRupter® switch - single hole lug.
Reference drawings for dimensions table on page 7.

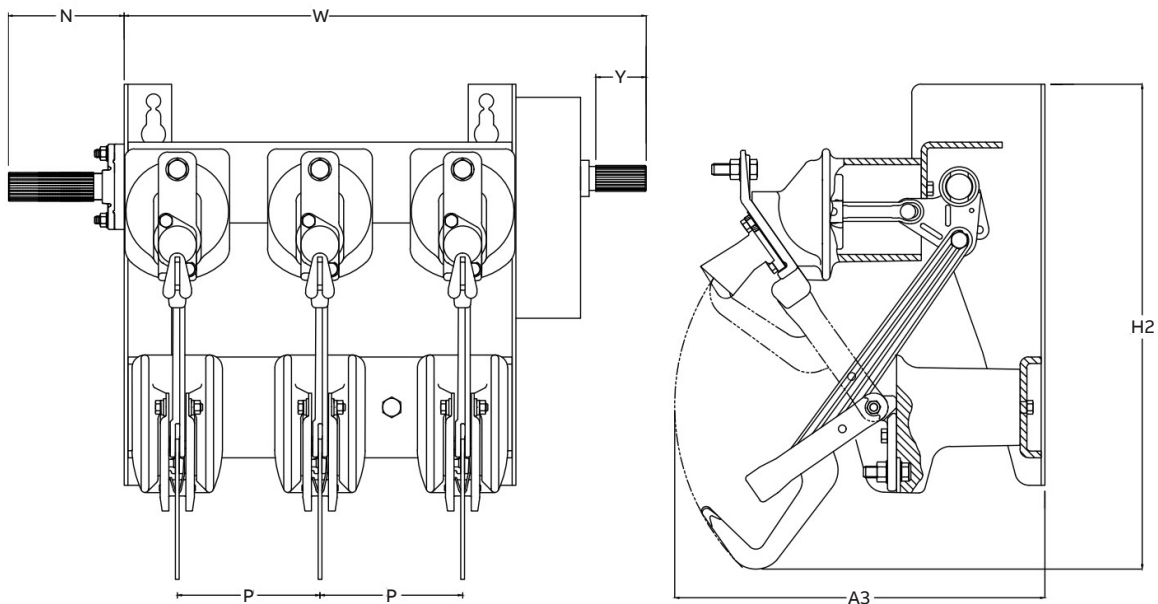

— NEMA 2-hole lug

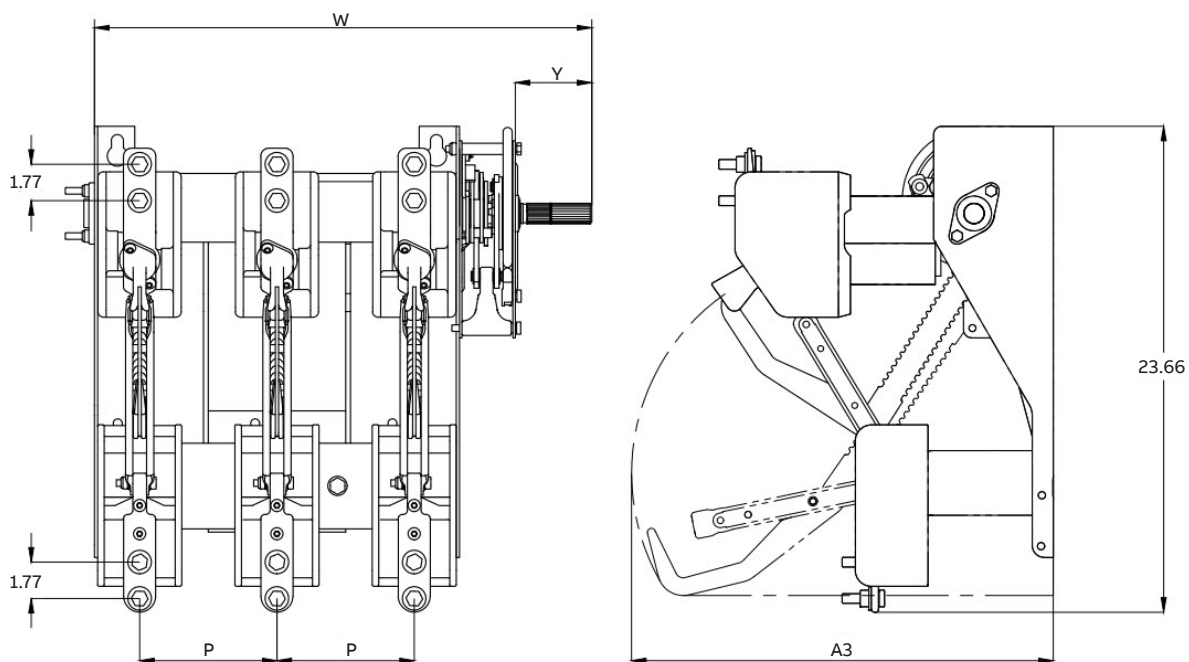

Weights and dimensions table

Dimensions (in)													
Switch max kV / phase spacing		Width ¹ (W)	Height (H2)	Depth (A3)	Optional shaft ext. (N)	Weight (lbs.)	Ref. drawing						
4.76 kV P = 5.91" (150 mm)	200 A	K-mechanism	22.68	20.08	15.51	4.80	71						
		A-mechanism	22.41										
	600 A	K-mechanism	22.68					S-20183					
		A-mechanism	22.41										
	15 kV P = 6.69" (170 mm)	200 A	K-mechanism						24.25	23.62	20.12	4.80	75
			A-mechanism						23.98				
600 A		K-mechanism	24.25	S-20184									
		A-mechanism	23.98										
15 kV (61 kA) 15.5 kV (61 kA) P = 9.25" (235 mm)		200 A	K-mechanism		24.25	24.17	21.55	7.32	110				
			A-mechanism		23.98								
	600 A	K-mechanism	29.37		S-20346								
		A-mechanism	29.10										
	17 kV P = 9.25" (235 mm)	200 A	K-mechanism	29.37						23.62	20.12	7.32	93
			A-mechanism	29.10									
600 A		K-mechanism	29.37	S-20348									
		A-mechanism	29.10										
27 kV P = 10.8" (275 mm)		200 A	K-mechanism		32.52	23.62	20.12	7.32	95				
			A-mechanism		32.25								
	600 A	K-mechanism	32.52		S-20347								
		A-mechanism	32.25										
	38 kV P = 14.1" (360 mm)	200 A	K-mechanism	32.52						34.25	33.46	10.08	220
			A-mechanism	32.25									
600 A		K-mechanism	46.61	NHP 241285									
		A-mechanism	46.12										
800 A		K-mechanism	46.61										
		A-mechanism	46.12										

¹Width for K-mechanism based on standard shaft (K3) where Y dimension = 3.77" excluding 38 kV where Y = 7.39"
Other options are: K2 snap action mechanism where Y = 2.69"
K5 snap action mechanism where Y = 5.26"

¹Width for A-mechanism based on standard shaft (A3) where Y dimension = 3.50" excluding 38 kV where Y = 6.90"
Other options are: A4 stored energy mechanism where Y = 4.80"
A6 stored energy mechanism where Y = 6.90"

Note: See definitions for K and A mechanisms on page 8.

Operating mechanism

Selection guide

—
01
Snap action
K-mechanism

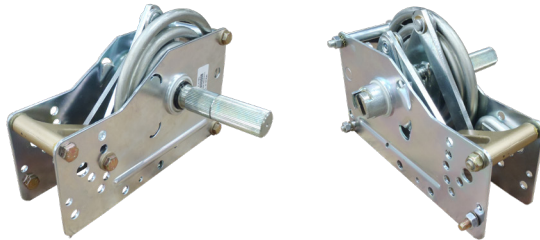

—
01

—
02
Stored energy
A-mechanism

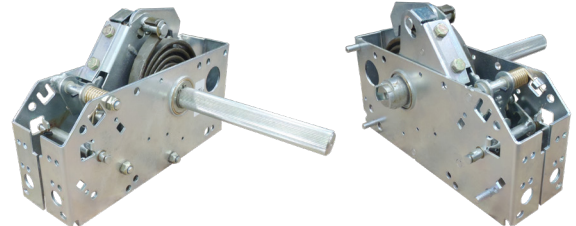

—
02

Snap action K-mechanism

The K-mechanism is a single spring snap action device. The switch opens or closes by charging the spring past dead center using one of the manual operating handles. The K-mechanism may be used with all handle options as well as with type NM motor operators. The K-mechanism cannot be used for shunt trip or fuse trip applications.

- Use the K-mechanism if you need chain drive or side direct drive handles.

Stored energy A-mechanism

The A-mechanism is a dual spring stored energy device that is well suited for remote tripping applications. When shunt tripping or mechanical fuse tripping is specified, the type A-mechanism must be used. In closed operation, the opening spring is charged and latched by an operating handle or by a motor operator. The VersaRupter® switch is then opened by any of the following methods below:

- Movement of the operating handle
- Motor operator
- Electrical signal to a shunt trip device
- Mechanical fuse tripping linkage

Operating features and functions

		Mechanism type			
		Snap action K-mech		Stored energy A-mech	
		40/32/25 kA	61 kA	40/32/25 kA	61 kA
UL recognized and CSA compliant		X	X	X	X
Remote shunt trip ¹				X	X
Auxiliary switch		X	X	X	X
Electrical control options				X	
Open fuse auxiliary switch				X	
Side direct drive		X	X		
HE shaft drive ²		X	X	X	X
HM shaft drive		X	X	X	X
Operating handles					
Chain drive		X	X		
Motor operator (optional)					
NM motor ³		X	X	X	X
Mechanical door interlock		X	X	X	X
Key interlock		X	X	X	X
Interlocks					
Padlock		X	X	X	X
Type E grounding switch		X		X	
Grounding switch					
Mechanical interlock		X		X	
Fuse bases		X		X	
Fuse options					
Mechanical fuse tripping ⁴				X	

¹ Shunt trip option provides for operation by local push button or remote signal. Shunt trip requires stored energy type A-mechanism.

² The HM drive must be used if manual operation is needed in conjunction with motor operator.

³ Chain and direct drive handles cannot be used with motor operators.

⁴ This feature provides for the switch to open if a fuse operates.

Operating handles

Selection guide

The VersaRupter® switch can be operated with a variety of handles as well as a motor operator. Operators may be mounted in a variety of positions and offer various features. Some operators are not compatible with all mechanisms and features. The chart below provides compatibility guidance.

Selection guide - operators vs. feature compatibility

Handle operator	Location	Use with K-mech	Use with A-mech	Mechanical door interlock	Key interlock	Shunt trip	Motor operator ¹
Chain drive without door interlock	Front mounted with left or right side drive	•			•		
Chain drive with door interlock	Front mounted with left or right side drive	•		•	•		
Direct drive	Shaft mounted with left or right side drive	•			•		
Manual shaft drive type HE ² without door interlock	Front mounted with right or left side drive	•	•		•	•	
	Manual with NM motor (HM handle)	•	•		•	•	•
Manual shaft drive type HE ² with door interlock	Front mounted with right or left side drive	•	•	•	•	•	
	Manual with NM motor (HM handle)	•	•	•	•	•	•

Handle options with type K snap action mechanism

Front mounted chain drive handle without mechanical door interlock	Right side mounting
	Left side mounting
Front mounted chain drive handle with mechanical door interlock	Right side mounting
	Left side mounting
(side mounted) Direct drive handle	Right side mounting
	Left side mounting
(front mounted) HE/HM shaft operator	Right side mounting
	Left side mounting



Direct drive handle



Chain drive Kirk Key right

Handle options with Type A stored energy mechanism

(front mounted) HE shaft operator	Right side mounting
	Left side mounting
(front mounted) HM shaft operator (use with NM motor)	Right side mounting
	Left side mounting

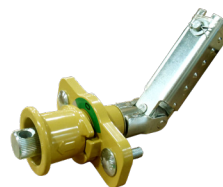

HE



HM

Optional accessories

Electrical control options

The shunt trip option is available for local push button or remote switching applications. The shunt trip can only be installed on a VersaRupter® switch with a stored energy mechanism (A-mechanism). The shunt trip utilizes a solenoid to actuate the A-mechanism trip latch.

The auxiliary switch can be installed on all VersaRupter switches. The auxiliary switch contacts change state when the VersaRupter switch contacts change state.

The compact, lightweight NM motor operator provides for remote electrical opening and closing of the VersaRupter switch. The NM motor operator is installed on the splined shaft of the VersaRupter switch mechanism (either K-mechanism or A-mechanism) or on a left-hand shaft extension.

Optional accessories

The VersaRupter switch can be equipped with a fuse base and/or a grounding switch. Grounding switches are available for connection to the lower terminals of the VersaRupter switch or the VersaRupter switch fuse base. Fuse bases are offered for mounting Type CEF fuses, with or without fuse tripping, on the upper or lower terminals of the VersaRupter switch rated below 1200 A. An optional fuse auxiliary switch is available to indicate an open fuse condition if equipped with fuse tripping.

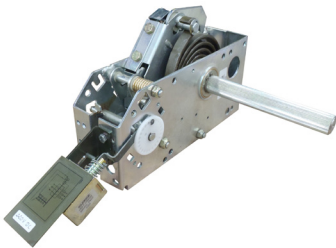

01

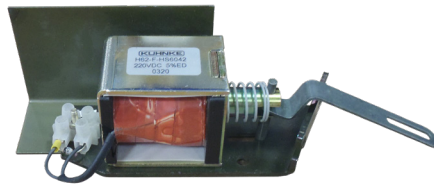

02

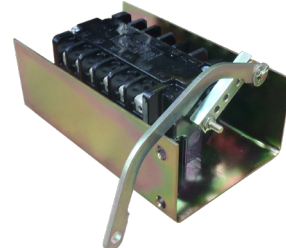

03



04

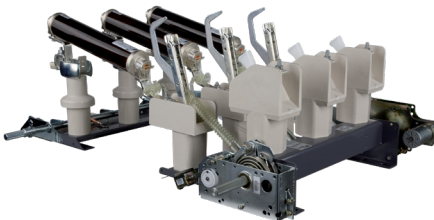

05



06

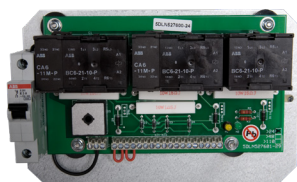

07

01 Shunt trip installed

02 Shunt trip

03 Aux switch

04 Type E grounding switch

05 VersaRupter switch with fuse base, ground switch, motor operator, and shunt trip installed

06 NM motor operator

07 Motor controller

Applications



The main purpose of the VersaRupter® load break switch is to interrupt loads and open circuits under normal current. The VersaRupter switch has been used in the following applications:

- In transformer and motor protection with the use of fuses
- As a visual disconnect in mining applications
- In pad-mounted switch applications
- In various metal enclosed switchgear configurations such as switch over breaker, duplex, and maintenance bus scenarios



Additional information

We reserve the right to make technical changes or modify the contents of this document without prior notice. With regard to purchase orders, the agreed particulars shall prevail. ABB Inc. does not accept any responsibility whatsoever for potential errors or possible lack of information in this document.

We reserve all rights in this document and in the subject matter and illustrations contained therein. Any reproduction, disclosure to third parties or utilization of its contents – in whole or in parts – is forbidden without prior written consent of ABB Inc.



—

ABB Inc.

3022 NC 43 North
Pinetops, NC 27864
Phone: +1 252 827 3212

Customer service:

+1 800 929 7947 ext. 5
+1 407 732 2000 ext. 2510

Email: customer.service.group@us.abb.com

www.abb.com/mediumvoltage