

38 kV Bay-O-Net fuse link



General

Eaton protects distribution apparatus from damaging currents and distribution systems from failed apparatus with its Cooper Power™ series 38 kV Bay-O-Net fuse link when used in Eaton's Cooper Power series 38 kV silver-plated Bay-O-Net assemblies. (See *Catalog CA132015EN 23 kV and 38 kV Sidewall-Mounted and 23 kV Cover-Mounted Bay-O-Net Fuse Assembly* for information about the fuse assembly).

Application

38 kV Bay-O-Net fuses were designed to allow the fusing of solar, wind and other 24 – 38 kV rated pad-mounted transformer applications.

Its ideal use is in a two-fuse protection scheme with a current-limiting backup fuse. In this arrangement, secondary faults and overload currents are cleared by the Bay-O-Net fuse, and high level faults are cleared by the current-limiting fuse. The two fuses are connected in series and are coordinated so that the current-limiting fuse operates only upon internal transformer failure (see *Catalog CA132013EN ELSP Current-Limiting Backup Fuse* to order an Eaton ELSP current-limiting back-up fuse).

The 38 kV Bay-O-Net fuse is an integrated fuse link and cartridge design specially engineered to simplify re-fusing and prevent mis-installation. The Bay-O-Net fuse design allows the integral (link) cartridge to be easily field replaceable in a 38 kV Bay-O-Net assembly.

38 kV links should only be used in Eaton's Cooper Power series 38 kV silver-plated Flapper™ valve Bay-O-Net fuse assemblies in order to ensure the intended operating characteristics.

All 38 kV fuse links must only be used in series with a 38 kV rated ELSP current-limiting backup fuse or equivalent. 38 kV fuse links cannot be used with an isolation link.

Installation

No special tools are required. A hotstick is used to remove the Bay-O-Net fuse cartridge holder from non-pressurized apparatus. The entire fuse cartridge is then replaced. No field installation of the fuse link into the cartridge is required. The fuse holder is then reinstalled into the apparatus using a hotstick. Refer to *Service Information MN132002EN Bay-O-Net Fuse Re-Fusing Installation Instructions* for refusing instruction.

EAT•N

Powering Business Worldwide

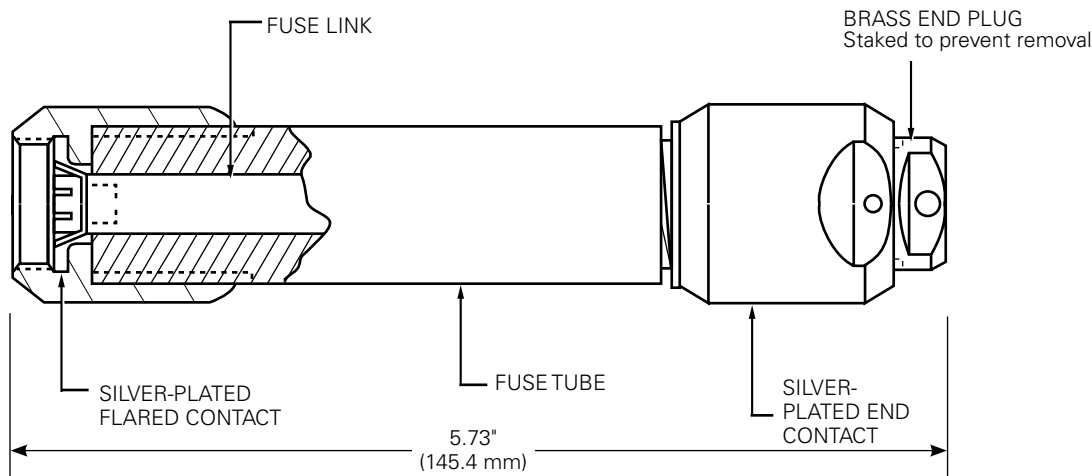

Figure 1. Cutaway drawing of 38 kV Bay-O-Net fuse link with feature information, (with reference dimension).

Table 1. Electrical Ratings and Characteristics

Voltage (kV)	Maximum Single-Phase Interrupting Rating*	
	Sidewall Mount Assembly (rms symmetrical) in Mineral Oil	Sidewall Mount Assembly (rms symmetrical) in Envirotemp™ FR3™ Fluid
38.0	900 A for 10 - 40 A 1000 A for 65 A	900 A for 10 - 40 A 1000 A for 65 A

* In Eaton's Cooper Power series Bay-O-Net assemblies only. Where available fault current exceeds rated value, coordinated current-limiting fusing, such as an ELSP (Catalog CA132013EN) or approved equivalent, must be provided.

Ordering information

To order a 38 kV Bay-O-Net fuse link, determine the requirements of the application from Tables 3 and 4 and specify the fuse required from Table 2.

Table 2. 38 kV Bay-O-Net Fuse Link

Current Rating (A)	Catalog Number*
10	4000380C06CB
15	4000380C08CB
25	4000380C10CB
30	4000380C11CB
40	4000380C12CB
65	4000380C14CB

* Catalog number is an integral element/cartridge/end plug design.

Method A

Using the Correlation Tables

Use the following correlation information (Table 3) to complete Catalog Number 4000380C--CB.

Eaton recommends its Cooper Power series ELSP current-limiting backup fuse for three-phase applications. (See *Catalog CA132013EN ELSP Current-Limiting Backup Fuse* for more information.)

Correlation is based on IEEE Std C57.92™-1981 standard Loading Guide, IEEE Std C57.109™-1993 standard Through-Fault Guide and *Reference Data TD132004EN Pad-Mounted Transformer Fusing Philosophies*.

Method B

Using Time Current Curves

To determine or confirm the 38 kV Bay-O-Net fuse that will coordinate with upstream and downstream requirements, use time-current characteristic curves and specify the fuse indicated from Table 2.

For full size TCC curve TC132001EN contact your Eaton representative.

**Table 3. Correlation Information
Three-Phase Transformer (Phase-to-Phase) Applications**

Transformer KVA Rating	Transformer Primary Voltage (kV) ^a			
	24.94	26.4	27.6	34.5
	BON Fuse	BON Fuse	BON Fuse	BON Fuse
150	C06CB	C06CB	C06CB	C06CB
225	C06CB	C06CB	C06CB	C06CB
300	C08CB	C08CB	C08CB	C06CB
500	C10CB	C10CB	C10CB	C08CB
750	C10CB	C10CB	C10CB	C10CB
1000	C12CB	C12CB	C11CB	C10CB
1100	C12CB	C12CB	C12CB	C11CB
1250	C12CB	C12CB	C12CB	C11CB
1500	C14CB	C12CB	C12CB	C12CB
1750	C14CB	C14CB	C14CB	C12CB
1850	C14CB	C14CB	C14CB	C12CB
2000	C14CB	C14CB	C14CB	C12CB
2250	C14CB	C14CB	C14CB	C14CB
2500	–	–	C14CB	C14CB
2850	–	–	–	C14CB
3000	–	–	–	C14CB
3100	–	–	–	C14CB
3200	–	–	–	C14CB

Note: Coordination recommendations are based on 12X transformer full load for 0.10s, 3X transformer full load for 10s.

a. Must be used with 38 kV rated ELSP fuse (CA132013EN)

Eaton

1000 Eaton Boulevard
Cleveland, OH 44122
United States
Eaton.com

Eaton's Cooper Power Systems Division

2300 Badger Drive
Waukesha, WI 53188
United States
Eaton.com/cooperpowerseries

© 2015 Eaton
All Rights Reserved
Printed in USA
Publication No. CA132006EN
March 2015

Eaton, Cooper Power, and Flapper are valuable trademarks of Eaton in the U.S. and other countries. You are not permitted to use these trademarks without the prior written consent of Eaton.

IEEE Std C57.92™-1981 and Std C57.109™-1993 standards are trademarks of the Institute of Electrical and Electronics Engineers, Inc., (IEEE). This publication is not endorsed or approved by the IEEE.
Envirotemp™ and FR3™ are licensed trademarks of Cargill, Incorporated.

For Eaton's Cooper Power series Bay-O-Net fuse link product information call 1-877-277-4636 or visit: www.eaton.com/cooperpowerseries.