

# Four-position sectionalizing loadbreak switches



## General

Eaton's Cooper Power™ series four-position sectionalizing loadbreak switch is designed for use in transformer (mineral) oil, Envirotemp™ FR™ fluid, or an approved equivalent fluid-filled pad-mounted transformers or distribution switchgear. The switches meet the full requirements of the latest revision of both IEEE® and IEC standards.

Sectionalizing switches can be used on single- and three-phase grounded wye or delta systems. They are used in underground residential applications with loop feed, and in three-phase commercial industrial installations where the ability to use an alternative source of power is necessary. They can also be used to switch on and off a primary cable tap on a transformer.

The under-oil switch can be installed near the transformer core/coil assembly, thus minimizing cable capacitance. With cable capacitance minimized and all three phases switched simultaneously, the likelihood of ferroresonance is greatly reduced. All switches are hotstick operable and available in several different blade configurations (Refer to Table 4).

Eaton's Cooper Power series sectionalizing switches rotate 360° in either direction for alternate source selection. An externally installed limiting plate prevents rotation to positions other than the one desired. A spring-loaded activating mechanism ensures quick loadbreak action and positive contact engagement through all positions.

The Make-Before-Break (MBB) switches provide uninterrupted power during switching.

**EATON**

*Powering Business Worldwide*

## Make-before-break features

- Improves system reliability by eliminating momentary interruptions during switching operations typically associated with Break-Before-Make (BBM) sectionalizing switches.
- Replaces 2 or 3 two position loadbreak switches depending on application (Choose V-blade or T-blade type).
- Simplifies operational procedures.
- Make-Before-Break design is only available for V- and T-blade switch types.

## Attributes

- Available for both 12 kA and 16 kA applications.
- Ratings from 200 A to 630 A and from 15 kV to 38 kV.
- Tested in mineral oil and Envirotemp™ FR3™ fluid.
- All electrical switching tests performed at third-party certified test laboratories
- 5000 mechanical operations (meets IEC class M2 switch).
- All silver plated copper current path.
- Similar "footprint" as previous 10 kA switches (See Tables 3 and 4).
- The Ring-Mount System option offers easy and fast installation.
- Special vertical mounted switches available for cover mounted applications.

## Production tests

Tests are conducted in accordance with Eaton requirements:

- Physical Inspection
- Mechanical operations
- Operating torque
- Contact pressure
- Switch contact resistance

## Installation

The switch is either horizontally or vertically mounted, depending on the application and the selected switch type. The vertically mounted switch is typically used in transformers/switchgear installed below grade, where the switch would be mounted in the cover of that particular equipment. All exposed parts of the vertically mounted switch are made from stainless steel or other non-corrosive materials. Both types of switches, including the mechanism, must be completely immersed under the insulating fluid.

**Note:** For all mounting systems, refer to *Service Information MN800002EN Sectionalizing Switch Installation Instructions* for more detailed installation instructions.

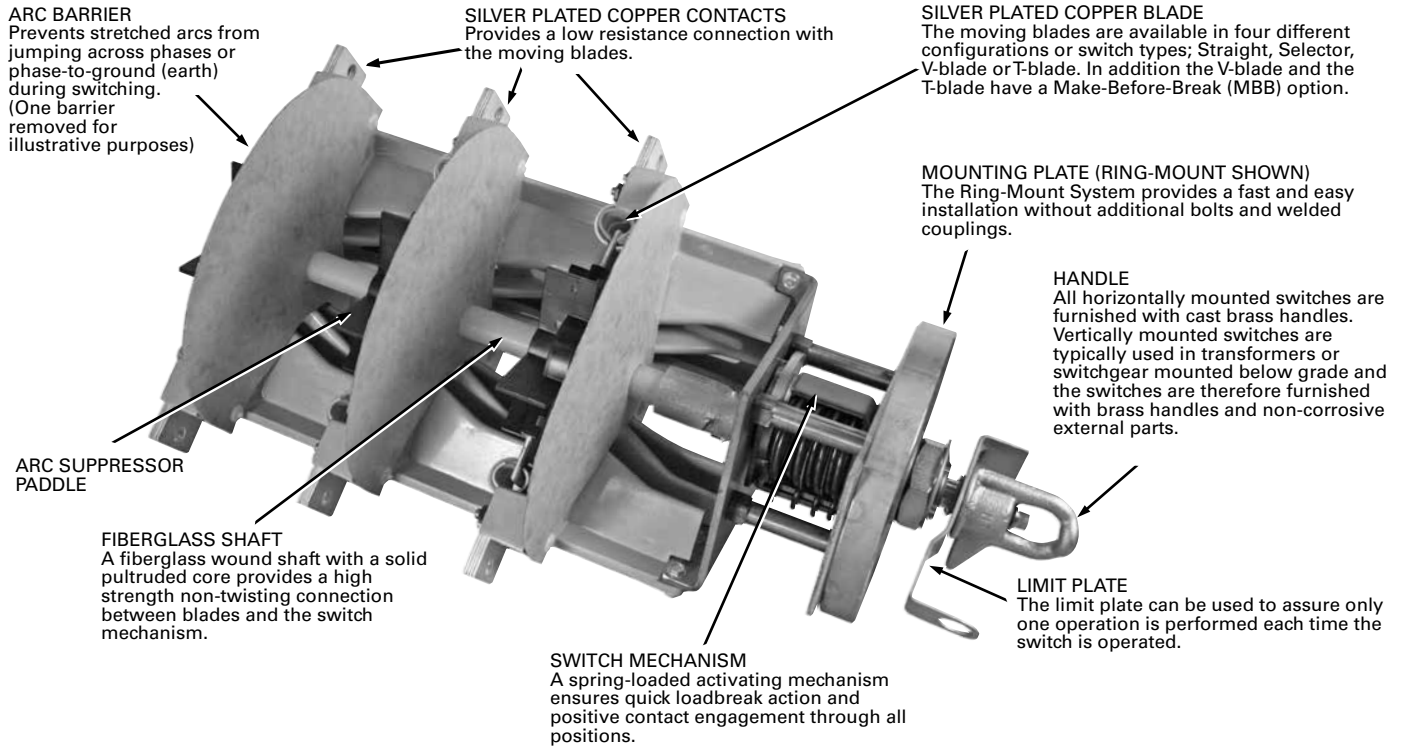

Figure 1. Switch features and description.

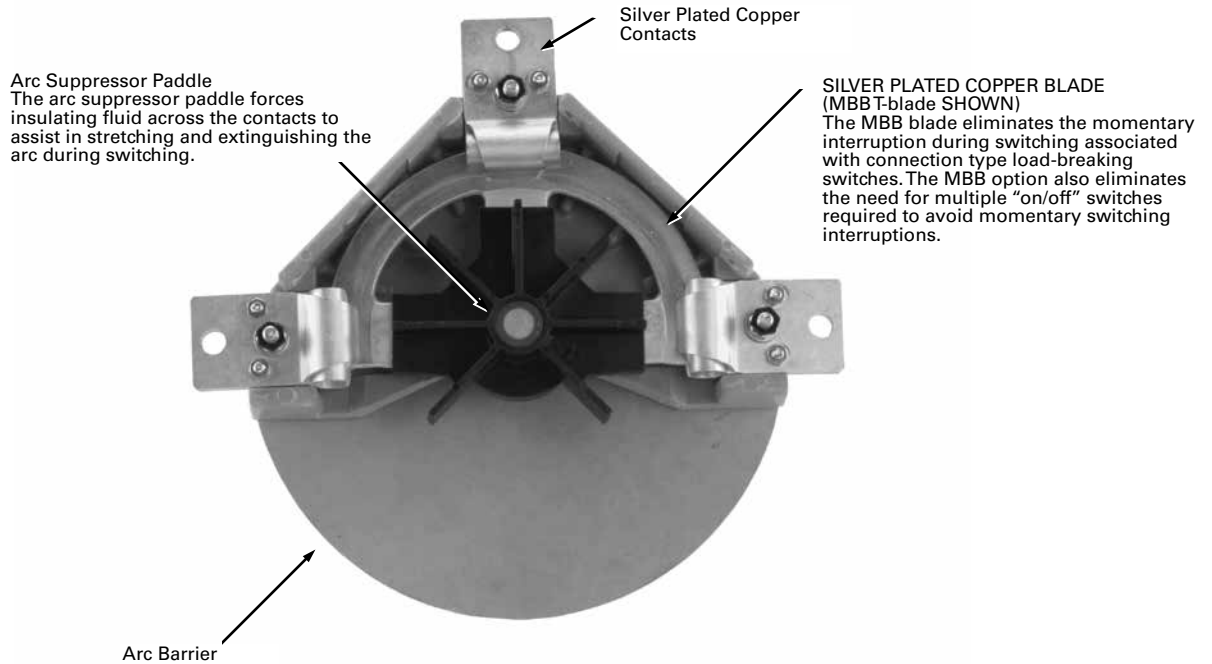

Figure 2. Make-Before-Break switch features and description (See Table 5 for application details).

**Electrical ratings**

**Table 1. Ratings and Characteristics per IEEE Std C37.71™-2001 Standard**

	Units	12.5 kA Rated Switches to IEEE Std C37.71™ - 2001 standard		
Rated Voltage				
Maximum rating phase-to-phase	kV	15.5	27.8	38
Maximum rating phase-to-ground	kV	9	17.2	21.9
Power Frequency	Hz	60	60	60
Current rating (Continuous)	A	630	300	200
Loadbreak Capability @ 0.75 Power Factor	A	630	300	200
First peak min/Time-to-peak max.	kV µs	4 180	7.6 290	13 424
Magnetizing	A	22	10.5	7
Cable Charging	A	10	25	40
Fault Withstand Current (Momentary)				
10 cycle symmetric rms	kA	12.5	12.5	12.5
10 cycle asymmetric rms	kA	18.6	18.6	18.6
10 cycle peak	kA	32.6	32.5	32.5
Fault Withstand (Short-time)				
1s rms	kA	12.5	12.5	12.5
2s rms	kA	12.5	12.5	12.5
Fault Close and Latch				
10 cycle symmetric rms	kA	12.5	12.5	12.5
10 cycle asymmetric rms	kA	18.6	18.6	18.6
10 cycle peak	kA	32.5	32.5	32.5
Impulse Withstand Voltage (1.2/50 µs)				
To ground and between phases	kV	95	125	150
Across open contacts	kV	95	125	150
Power Frequency (1 minute)				
To ground and between phases	kV	35	60	70
Across open contacts	kV	35	60	70
DC Withstand (15 minutes)				
To ground and between phases	kV	53	78	103
Across open contacts	kV	53	78	103
Corona (Extinction)	kV	26	26	26
Temperature Maximum at 630 A	°C	75	75	75
Temp. Rise Above Ambient Air at 630 A (Max.)	°K	35	35	35
Mechanical Life (Minimum Operations)		5,000	5,000	5,000

**Table 2. Ratings and Characteristics per IEC 60265-1 – 1998**

	Units	16 kA Rated Switches to IEC 60265-1 - 1998		
Switch Rating	kV	15	24	36
Rating voltage				
Maximum rating phase-to-phase	kV	15.5	24.9	38
Maximum rating phase-to-earth	kV	9	14.4	21.9
Power Frequency	Hz	50/60	50/60	50/60
No-Load Transformer Breaking Current	A	6.3	4	2
Current Rating (Continuous)	A	630	400	200
Mainly Active Load Breaking Current				
First peak min.	A	630	400	200
Time-to-peak max.	kV µs	25.7 72	41 88	65.1 108
Closed Loop Breaking Current	A	630	400	200
Line Charging Current	A	1	1.5	2
Cable Charging Current	A	10	17	25
Earth Fault Switching Current	A	1	10	8
Cable and Line Charging Under Earth Fault	A	17.5	17	26
Short-time Withstand Current				
1s rms	kA	20	20	20
2s rms	kA	16	16	16
3s rms	kA	13	13	13
Short-circuit Making Current				
12 cycle symmetric rms (min.)	kA	16	16	16
12 cycle asymmetric rms (min.)	kA	24.8	24.8	24.8
12 cycle max. peak (min.)	kA	41.6	41.6	41.6
Impulse Withstand Voltage (1.2/50 µs)				
To earth and between phases	kV	170	170	170
Across open contacts (isolating distance)	kV	195	195	195
Power Frequency (1 Minute)				
To earth and between phases	kV	70	70	70
Across open contacts (isolating distance)	kV	80	80	80
Corona (Extinction)	kV	26	26	26
Temperature Maximum at 630 A	°C	90	90	90
Temp. Rise Above Ambient Air at 630 A (Max.)	°K	50	50	50
Mechanical Life (Minimum Operations)		5,000	5,000	5,000

**Dimensional information**

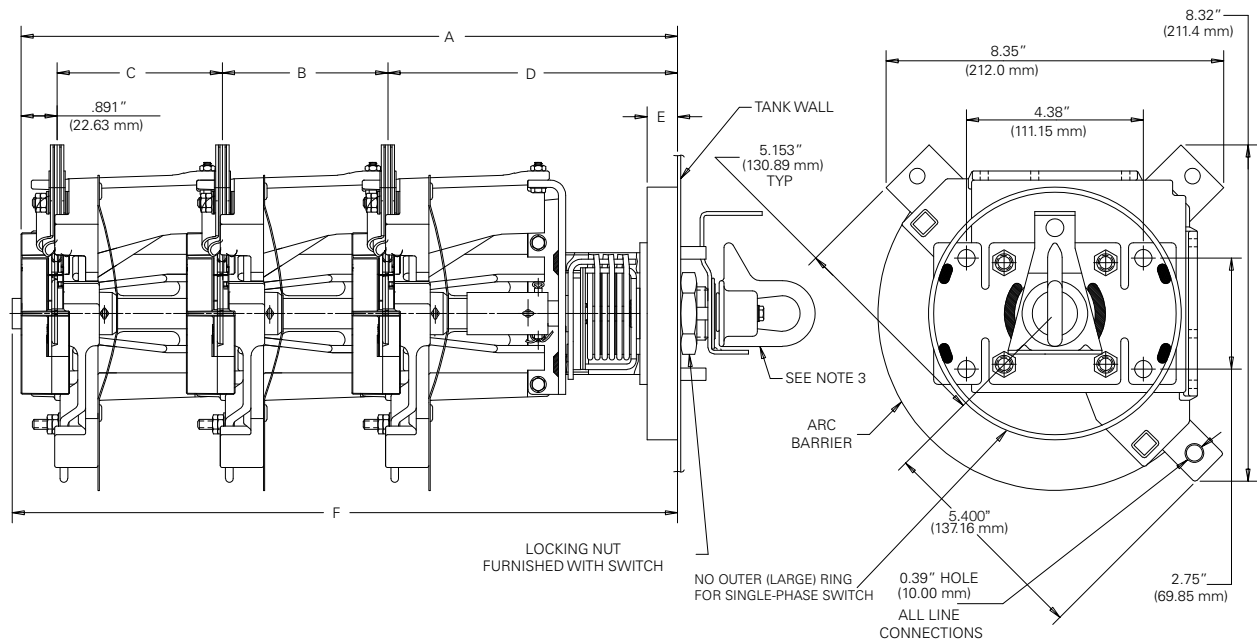

**Figure 3. Line illustration with dimensions of sectionalizing switch with "Ring-Mount System."**

**Notes:**

1. Dimensions given in Figure 3 and Table 3 are for reference only.
2. Handle can be used on 14 gauge .075 inch (1.9 mm) to .25 inch (6.4 mm) thick frontplate. 14 gauge shown.
3. Optional padlock handle is available. (See Table 6, Figure 6.)

**Table 3. Dimensional Information for Figures 3 and 4 (inches/mm)**

No. of Decks/Phases	kV Ratings & Blade Type	A		B	C	D		E		F	
		Horizontal Mount	Vertical Mount			Horizontal Mount	Vertical Mount	Horizontal Mount	Vertical Mount	Horizontal Mount	Vertical Mount
1	All	8.05" 204 mm	13.3" 338 mm	—	—	7.16" 182 mm	12.4" 315 mm	0.75" 19 mm	6.00" 152 mm	8.46" 215 mm	13.7" 348 mm
2	All	12.1" 307 mm	17.4" 442 mm	4.09" 104	—	7.16" 182 mm	12.4" 315 mm	0.75" 19 mm	6.00" 152 mm	12.5" 318 mm	17.7" 450 mm
3	12 kA T-Blade 12 & 16 kA Selector, Straight, & V-Blade	16.2" 411 mm	21.5" 546 mm	4.09" 104 mm	4.09" 104 mm	7.16" 182 mm	12.4" 315 mm	0.75" 19 mm	6.00" 152 mm	16.5" 419 mm	21.7" 551 mm
3	16 kA T-Blade Only	16.7" 424 mm	—	4.09" 104 mm	4.09" 104 mm	7.56" 192 mm	—	0.75" 19 mm	—	16.9" 429 mm	—

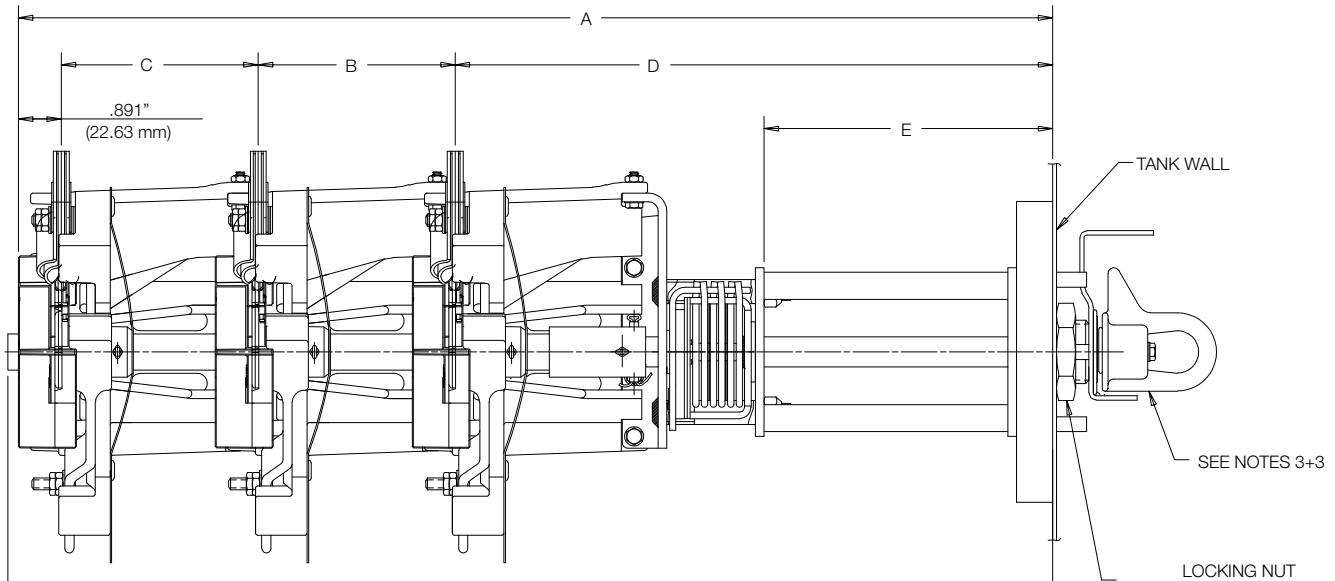

**Figure 4. Line illustration with dimensions of sectionalizing switch with vertical "Ring-Mount." (Side view only, refer to Figure 3 for Front View.)**

- Notes:**
1. Dimensions given in Figure 4 and Table 3 are for reference only.
  2. Handle can be used on 14 gauge .075 inch (1.9 mm) to .25 inch (6.4 mm) thick frontplate. 14 gauge shown.
  3. Optional padlock handle is available. (See Table 6, Figure 6.)

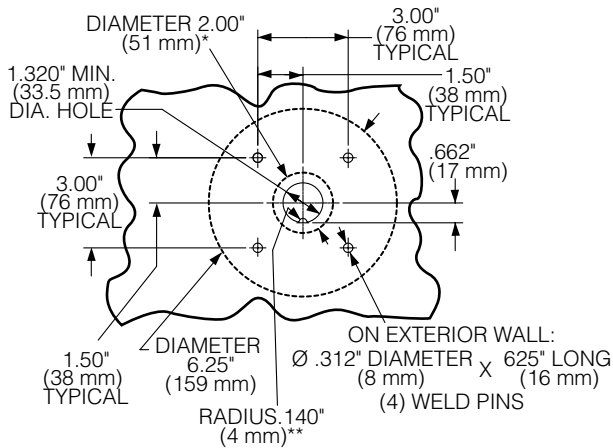

**Figure 5 Hole and weld pin placement (Ring-Mount system).**

- \* Exterior mounting surface must be flat within .010" (0.25 mm) over entire area.
- \*\* Interior mounting surface must be clear of obstructions.

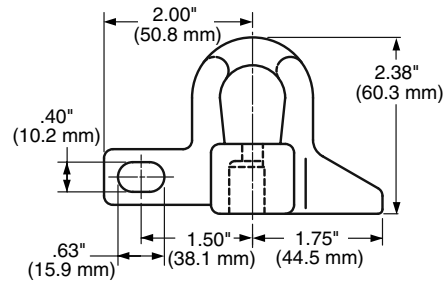

**Figure 6. Padlockable Handle.**

**Note:** For use with interlock systems. Will not function with optional limit plate and weld pins.

Table 4. Wiring Schematics

SWITCH TYPE	TYPICAL DECAL STENCIL LAYOUT	VIEW OF CONTACTS FROM FRONT (HANDLE) END OF SWITCH	POSITION 1 FRONT SCHEMATIC AS SHIPPED AND AS SHOWN AT LEFT	POSITION 2 SCHEMATIC SWITCH HANDLE ROTATED 90° CLOCKWISE FROM POSITION 1	POSITION 3 SCHEMATIC SWITCH HANDLE ROTATED 90° CLOCKWISE FROM POSITION 2	POSITION 4 SCHEMATIC SWITCH HANDLE ROTATED 90° CLOCKWISE FROM POSITION 3
STRAIGHT BLADE	CLOSE OPEN OPEN CLOSE					
SELECTOR BLADE ON-OFF	CLOSE OPEN OPEN OPEN					
SELECTOR BLADE 1 BLADE SIDE	LINE A TO C OPEN LINE B TO C OPEN					
SELECTOR BLADE 1 BLADE CENTER	LINE A TO C OPEN OPEN LINE B TO C					
V-BLADE BREAK BEFORE MAKE	LINES A & B TO C LINE A ONLY TO C LINE B ONLY TO C OPEN (ALL)					
V-BLADE MAKE BEFORE BREAK	LINES A & B TO C LINE A ONLY TO C LINE B ONLY TO C OPEN (ALL)					
T-BLADE BREAK BEFORE MAKE	LINES A & B TO C LINE A ONLY TO C LINE B ONLY TO C LINES A TO B C OPEN					
T-BLADE MAKE BEFORE BREAK	LINES A & B TO C LINE A ONLY TO C LINE B ONLY TO C LINES A TO B C OPEN					

NOTE:  
 1. SWITCH CENTER IS PIVOT POINT. BLACK SEGMENTS OF BLADE ROTATE.  
 WHITE OUTLINED SEGMENTS ARE STATIONARY.  
 2. OTHER POSITION SEQUENCES AVAILABLE – CONSULT FACTORY FOR DETAILS.

### Ordering information

To order a four-position sectionalizing loadbreak switch, specify the switch type desired from Table 4 and then build the catalog number from Table 5.

**Table 5. Catalog Number Selection Chart**

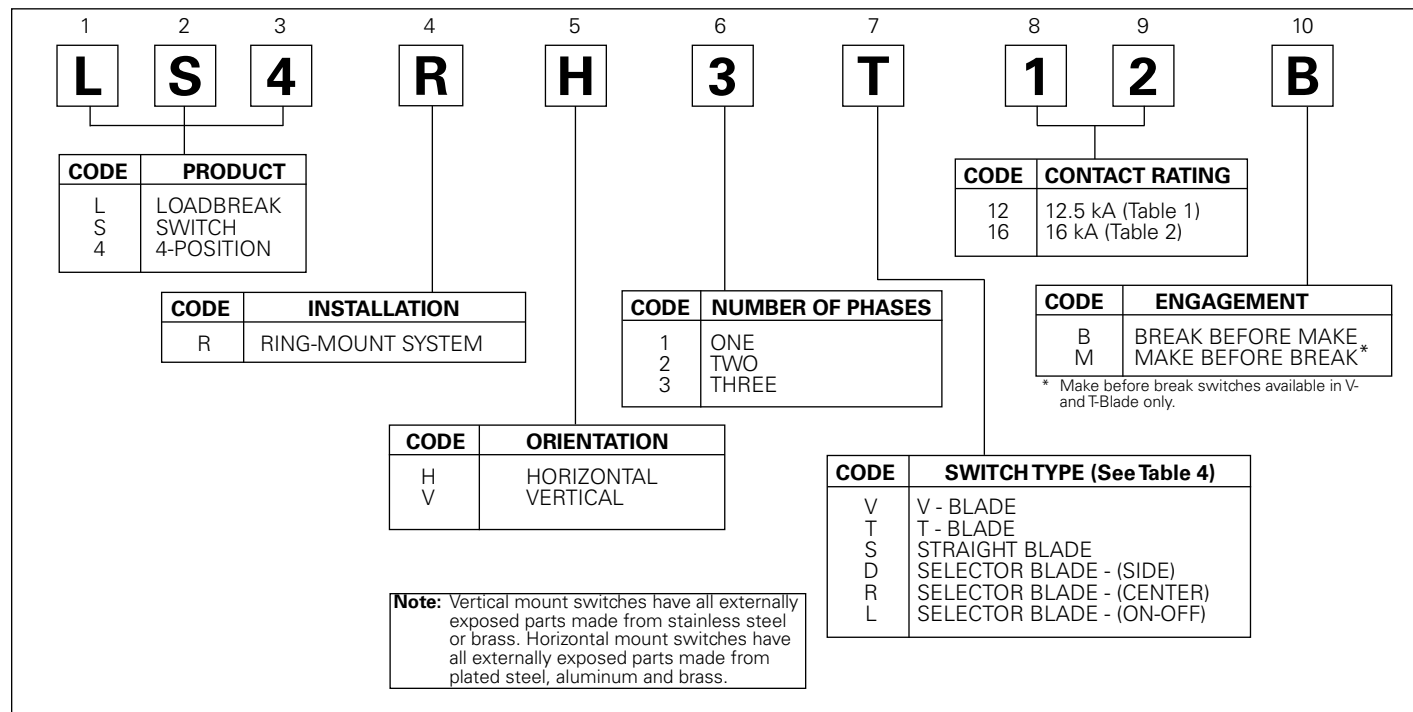

**Table 6. Accessory Parts**

Description	Catalog Number	Drawing
Conversion Mounting Bracket* for Ring-Mount system. Includes hole and pins per Figure 5	2037424C04M	4200738N
Pad-lockable Handle** per Figure 6 Aluminum	2239000B14	4201093N
Clampstick Leverage Tool***	CS125UFLT00L	-

\* Bracket is mild steel, 6" x 6" x 0.134" (152 mm x 152 mm x 3.4 mm).

\*\* Pad-lockable handle must be ordered separately.

\*\*\* Recommended for usage with Fit-On™ end clampstick to provide operator with an increased level of mechanical advantage when performing switching operations.)

### Additional information

Refer to the following reference literature for application recommendations:

MN800002EN, Sectionalizing Switch Installation Instructions

CP0316, Certified Test Report: 12 kA Four-Position Sectionalizing Loadbreak Switch

CP0313, Certified Test Report: 16 kA Four-Position Sectionalizing Loadbreak Switch

**Eaton**  
 1000 Eaton Boulevard  
 Cleveland, OH 44122  
 United States  
 Eaton.com

**Eaton's Cooper Power Systems Division**  
 2300 Badger Drive  
 Waukesha, WI 53188  
 United States  
 Eaton.com/cooperpowerseries

© 2015 Eaton  
 All Rights Reserved  
 Printed in USA  
 Publication No. CA800005EN

Eaton, Cooper Power, and Fit-On are valuable trademarks of Eaton in the U.S. and other countries. You are not permitted to use these trademarks without the prior written consent of Eaton.

IEEE Std C37.71™-2001 standard is a trademark of the Institute of Electrical and Electronics Engineers, Inc., (IEEE). This publication is not endorsed or approved by the IEEE.

IEEE® is a registered trademark of the Institute of Electrical and Electronics Engineers, Inc.  
 Envirotemp™ and FR3™ are licensed trademarks of Cargill, Incorporated.

For Eaton's Cooper Power series loadbreak switch product information call 1-877-277-4636 or visit: [www.eaton.com/cooperpowerseries](http://www.eaton.com/cooperpowerseries).